

Automated Robotic Assembly Cell

In sponsorship with
ThyssenKrupp Bilstein of America, Inc.

A Baccalaureate thesis submitted to the
Department of Mechanical and Materials Engineering
College of Engineering and Applied Science
University of Cincinnati

in partial fulfillment of the
requirements for the degree of

Bachelor of Science

in Mechanical Engineering Technology

by

Alex M. Hoffman

April 2020

Thesis Advisor:

Professor Moise Cummings

TABLE OF CONTENTS

TABLE OF CONTENTS..... 1

LIST OF FIGURES 2

LIST OF TABLES 2

ABSTRACT..... 3

PROBLEM DEFINITION AND RESEARCH 4

 PROBLEM STATEMENT4

 BACKGROUND.....4

RESEARCH..... 5

 SCOPE OF THE PROBLEM.....5

 CURRENT STATE OF THE ART5

 END USER.....6

 CONCLUSIONS AND SUMMARY OF RESEARCH.....6

CUSTOMER FEATURES 7

PRODUCT OBJECTIVES 7

QUALITY FUNCTION DEPLOYMENT 8

DESIGN 9

 DESIGN ALTERNATIVES AND SELECTION9

 DESIGN ANALYSIS12

 LOADING CONDITIONS20

 SIMULATION.....21

 COMPONENT SELECTION22

PROJECT MANAGEMENT..... 24

 BUDGET, PROPOSED/ACTUAL.....24

 SCHEDULE, PROPOSED /ACTUAL24

 PLAN TO FINISH25

 SUSTAINABILITY AND MATERIAL USAGE.....25

WORKS CITED 26

APPENDIX A – HOUSE OF QUALITY..... 27

APPENDIX B – FABRICATION/TESTING PLAN..... 28

APPENDIX C 29

APPENDIX D..... 30

LIST OF FIGURES

Figure 1: Assembly Process Flow

Figure 2: Robot Selections

Figure 3: Robot Tooling Designs

Figure 4: IntelliFlex 240 Setup

Figure 5: Flange Assembly Station

Figure 6: 8mm Flange

Figure 7: 8mm Rubber Sleeve

Figure 8: 8mm Metal Collar

Figure 9: 10mm Flange

Figure 10: 10mm Rubber Sleeve

Figure 11: 10mm Metal Collar

Figure 12: Cell Cycle Time Analysis

Figure 13: Epson Vision System

LIST OF TABLES

Table 1: Weighted Customer Features

Table 2: Weighted Product Objectives

Table 3: Bill of Materials

Table 4: Budget Analysis

Table 5: Design I & II Schedule

Table 6: Design III Schedule

ABSTRACT

The following report outlines the detailed steps involved in designing a fully automated assembly cell that produces flange subassemblies using a multi-stage pick and place assembly process. Since this operation is currently being performed by hand using two operators, automating this assembly process will improve production rates and part consistency while reducing production cost. Major components of the assembly cell that were designed or selected include: two separate robotic technologies with custom tooling, high-tech part feeding and transfer mechanisms, and custom assembly and pack out station.

PROBLEM DEFINITION AND RESEARCH

PROBLEM STATEMENT

The purpose of this project is to automate a flange assembly operation to reduce non-value-added labor cost, improve ergonomics, and improve efficiency. This operation is a multi-stage pick and place assembly. First a metal sleeve is installed into a rubber seal. Then the seal assembly is installed into a flange. Finally, the flange assembly is packed out. An operator would stand in front of this manual station all day long repeating this operation. By automating this operation, the operator could bulk load incoming material, do more quality checks, and/or perform other operations within the cell.

BACKGROUND

The Industry 4.0 team at ThyssenKrupp Bilstein reached out to the University requesting for a group of seniors to take on an automation project to fulfill the requirements for senior design. The three-step flange assembly process that we are automating is currently being performed by hand using a single operator. This operator is responsible for inserting the steel sleeve into the rubber seal, assembling the seals into the flange, and placing the assembled flange into a storage tote. This method is simple and has been effective in the past, however by automating this assembly operation, the production efficiency and part consistency will increase while eliminating labor cost for a non-value-added operation.

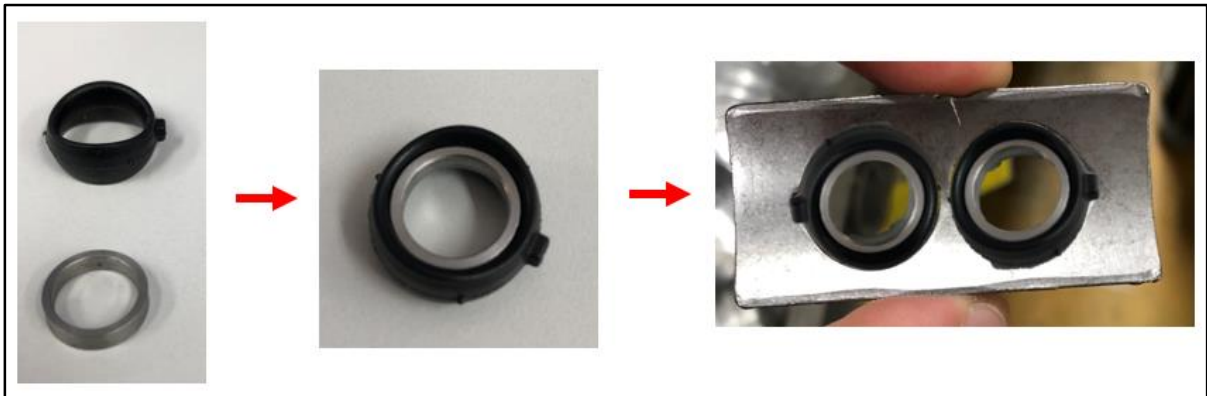

Figure 1: Assembly Process Flow

RESEARCH

SCOPE OF THE PROBLEM

The following research is focused on the part feeder selection and design, as well as overall design requirements to achieve full automation of the flange assembly process. Each flange consists of five total parts: one flange, two rubber seals, and two metal collars. Continuously presenting these parts to the robot in the same exact location and orientation has proven to be a tough challenge. Each flange has a top and bottom side that must be identified before the two seals are inserted, also the rubber seals have a small ridge that must be oriented towards the two ends of the flange.

CURRENT STATE OF THE ART

Businesses all across the country are switching to automated assemblies to save on labor and down time. There are an unlimited number of benefits to having a machine that can run 24/7 to supply a large volume of parts to its next operation. Currently, Bilstein is limited to as many assemblies of this part as one operator can create in a day. This bottlenecks the manufacturing process. By creating a way for these components to be autonomously assembled, we can eliminate this problem for Bilstein.

Due to the large volume of components and assemblies, we had to create a unique solution to presenting these seals to the assembly station. The clear choice was to implement and vibratory feeder. This type of feeder works well in this application because you can dump hundreds of components into one bowl, and it will bring them to the vibratory plate. This means very little operator time is required to keep stocking the cell up with components. The vibratory place will then shake the parts so they are not touching and laying in the correct orientation.

The metal flange is also possible to feed using a vibratory bowl feeder, but there are other devices to consider. A magazine style feeder mechanism would be another solution for staging the metal flanges that is low cost and easy to integrate, but it presents a challenge when loading a large number of flanges is necessary to keep operator input to a minimum. Both the vibratory bowl feeder and magazine feeder are potential options for this assembly system, but it will come down to storage capacity and efficiency to determine which method would work best for this application.

The Epson T3 SCARA industrial robot was gifted to our team, as it was left over from an existing automation project. This fit our needs perfect for rapid side to side movements once the rings are picked up. By pairing this with Epson's vision technology, we created a unique and incredibly efficient way of presenting the seals and sleeves to the assembly station.

END USER

Over the past two years, the Industry 4.0 team at Thyssen-Krupp Bilstein has been solving automation challenges within their manufacturing facilities using Cobots, or collaborative robots. Cobots are unique because they are safe to operate on a production floor without a surrounding safety cage, and they can easily be programmed to perform precise operations in less than one day. Collaborative robots are equipped with a fleet of sensors that will automatically slow down and stop the arm if anything were to impede its path, which includes misaligned or misfed parts that would otherwise be damaged by the robot tooling during retrieval processes.

Thyssen-Krupp Bilstein has tasked our team with designing and building an automated assembly cell using a collaborative robot from Universal Robots. This assembly process must deliver finished parts more efficiently and more consistently than the current assembly process that is being performed by a team of two operators. Also, an inspection camera will be mounted to the cobot to capture an image of each layer of parts to ensure part consistency and integrity. Along with eliminating non-value-added labor cost, automating this assembly process will increase product consistency, which is critical since this is part will join two additional parts during the following manufacturing process. In the end, the final assembly process will begin with an operator loading parts into a hopper and ends with the same operator removing a bin full of assembled parts. Additional requirements include meeting a cycle time for 15 seconds or less, total operator input must be less than two hours per eight-hour shift, production efficiency of 95% or greater, and the cell must be designed to run for 10 years at high volume (24/5).

CONCLUSIONS AND SUMMARY OF RESEARCH

In order to create and automated assembly cell, we need to ensure the safety of the operators, efficiency of the station, and the quality of each assembly. Safety will be monitored by installing a cage around the Epson SCARA, and efficiency will be observed with a Producibility study paired with a cycle time analysis. By implementing a method of inspecting parts for conformity, we anticipate beating not only our efficiency goal, but quality target as well.

By adjusting the speeds of the robots and rate at which components are fed, we can optimize the cycle time while maintaining a high level of part quality. Having a cell that can run autonomously will reduce the number of deviated parts as well as increase the volume of completed assemblies per day. This will eliminate the problem at hand of a choke point in their manufacturing process.

CUSTOMER FEATURES

After reviewing the overall project scope with the Industry 4.0 team we were able to identify seven main customer features: initial investment cost, efficiency, worker safety, ease of use, ease of maintenance, flexibility of use, and finished part consistency. ThyssenKrupp is responsible for the initial investment cost, and our team is responsible for meeting all customer features with a fully automated assembly cell design.

The production efficiency of the completed assembly cell must be greater than 95% and the cycle time for the assembly cell must be between 15-20 seconds. Worker safety is always the number one priority in any manufacturing environment, so it is critical that every decision is made with that in mind. Collaborative robots, like the once used in this assembly process, are special because they are safe to operate without guards and will stop immediately if their path is impeded.

The assembly cell will be designed to operate on its own, via automation, or by an operator in the case of equipment failure. The cell will also feature a 100%-part inspection system with a reject station to remove any parts that do not meet the quality standards outlined by ThyssenKrupp. With help from the Industry 4.0 team, we are well equipped to meet and exceed all the customer features necessary to make this project successful.

	Customer Features	Relative Weight
1	Initial Investment Cost	10%
2	Efficiency	25%
3	Worker Safety	25%
4	Ease of Use	10%
5	Ease of Maintenance	5%
6	Flexibility of Use	10%
7	Finished Part Consistency	15%

Table 1: Weighted Customer Features

PRODUCT OBJECTIVES

The product objectives are molded from the customer features. For the return on investment, we will reduce the amount of operator input from eight hours per shift, down to two. This will be done by designing our system to run independently for 6 hours of an 8-hour shift. Having separate feeders and the collaborative robot will significantly reduce the number of human hours needed at the machine, therefore improving efficiency. The efficiency of the machine will only be limited to the operator ensuring components are loaded. If the feeders stay fed, the cobot will not have any issues running without interruption.

In addition to this system being more efficient, it will be a more user-friendly process. Compared to assembling these components by hand, automating this operation allows the operator to tend to other tasks while the cell is running. When the operator is needed, their duties will be limited to keeping part feeders full and removing completed part containers. This will not only make their job easier but improve the safety of the system. The cobot is designed to stop immediately upon the arm bumping into any foreign object. For example, if the operator were to walk in the way of the cobot, it would lightly bump the operator before automatically shutting off. This is critical for the machine being on the shop floor.

We have designed the feeders so that they are highly accurate as well as repeatable. When talking maintenance, this is a must. Any automation system is subject to shut down for repairs or maintenance, however our system will have minimal down time. Simple bowl feeders will be implemented to ensure for a quick repair if it becomes jammed. This will in hand increase the consistency of the set up. With the parts being fed to the machine in the same orientation every time, we will see a much higher consistency at the assembly level. With consistency and ease of maintenance in mind, we also have designed the tracks to be interchangeable to accommodate for multiple component assemblies. Our quick attach tracks will be easy to swap out without severely interrupting manufacturing. All these customer features were in mind when designing the system to meet the product objectives.

	Product Objectives	Relative Weight
1	Production efficiency great than 95%	38%
2	15 second cycle time	26%
3	100% QA inspection	16%
4	Able to assemble two part variations	10%
5	1/4 of operator per 8-hour shift	8%
6	Run 24/5 for 10 years	3%

Table 2: Weighted Product Objectives

QUALITY FUNCTION DEPLOYMENT

In order to get feedback from our end users at ThyssenKrupp, we asked the Industry 4.0 team to distribute a customer survey to operators, supervisors, managers, and engineers that ranks each of our customer features based on importance. We also asked in the survey how many hours per week each responder spends working with automated assembly systems so that we can gauge the experience level of each response.

From the surveys we were able to determine that the most important customer feature when designing an automated assembly system is worker safety, which is always held in utmost importance in all manufacturing environments. Along with worker safety, part consistency and efficiency were among the most important customer features regarding automated assembly systems. Flexibility of use is also an important feature since the cell must be designed to run different part variations as well as running the cell with an operator rather than a robot.

DESIGN

DESIGN ALTERNATIVES AND SELECTION

Creating a fully functional automated assembly cell requires a variety of different components working in unison to complete an operation. This multi-stage pick-and-place operation requires major components such as two completely different robots with custom end-of arm tooling, a high-tech part feeding system, and custom designed assembly and pack-out stations.

Robot Selection

The first of the two robots used in the final design of the cell is the Epson T3 SCARA industrial robot. This robot was purchased for a similar automation project but was never used, so not only is this contribution an easy cost savings opportunity but it's also the exact robot needed for our application. SCARA robots are designed for high speed pick and place operations because of their ability to move parts quickly and accurately. With four degrees of freedom, the Epson T3 will be able to pick up, orient, and assemble all 3 parts with precision and within the cycle time requirements. One of the main advantages of using an Epson robot for flange assembly is the ability to integrate and part identification and feeding solutions using Epson RC+ software.

Once the flanges are assembled, they must be placed in small storage totes with plastic dividers separating each layer of parts. Responsible for this step in the operation is Universal Robot's UR5e collaborative robot, or Cobot. The ThyssenKrupp team at Bilstein has had great success using UR Cobots for machine tending, inspection, and assembly operations due to the unique capabilities of these robots. Cobots are the only industrial robots safe to operate without being enclosed by a safety barrier since they are equipped with pressure sensors that stop the robot in its path upon contact with any obstruction. Utilizing the six degrees of freedom, long reach, and universal tooling options of the UR5e, the Cobot will have no problems picking the finished flange assemblies, loading them into storage totes, placing a plastic divider between each layer of finished parts, and capturing images of the finished parts via mounted inspection camera.

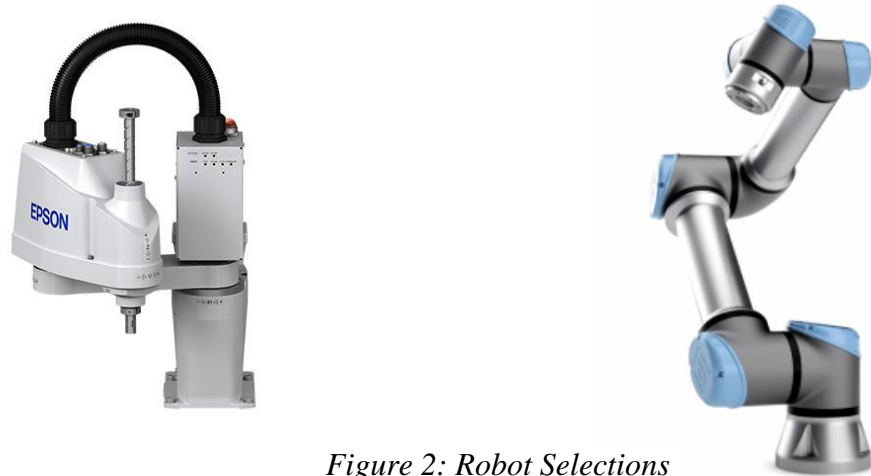

Figure 2: Robot Selections

End of Arm Tooling

Since two robots are being used in the cell, two sets of custom end-of-arm tooling are required in order to manipulate the parts within the cell at various steps of the process. For the SCARA robot, custom designed end effectors, or fingers, will be attached to a pneumatic parallel gripper that will control the movement of the fingers. The compact size and small stroke length of the Schunk PGN Plus P-64 universal gripper meets all the requirements for interacting with each of the parts and is compatible with the Epson T3. The fingers attached to the gripper will be machined from aluminum blanks purchased with the gripper from Schunk. These blanks are easily machinable and can be easily changed over for different part variations.

Tooling concepts for the UR5e changed multiple times over the course of the design process, and after receiving feedback on our application from design engineers at Bimba it was clear that we needed a custom solution. The team at Bimba was able to use our six-flange gripper design to create a fully functional dual head vacuum gripper. The primary gripper consists of a custom molded carbon fiber vacuum head used to pick up six flanges at time and place them in a tote for storage. The secondary gripper is a pair a suction cups that draw a vacuum to pick up and place dividers between each layer of parts. Also included in the UR5e tooling is a mount for an inspection camera that captures an image before placing a divider over a finished layer of assemblies.

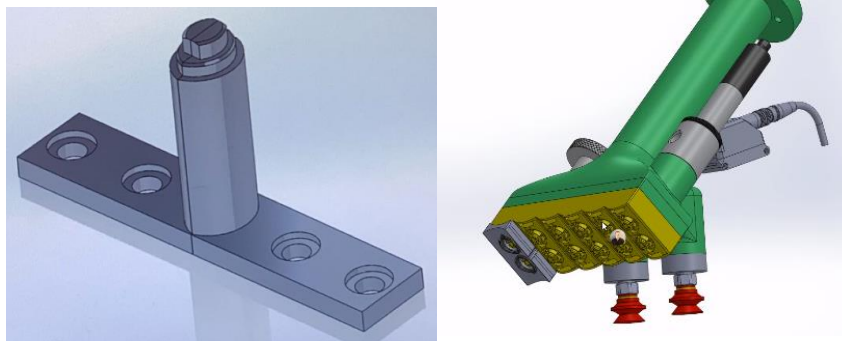

Figure 3: Robot Tooling Designs

Part Feeding Mechanisms

Designing a system to feed the three individual parts into the cell and present them in a way for the SCARA to assemble them proved to be a serious challenge. The flanges each have a small groove the backside that must be located for proper assembly, and the rubber seals have a small ridge to keep it in the flange that must be oriented in a specific direction. The most effective way orients the flanges and seals and have the SCARA identify each part is by integrating Epson's IntelliFlex parts feeding system into the cell. For our application, this system includes two IntelliFlex 240 feeders and three two-liter part feeding hoppers with controllers. The part feeding hoppers are designed to keep the flanges, rubber seals, and metal collars continuously fed into the IntelliFlex feeders. The IntelliFlex 240 feeders is a multi-axis vibratory bowl with backlit technology. Since these feeders work together with a vision system attached the Epson T3, we are able feed the rubber seals and metal collars into the same feeder and flanges into the second IntelliFlex. The integrated vision system on the T3 identifies part location and orientation and automatically selects parts in optimal locations.

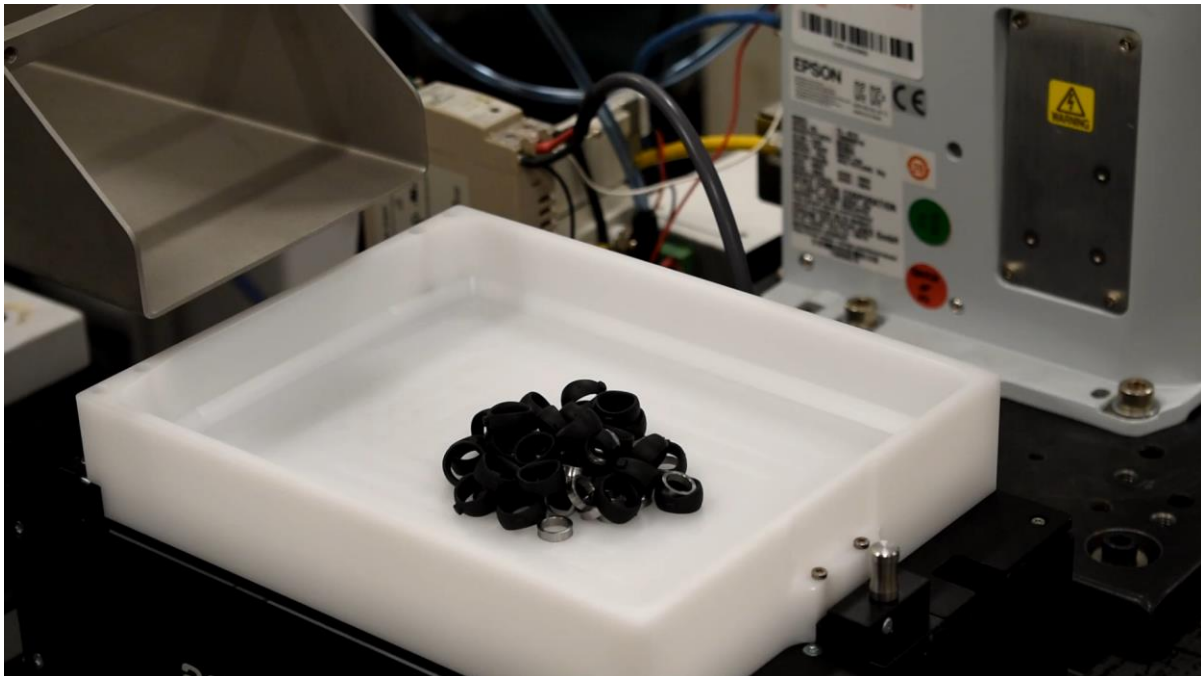

Figure 4: IntelliFlex 240 Setup

Assembly and Packout Stations

Our original concept for assembling the flanges was to use an indexing conveyor with custom molded fixtures designed to hold six assembled flanges. After further analysis, it was decided that an indexing conveyor is not suitable for robotic assembly because of challenges with repeatability and the low tolerances required for robotic assembly. The simplest, and

most effective solution for our time frame was to design and build our own custom fixture to locate flanges in an exact location assembly and transfer the finished parts to the pack out station. Using the same extruded aluminum material that the cell frame is built from, a design for an assembly fixture was created. By using a pneumatic gripper to hold the flanges in the exact location every time, the robot will be able to consistently place seals and collars into the flange. An air cylinder with a pusher moves the finished assemblies from the assembly station onto a miniature conveyor for transport to the pack out station. A second air cylinder pushes the finished assemblies into a staging area where the Cobot can pick six parts at a time to fill a row in the storage tote.

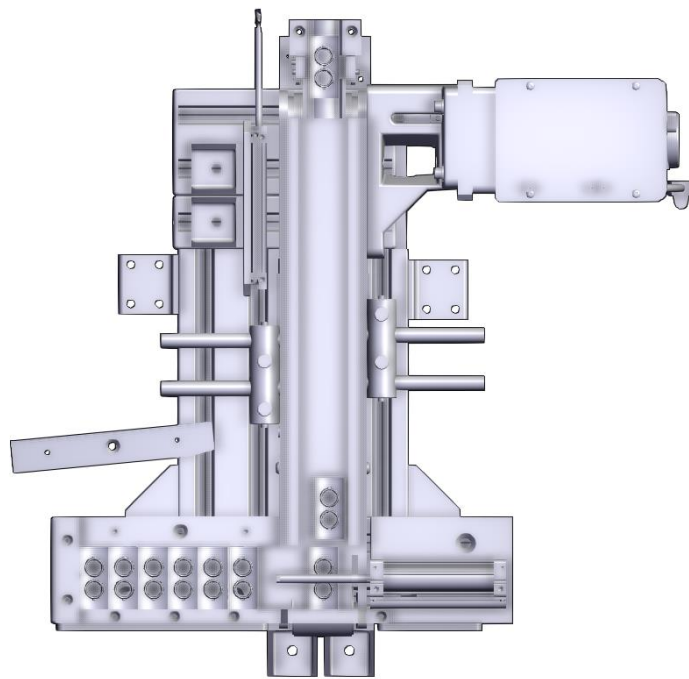

Figure 5: Flange Assembly Station

DESIGN ANALYSIS

Thyssen-Krupp provided our team with an existing automation cell structure and from there our team was tasked to develop a new automated system to complete the task of assembling small parts. An Epson T3 SCARA robot was also available to be reused from a previous Bilstein project. Starting with a base cell structure and the Epson T3, the design began to evolve and revolve around the space requirements and capabilities of the Epson T3. Using an online modeling software called Vention the frame structure was developed. Vention is an online modeling software build with a virtual library of parts built for designing automation structures. The program Vention allowed for multiple users to use and edit the same files

allowing the users to design in collaboration, thus making Vention a great tool within our design of the system.

The frame is designed to be used for both industrial and collaborative robots. The industrial parts of the frame are designed to completely enclose the Epson T3 with locked access door for maintenance. The collaborative design parts of the frame allow for the Cobot to be mounted externally with the proper proximity sensors for safety protocols. The design of the frame includes shelf on three sides of the frame for mounting the feeding hoppers and the pack-out station. After constructing a frame structure, we began to make selections of components for the systems to properly function. The Epson T3 robot is part of a line of similar automation products used for transferring, feeding, and assembling parts. The main operations of the system are to feed parts into the feeders, allow the system to recognize the parts, assemble the parts to form a product, and finally to unload the finished products. The system has three feeders used to load the parts into the system using one type of part per feeder. Upon parts being feed down into the Intelliflex Vibratory plates a vision tracking system will be used to sort the parts based of the orientation and type. Two Intelliflex Vibratory plates will be used within the system, allowing one for flanges and the other for metal sleeves and rubber gaskets. The Intelliflex feeders come equipped with three-liter hoppers for loading parts in bulk. The Epson T3 will be used for picking and placing parts from the feeders to the assembly station using end-of-arm tooling designed by our team. The part manipulator is being constructed of machined steel which is mounted to a SHUCK gripper used for opening and closing the part manipulator for picking and placing the parts. Precision is key for the Epson T3 to properly complete the task of picking, placing, and assembling the parts. Therefore, when mounting the gripper to the robot pilot holes will be used for alignment. Pilot holes will also be used when mounting the Epson T3 to the base tabletop.

A vision tracking system will then create an algorithm for picking up the parts depending the given positions in the most efficient manner. The Epson T3 will be given the algorithm from the visionary tracking system which instructs the robot to pick up parts and transfer the parts to the assembly station until the algorithm is complete then the cycle will repeat. The Epson T3 can pick up a metal sleeve and assemble the sleeve into a rubber gasket within the Intelliflex Vibratory plates then transfer the assembled part to the assembly station. The algorithm will instruct the robot to first pick up a flange and place into the assemble station. Then to pick up a metal sleeve and assemble the sleeve into a rubber gasket within the Intelliflex Vibratory plates then transfer the assembled part to the assembly station.

The assembly station is equipped with a conveyor belt, grippers and pushing blocks. Upon a flange being placed on the assembly station, the flange is placed on a gripper that is used to hold a flange in place while assembly. After the robot places the two assembled metal sleeves and rubber gaskets into the flange, the gripper will release the fully assembled flange allowing a mounted piston with a pushing block to push the finished flange onto a conveyor belt with guide rails. The assembled flange will be carried down to the final assembling stage and will be stacked in rows of six units. When the process is complete and six fully assembled flanges are stacked, the Cobot will maneuver its way into the system to pick up the group of finished flanges.

The Cobot is paired with a part manipulator designed by Bimba's engineering team using ideas from our concept designs. The end-of-arm tooling for the Cobot is a high suction vacuum gripper design with a custom 3-D printed carbon fiber insert used to pick up the entire group of six flanges at once. The section of the gripper that encounters the finished flanges has larger vent holes allowing more air to be sucked into the gripper which creates a suction effect against the finished flanges. Bimba's custom design of the Cobot gripper also includes two suction cups used for picking up the corrugated plastic dividers. The plastic dividers are placed in between the layers of finished goods. Once the six finished goods are stacked at the assembly station the Cobot is prompted to pick up the group of flanges. The Cobot is mounted directly above where the assembly station meets the pack-out station.

The pack-out station is equipped with a camera for product inspection and two totes used for loading the finished goods. The totes are positioned within the structure of the frame to guarantee them from moving while flanges are being loaded. The inspection camera will be mounted below the Cobot looking up at the custom Bimba tooling for the Cobot and will be used as the final line of inspection to guarantee all flanges are properly assembled. After picking up the finished flanges from the assembly station, the Cobot will place the row of six flanges into the tote. The totes are designed to fit six flanges across. This process will continue until a layer of flanges is completed in the tote. After each layer of finished flanges, the Cobot will pick up and place a piece of corrugated plastic over top of the finished layer of flanges. This process will continue until the totes are filled, then a Bilstein employee will unload the system of finished goods, replace empty totes, and replenish the raw materials for the cycle to continue.

By working closely with the Bilstein's Industry 4.0 design team, we can prove the efficiency and layout of the automated assembly cell to be enough by using simulations of the system. Being able to verify that the components will work in conjunction without interference and to test the cycle time of the system are all down using simulations. Due to the effects of COVID-19, our efforts of physically assembling the assembly cell and testing have been put on hold until further notice.

Drawings

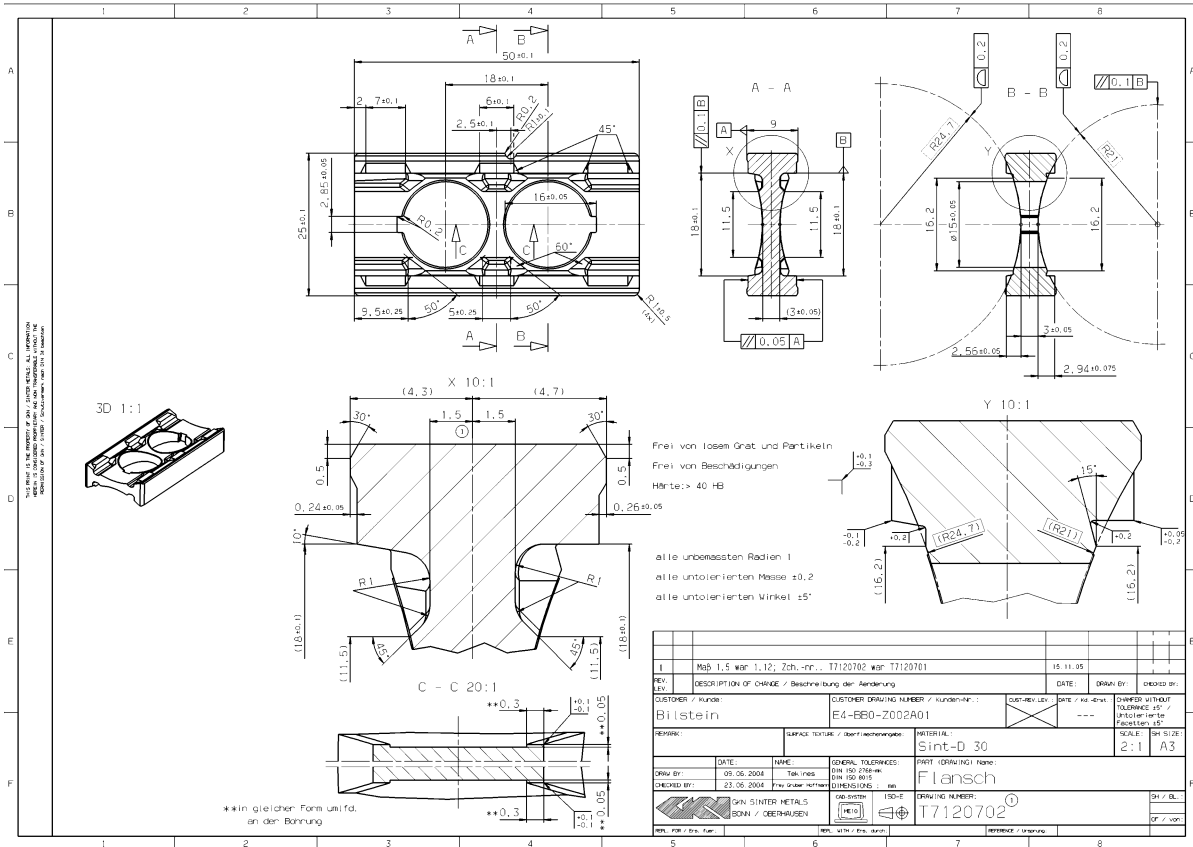

Figure 6: 8mm Flange

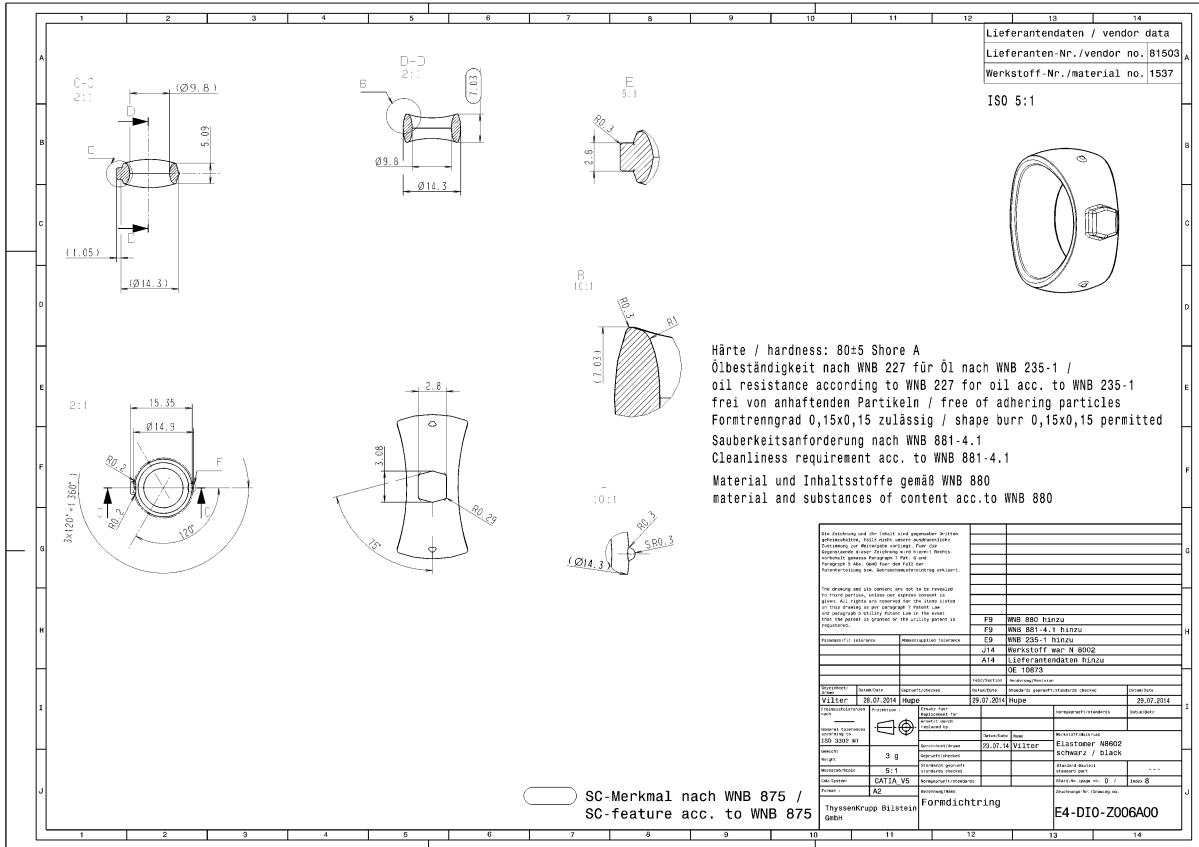

Figure 7: 8mm Rubber Sleeve

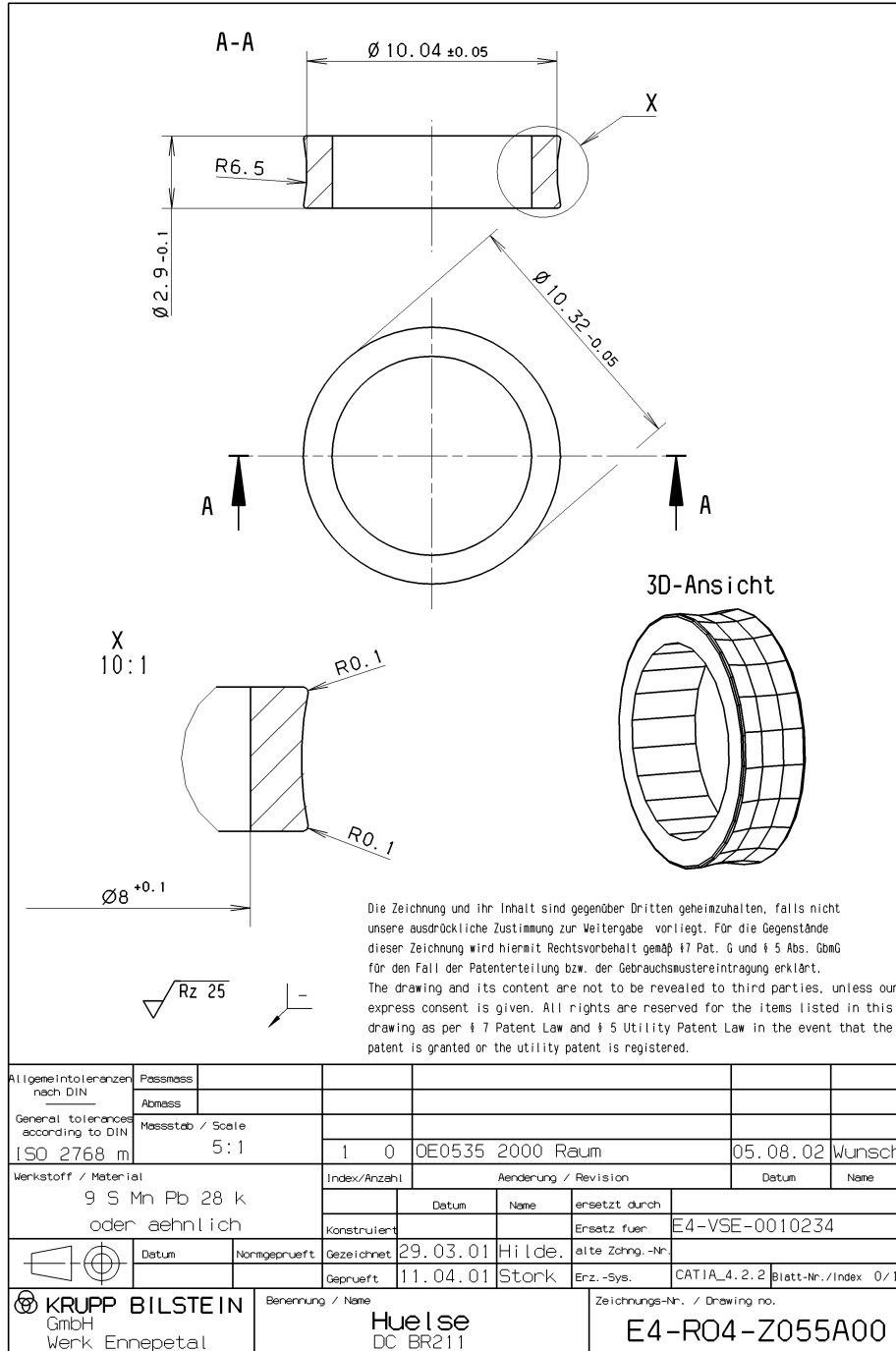

Figure 8: 8mm Metal Collar

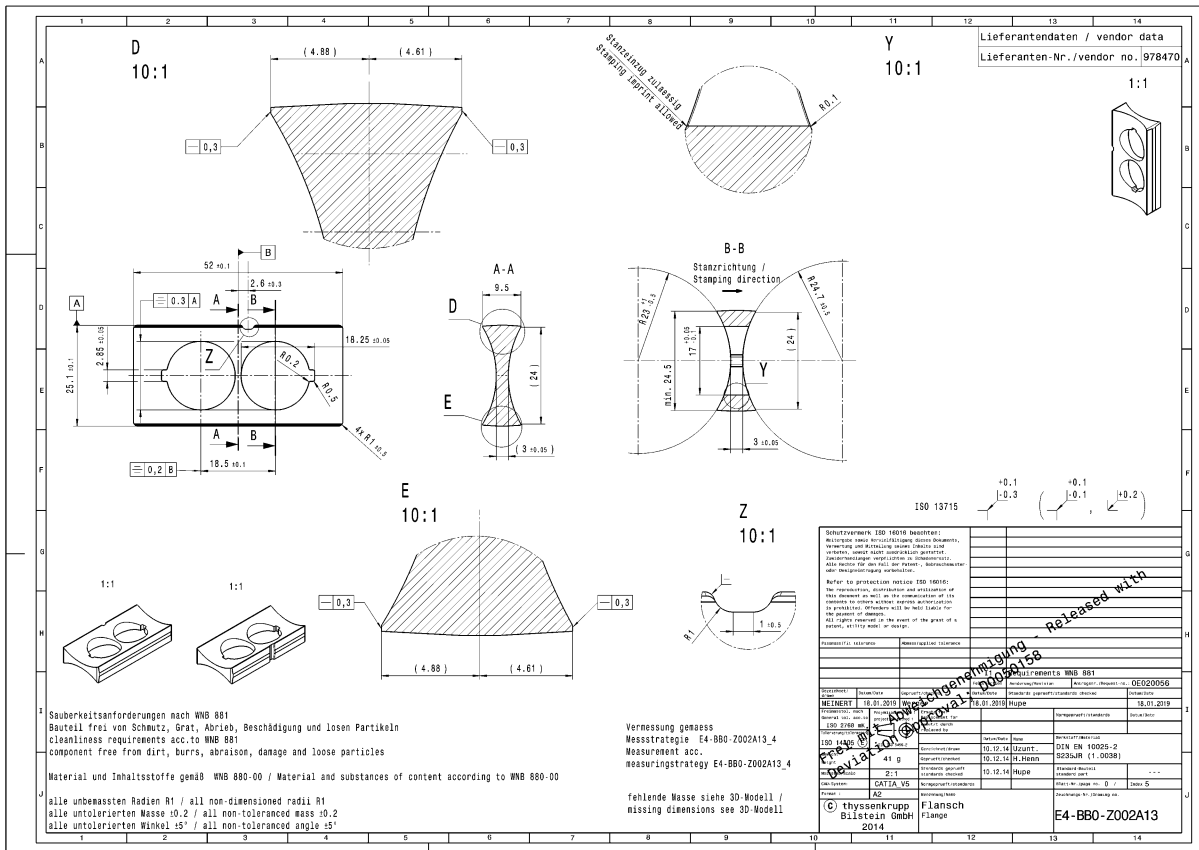

Figure 9: 10mm Flange

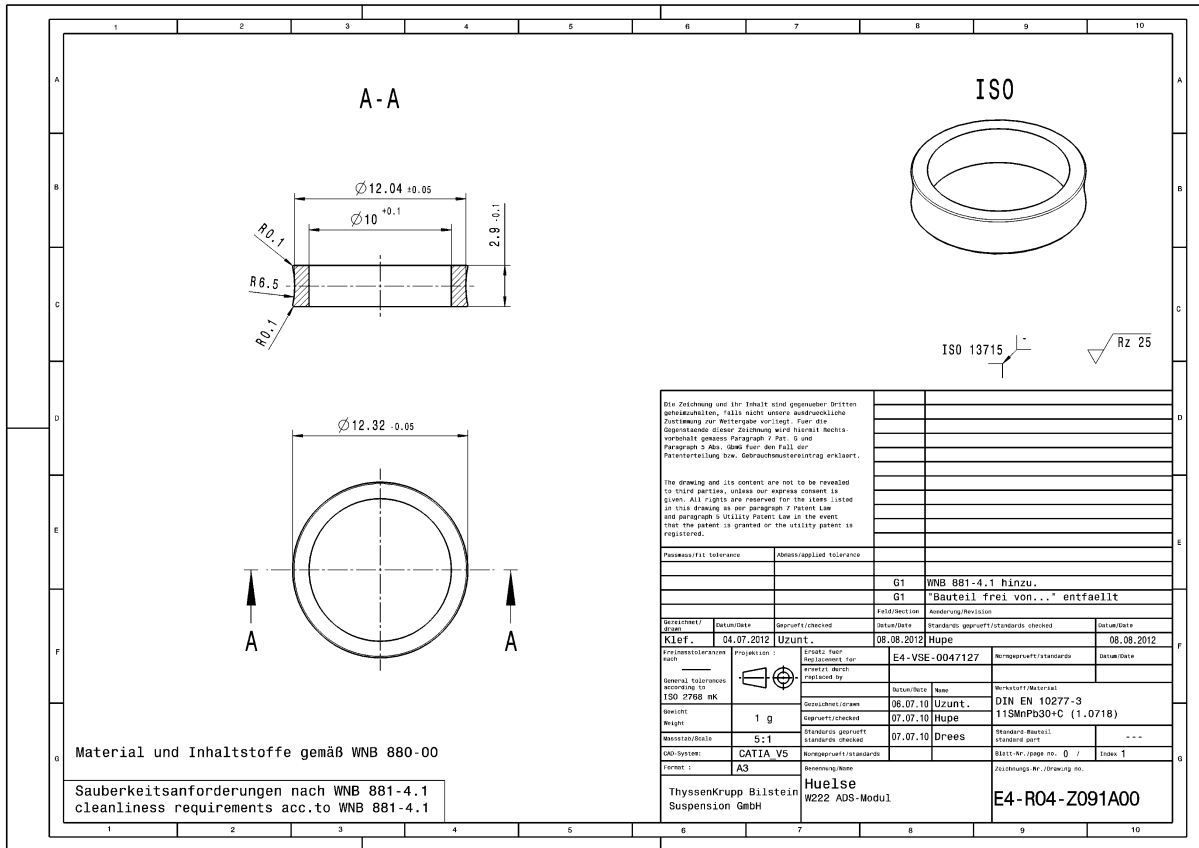

Figure 11: 10mm Metal Collar

LOADING CONDITIONS

The only loading conditions taken into consideration are for the main frame structure and the tabletop metal plate where the system is mounted. The aluminum extrusion framing is analyzed to confirm that the cobot can be safely mounted to the framing and be supported while in motion. The metal base plate is under review for being capable of holding the weight of the system being mounted upon the plate. Forces being applied to the structure from the system will rarely affect the structure during performance.

SIMULATION

Our target cycle time for the automated assembly station was 15 seconds. Once the model was completed, we could run a simulation and get an idea of how long it would take to assemble one flange. By timing how long it takes to make 150 assemblies, including pack out, we can confidently say our cycle time will be under 13 seconds. The exact time will vary depending on speeds and feeds of the robots, which will need to be dialed in to achieve the optimal quality to time ratio.

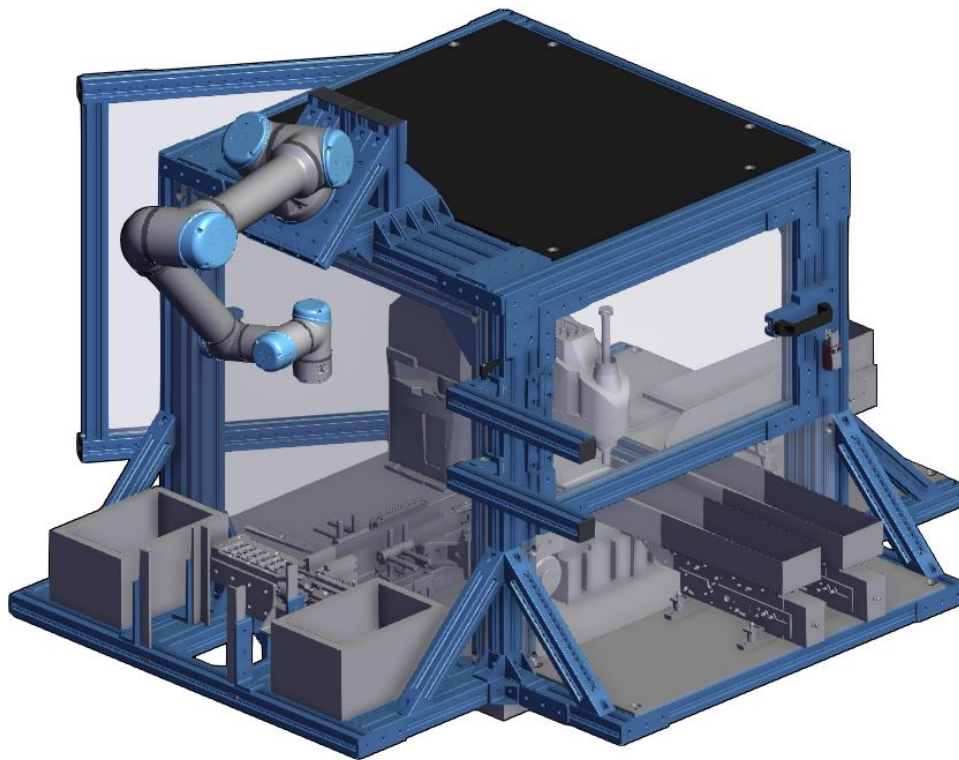

Figure 12: Cell Cycle Time Analysis

COMPONENT SELECTION

Epson has been known for its cutting edge technology for decades, and their vision system is no exception. Their vision camera in addition to the backlit tray allows for the recognition and location of either the rubber seal or metal collar. Using iterative alignment, it can grab the necessary component and bring it to the staging zone, where it can be pressed together. As shown in figure 13, when a component is too close to another or not in an ideal orientation for pickup, it will not accept it as a candidate for assembly. The ideal components get highlighted in green and their location is stored. Once it runs out of potential options for assembly, the feeder will either dump more components in, or the vibratory plate will disturb their orientation and attempt to make for a more ideal staging zone.

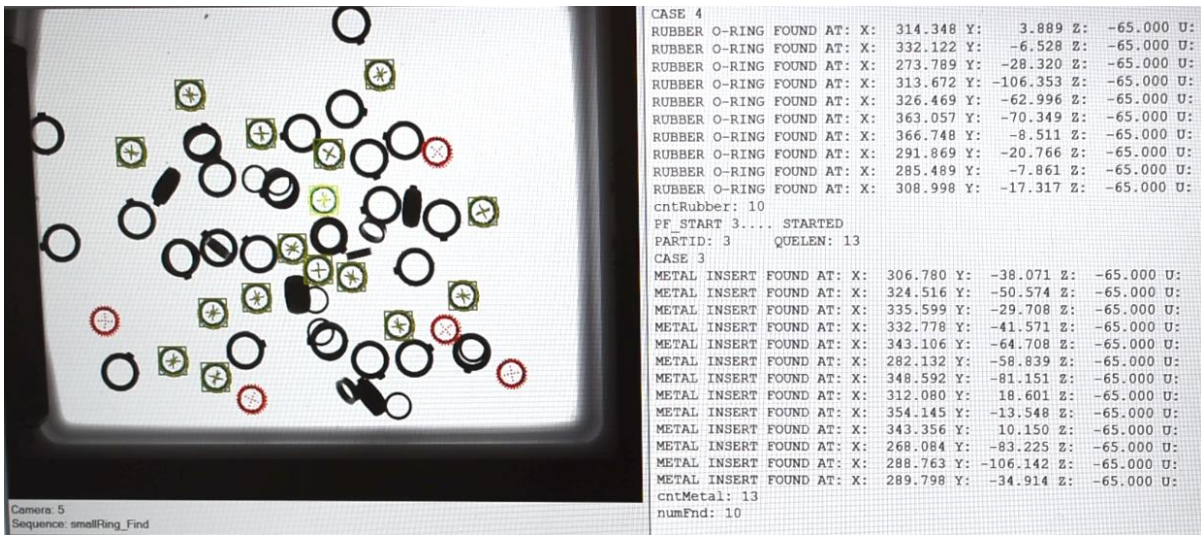

Figure 13: Epson Vision System

Bill of Materials	
Description of Major Components	Qty.
Existing Cell w/ miscellaneous components	1
Epson T3 All-in-one SCARA Robot	1
UR5e Collaborative Robot	1
Epson IntelliFlex 240 feeder	2
Epson Part Feeding Hopper	3
Epson Vision System	1
Schunk PGN Plus P-64 universal gripper	2
Festo Round Air Cylinder	2
QC Mini Conveyor	1
Bimba Dual Vacuum Gripper for UR5e	1
Custom Machined Tooling for Schunk Gripper	2
Keyence Inspection System	1
Vention Custom Cell frame w/ Cobot Mount	1
Allen Bradley PLC with HMI	1
Sensors and Safety Scanners	6

Table 3: Bill of Materials

PROJECT MANAGEMENT

BUDGET, PROPOSED/ACTUAL

Description	Proposed	Actual
Epson IntelliFlex Feeders	\$50,000	\$56,944
Epson T3 SCARA Robot	\$0	\$0
UR5e Collaborative Robot	\$30,000	\$30,000
Vention Extruded Aluminum Framing	\$4,000	\$5,580
End of Arm Tooling (Cobot & SCARA)	\$10,000	\$5,889
Steel Base w/ Casters and Electric Panel	\$0	\$0
Keyence Inspection System	\$5,000	\$2,790
Integration/Programming Labor	\$10,000	-
Miscellaneous	\$16,000	-
Total Budget	\$125,000	\$101,203

Table 4: Budget Analysis

SCHEDULE, PROPOSED /ACTUAL

Description	Design I & II Schedule	
	Proposed	Actual
Project Introduction from ThyssenKrupp	-	9/16/2019
First meeting w/ Industry 4.0 at Bilstein	9/18/2019	9/18/2019
Begin working on concept design	9/18/2019	9/19/2019
Final Proposal Due	10/4/2019	10/4/2019
Concept design Webex meeting	10/8/2019	10/8/2019
Meeting at Bilstein to approve major components	10/30/2019	10/30/2019
Webex meeting, for cell layout	11/15/2019	11/15/2019
Finalize cell design/layout	12/14/2019	2/27/2019

Table 5: Design I & II Schedule

Design III Schedule	Completion Date	
	Proposed	Actual
Description		
Finalize all major components for cell	1/27/2020	3/9/2020
Work with vendors to finalize component designs	2/3/2020	3/29/2020
Begin ordering components	2/10/2020	2/10/2020
Create testing plan with Bilstein	2/17/2020	2/17/2020
Order all remaining parts and components	2/24/2020	3/29/2020
Begin testing/ robot programming	3/2/2020	TBD
Cell testing and building	3/9/2020	TBD
Possible week of site visits @ Bilstein	3/16/2020	Cancelled
Complete testing, Finish building	3/23/2020	TBD
Prepare for Tech Expo	3/30/2020	Cancelled
Tech Expo	4/6/2020	Cancelled
Final Capstone Presentations	4/20/2020	4/20/2020
Final Report Submission	4/27/2020	4/27/2020
Final Exams	4/27/2020	4/27/2020

Table 6: Design III Schedule

PLAN TO FINISH

To finish the assembly cell, we need a few resources. First and foremost, we need personnel to help program the robots. Timing and synchronization is critical for this project, meaning we need to make sure everything moves where and when it is supposed to. Secondly, we will need help physically assembling the station. At this stage, we need time to repurpose the existing station that was given to us and make sure it can hold all the controls, electronics, and monitors necessary to make this cell functional. Once the materials arrive and the cell is assembled, then we will begin cycle time analysis and process prove out.

SUSTAINABILITY AND MATERIAL USAGE

Due to the longer than anticipated lead times for our custom components (Vention framing and end of robot tooling), we were not able to follow our original schedule. With the constant changing of design to meet new station criteria, we were forced into purchasing materials later than desired. In order to have met the original goal of having the station assembled and tested by the end of April, materials must have all been purchased months sooner. Although we missed this goal, our direct material usage was well planned. We had no excess material or unexpected expenses. In order to create a more sustainable project, we had to sacrifice our schedule. These decisions were made in junction with Bilstein to ensure quality of the cell.

WORKS CITED

1. **thyssenkrupp Bilstein Case Story.** *universal-robots.com*. [Online] Universal Robots, 2019. [Cited: September 19, 2019.] <https://www.universal-robots.com/case-stories/thyssenkrupp-bilstein/>.
2. **IDG Communications.** *What is RPA? : 2012*.
3. **IntelliFlex Parts Feeding System.** *epson.com*. [Online] Epson America, Inc., 2020. <https://epson.com/robots-intelliflex-parts-feeding>.

APPENDIX B – FABRICATION/TESTING PLAN

Fabrication/Testing Plan			
	Task	Description	Estimated Time Required
1	Install Vention Framing	Assemble and mount all framing and guards to existing cell	4 hours
2	Build and install assembly station	Assemble frame structure, mount conveyor, gripper, air cylinders and staging plate for FG	8-12 hours
3	Install base for SCARA	Mount raised platform to cell base and re install SCARA robot	2 hours
4	Install IntelliFlex feeding system	Mount all hoppers, controllers, and feeders	4 hours
5	Mount Cobot and install end of arm tooling	Mount the UR5e using the robot mounting plate from Vention, dual head gripper mount	2 hours
6	Assemble pack out station	Parts arrived with Vention framing, see drawings	1 hour
7	Test Feeding system, SCARA. & assembly station	Run the assembly program from Epson and debug as necessary, fine tune feeder and hopper settings	1-3 days
8	Test Cobot with dual head gripper	Run Cobot program for 6-8 hours continuously without failure	1-3 days
9	Comprehensive cell testing	Run cell from start to finish for an entire shift, meeting cycle time and production efficiency	3-5 days
10	Safety checks	Perform safety audit of cell, ensure functionality of all scanners, light bars, interlocks and other safety mechanisms	4 hours

APPENDIX C

APPENDIX D