

# Utility Terrain Vehicle (UTV)

A Baccalaureate thesis submitted to the  
Department of Mechanical and Materials Engineering  
College of Engineering and Applied Science  
University of Cincinnati

in partial fulfillment of the  
requirements for the degree of

Bachelor of Science

in Mechanical Engineering Technology

by

Brennen Birkemeier

April 2021

Thesis Advisor:

Professor Amir Salehpour

## Table of Contents

<b>Problem Statement</b> .....	5
<b>Research</b> .....	5
<b>Background of the Problem</b> .....	5
<b>End User</b> .....	8
<b>Summary of Research</b> .....	8
<b>Quality Function Deployment</b> .....	8
<b>Concepts Drawings</b> .....	13
<b>Calculations</b> .....	18
<b>Body Panels</b> .....	20
<b>Front Suspension and Steering</b> .....	21
<b>Project Management</b> .....	22
<b>References</b> .....	24

## **List of Figures**

Figure 1: shows a standard drum brake assembly with its components .....	6
Figure 2: shows a disc braking system along with its components.....	7
Figure 3: shows a servo braking system along with its components .....	7
Figure 4: Shows concept 1 design .....	13
Figure 5: shows concept 2 design.....	14
Figure 6: shows concept 3 design.....	15
Figure 7: shows the completed braking system design .....	16
Figure 8: shows the Willwood brake caliper chosen .....	17
Figure 9: shows the Willwood master cylinder chosen .....	17
Figure 10: shows the Willwood brake disc chosen .....	17
Figure 11: shows the Willwood brake pad chosen .....	17
Figure 12: shows the completed body panel assembly drawing .....	20
Figure 13: shows the completed front suspension and steering assembly .....	21

## **Abstract**

The concept of an all terrain vehicle (ATV) has been around for decades, more so the concept of a utility terrain vehicle. Combining the agility and speed of an ATV with the ability to haul tools and trailers creates a multipurpose vehicle that anyone is sure to enjoy. Being that today's market of utility terrain vehicles are very expensive, our professor had challenged us to create a simpler, less costly version of a utility terrain vehicle for his personal use. Myself and 2 team mates split this project up into three categories. They being 1.) frame, 2.) body panels, brakes, and 3.) drivetrain. Along with the overall design, assembly drawings as well as individual part drawings and purchased components were compiled onto a flash drive for next year's team.

## **Problem Statement**

For our senior design project, we will be completing the design and fabricating a UTV. The aim is to improve upon and/or redesign the current braking system, drive train, and suspension in an affordable, easily adjustable, and maintainable way

## **Research**

### **Background of the Problem**

Many improvements can be made to the modern utility terrain vehicle. We chose to narrow our approach to three main components within the typical UTV: the braking, drive train, and suspension. More specifically, we would like to focus on maintenance and adjustability of each of the three components mentioned above. We aim to make an affordable and simplistic product, perhaps even allowing the operator to adjust “on the fly” without taking their UTV to a mechanic.

Anyone who owns or operates a UTV on a regular basis is impacted by this problem. Mainly, our target audience would be individual users with a more adventurous or on the go lifestyle which might require a quick change or adjustment of suspension or drivetrain parts. In addition, anyone with limited free time who would like to spend it using their UTV instead of taking hours to adjust for different terrain and conditions.

Anybody who has gone for a joyride in any vehicle knows that there is no problem worse than getting ready to go and having to fix an issue with your vehicle. This issue only gets worse when you find the perfect spot to ride your UTV and find out that you need to adjust your suspension for the terrain. This results in a ride back home and a whole lot of disappointment for the user.

Currently, the maintenance options for a UTV come primarily from the manufacturer or aftermarket products which can cost the consumer a pretty penny. The closest quick fixes are very expensive and still require a handful of tools specifically designed for a single purpose (2).

We have identified a few areas where the current solutions are inadequate:

1. Convenience: The ability to adjust the suspension travel and overall height of the chassis relative to the wheels is selectively available, however none of the solutions allow for adjustment without a separate tool. This is one feature which we hope to add to our UTV.
2. Speed: Many current methods of adjustment and maintenance require the consumer to set aside an entire day. We hope to make our maintenance as fast and accessible as possible.

## State of the Art: Braking Systems

The portion of the UTV that I was mainly tasked with was the braking system as well as body panels. To start of my research, I began by looking into the different types of braking systems. Not only did I look into systems commonly used in UTVs today, which are most generally disc brakes, but also systems that are used in other applications. In doing this, I was able to put some ideas together on how to combine different braking systems to create a more convenient system for the user in terms of maintenance and usability. Some examples of braking systems I researched are drum brakes, disc brakes, hydraulic brakes, electromagnetic brakes, and servo brakes.

The first braking system I researched was drum brakes. When I think of the first type of braking system, I think drum brakes. However, it is not well known that disc brakes were patented by Frederick William Lanchester in 1902, the same year Louis Renault patented drum brakes. Although disc brakes were a superior design, it would take half a century before the technology could successfully manufacture the necessary parts. (A) Drum brakes work on a fairly simple concept. There is an outer casing, or drum, that is attached to the wheel hub and rotates with the wheel. Inside this drum, there are 2 “shoes” that are actuated by a hydraulic cylinder. When the brake pedal is compressed, hydraulic fluid fills the cylinder and expands the shoes inside out until they reach the inner wall of the drum. The vehicle kinetic energy is then turned into heat energy (friction), slowing the vehicle down. Drum brakes have many advantages but can also pose disadvantages depending on their application. Some advantages include an increased braking force than an equal diameter disc brake, last longer due to an increase contact surface, cheaper to manufacture than disc brakes, lower heat generation on rear axle, require less input force for desire output force,, protection from loose debris, and have slightly lower frequency maintenance due to low corrosion and wear. (B) The disadvantages of drum brakes include higher heat generation when braking is heavy, thermal expansion on hard braking can require more input force by the operator, brake fluid vaporization, their complexity, and their increased maintenance time compared to their counter part that is disc brakes.(B)

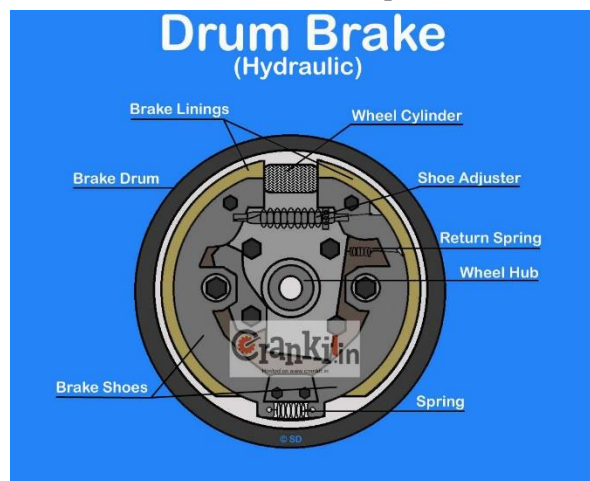

Figure 1: shows a standard drum brake assembly with its components

The next braking system I researched was disc brakes. Similar to drum brakes, disc brakes also use a metal on metal concept to create friction to slow the vehicle. Disc brakes have 3 main components. These are the rotors, the caliper, and the brake pads. The rotor is a large round metal disc that rotates with respect to the axle. The caliper acts as a housing piece for the brake pads. Much like the shoes of drum brakes, the brake pads in disc brakes are what contact the rotor and create the friction to slow the vehicle. Disc brakes use an inward motion to contact the rotor, whereas drum brakes use an outward motion to contact the drum. Advantages of disc brakes include an increased dissipation of heat due to the contact surface of the rotor being partially exposed to air at all times, fast performance time when wet due to rain or driving in water, self-adjustment eliminates the need for frequent brake calibrations, and are generally

easier to service than drum brakes.(C) There are disadvantages, however. Some of these disadvantages include an increased chance of loud and squeaky brakes, they require higher braking forces by the operator, and the rotors are more prone to warping if heavy braking is done. The slightest of warping can lead to pulsations and shaking which can only be fixed by resurfacing of the rotors or complete replacement of the rotors.(C)

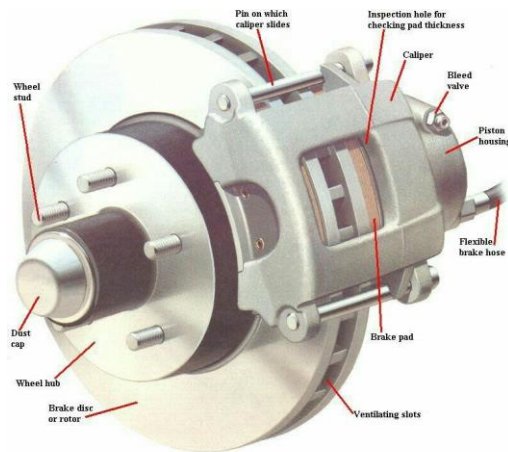

Figure 2: shows a disc braking system along with its components

The last braking system I chose to research is a servo braking system. I had no idea what this was initially, but upon research, I found it is quite popular and common in many everyday vehicles. A servo braking system for a gasoline engine is located somewhere between the brake pedal and the main braking cylinder and most generally utilizes a vacuum concept. The servo system has a large diaphragm that, when the engine is running, uses the engines air intake to create a vacuum inside. (D) Basically, once the vacuum is created, it is held until the user pushes the brake. The internal vacuum allows the user to put less work into the pedal, and have more work come out of the pedal. In a way, it assists the operator in a way much like power steering does. It just makes operation easier. The only disadvantage I can see with servo braking systems is the maintenance difficulties.

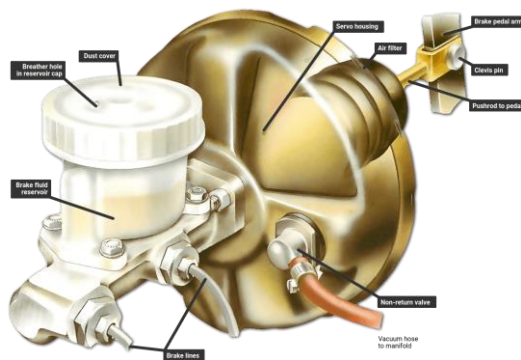

Figure 3: shows a servo braking system along with its components

## **State of the Art: Body Panels**

I was not able to find any specific examples or pros and cons of certain types of sheeting. I have broken it down into what I have seen the most. These being Stainless Steel, Aluminum, and Polyethylene. Anymore, Stainless Steel and Aluminum have been nearly obsolete in the UTV industry. With the elongation at break percentage of Stainless Steel and Aluminum being 70% and 12%, respectively, Polyethylene has an elongation percentage anywhere from 400% to 600%. (e) Not only this, but the cost of these materials at a thickness of 1/4" and a size of 4' by 8' is \$964.16 for Stainless Steel, \$758.40 for Aluminum, and an incredible \$86.40 for Polyethylene. Looking at any company that makes UTVs, they are using Polyethylene body panels and rightfully so. They are saving an amazing amount of money and the structural integrity is still great enough to withstand and bounce back from great impacts. Another great thing about Polyethylene body panels, is the ease of replacing them. If one, by chance, does break or crack, replacements are very easy to order on OEM websites and can be installed by the average operator.

## **End User**

The ideal end user will be 20 to 60 years of age. They will have a medium income. Male or female and able bodied. Some minor mechanical knowledge will be required, but no more than the average individual who changes the oil on their car. The finished product will not accommodate any specific medical disabilities and will be ergonomically suited for a person in the specified age group.

## **Summary of Research**

Upon finishing all my research, and gathering all notable information, I have definitely improved my understanding of the component make up and function process of the three braking systems chosen. All braking systems are in their own way useful to the application of UTVs, however, some stand out more than others when their disadvantages come into play. Based off what I have gathered, I feel the industry would highly benefit from a braking system that combines the protection and durability of drum breaks, the simplistic and open concept of disc brakes, as well as the ease of use with the assistance of a servo brake.

## **Quality Function Deployment**

### **Customer Features**

Between the 3 people working on this project, a total of 45 people were surveyed. The first survey question asked for the survey taker's perceived mechanical aptitude, allowing us to weigh responses of engineers and mechanics slightly higher. Following this question, they were asked if they had ever owned a UTV. These two questions allowed us to calculate our weighted score. We chose to weigh anyone who rated their mechanical aptitude higher than a 3 as 1.25, while responses below were weighed as 1. The rest of the survey asked the survey taker to rate the importance of customer features. After averaging the answers together and rounding to the nearest decimal, the table below was created.

Customer Features	Weighted Score
1.) Maintenance	4.1
2.) Safety	4.3
3.) Braking	3.5
4.) Cargo Capacity	3.7
5.) Transmission	3.6
6.) Steering	3.1
7.) Suspension	3.9
8.) Investment Cost	4.3

## **Engineering Characteristics**

Through further discussion and after a review of our survey responses, the group had to narrow down exactly how to describe the customer features in terms of measurable benchmarks, and units to describe these benchmarks. This led to the following list of engineering characteristics.

- 1.) Material Strength (psi)
- 2.) Storage Space (cubic inches)
- 3.) Suspension Travel (inches)
- 4.) Brake Clamping Force (psi)
- 5.) Steering Wheel Turning Torque (ft.lb)
- 6.) Torque at Wheels (ft.lb)
- 7.) Life of product (yrs)
- 8.) Overall Cost (\$)



Row #	Max Relationship Value in Row	Relative Weight	Weight / Importance	Danded Quality (a.k.a. "Customer Requirements" or "Whats")	Quality Characteristics (a.k.a. "Functional Requirements" or "Hows")	Column #	1	2	3	4	5	6	7	8
						Direction of Improvement: Minimize (▼), Maximize (▲), or Target (X)	X	▲	▲	X	▼	X	▲	X
1	9	13.4	4.1	Maintenance	Material strength (psi)		▲						⊙	▲
2	9	14.1	4.3	Safety	Storage Space (cubic inches)	⊙				⊙	▲		⊙	⊙
3	9	11.5	3.5	Braking	Suspension Travel (inches)					⊙				
4	9	12.1	3.7	Cargo Capacity	Brake Clamping Force (psi)			⊙						
5	9	11.8	3.6	Transmission	Steering/Wheel Turning Torque (ft.lb)						▲			
6	9	10.2	3.1	Steering	Torque at Wheels (ft.lb)							⊙		⊙
7	9	12.8	3.9	Suspension	Life of Product (yrs)	▲	⊙	⊙			▲	⊙		
8	9	14.1	4.3	Investment Cost	Overall Cost (\$)	▲							▲	⊙
9														
10														

<b>Target or Limit Value</b>	36,000	7	10	680	2	45	8	15,000
<b>Difficulty</b> (0=Easy to Accomplish, 10=Extremely Difficult)	1	2	2	5	4	3	5	8
<b>Max Relationship Value in Column</b>	9	9	9	9	9	9	9	9
<b>Weight / Importance</b>	167.2	147.5	161.6	176.1	130.5	175.1	177.4	218.0
<b>Relative Weight</b>	12.4	10.9	11.9	13.0	9.6	12.9	13.1	16.1

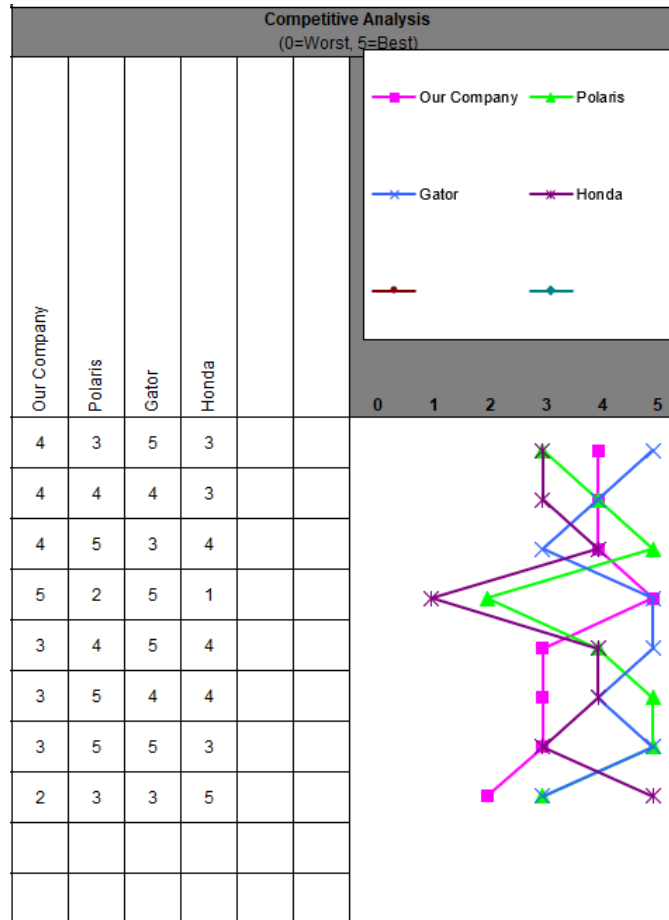

## Product Objectives

Based on our House of Quality the engineering characteristics are listed below in order of importance, with the first on the list being most important

- 1.) Overall Cost (16.1%)
- 2.) Life of Product (13.1%)
- 3.) Brake Clamping Force (13.0%)
- 4.) Torque at Wheels (12.9%)
- 5.) Material Strength (12.4%)
- 6.) Suspension Travel (11.9%)
- 7.) Storage Space (10.9%)
- 8.) Steering Wheel Turning Torque (9.6%)

Our group has certainly set some ambitious goals, but there is no doubt in our mind that we will be able to at the very least achieve these goals, with the target being to exceed them in the design of our UTV.

## **Concepts Drawings**

As a group, when it comes to the actual research and design portion of this UTV, we have been sort of tossed into the fire due to the fact that our project has already been started. I ran into this contradicting problem when I was assigned the braking system for the UTV. From discussing with Professor Salehpour, and doing our own looking around, we learned that a good amount of parts had already been purchased for our UTV by the previous group it was assigned to. We discovered that the previous group had already decided on disk brakes for the UTV. In my research, I had found that disk brakes are the industry standard so that makes complete sense and I have no problems with it at all. The QFD showed that braking ability weighed in at a 3.5/5. I interpreted this as users think braking ability is important, but not necessarily the most important factor when they think of a UTV. In my research, I found that drum brakes have the ability to produce a greater braking force compared to disk brakes, but their bulkiness and complexity can cause issues for users down the road. With UTVs generally not being very heavy vehicles, I feel that the previous group made the same choice that I would have made in choosing disk brakes. This being said, I felt the best way for me to portray new concepts was to improve the protection factor of a disk brake system, as it is quite vulnerable and susceptible to debris and foreign objects. In my own personal experience, I have had situations where sticks, leaves, rocks, and so on, get caught in the brakes of my ATV, causing me to have to get off and resolve the problem. I brainstormed some possible ideas and below is what I came up with.

### **Concept 1:**

For my first design, I downloaded a STP file from a Subaru Brake System website to use as my base for all 3 design concepts regarding the protective shield. In this first design, I was mainly thinking about full coverage of the entire braking system. I basically designed an outer rim to protect not only the rotor, but the caliper and the brake pads as well. This shield would require the brake calipers to be modified with a matching hole pattern for the shield to mount to. I feel this design would serve as great protection for the braking system if the vehicle has very large tires that offset it from the ground. This would ensure that the bottom of the guard does not restrict travel across obstacles like fallen trees, holes, and rocks.

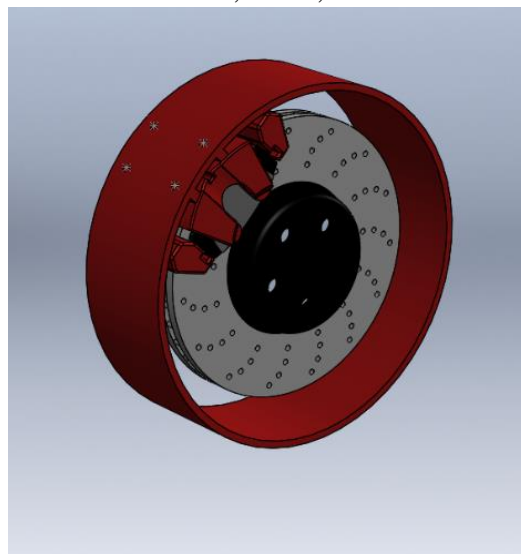

*Figure 4: Shows concept 1 design*

## Concept 2:

Concept 1 is a good design for a vehicle with large tires and I thought a similar design for any vehicle would be beneficial. This brought me to the idea of concept 2. It takes the same idea from concept 1, in that it mounts to the calipers (which would still need to be modified.) On further thinking, I realized that the most frequent time for debris to be a problem is when the vehicle is traveling forward, and at a high speed. This made me think that the 360-degree protection may not be necessary as you usually cannot reach very high speeds in reverse due to the engines governor. In redesigning, I chopped most of the rear section of the shield off, leaving the front of the rotor, the caliper, and the brake pads still protected from debris.

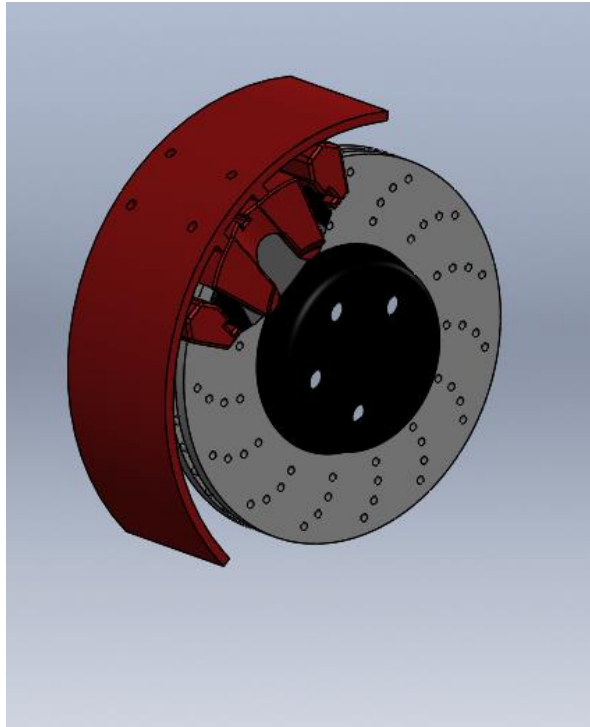

*Figure 5: shows concept 2 design*

### Concept 3:

Concept 3 came about because I looked at the fact that modifying something like a caliper on a braking system can not only be extraneous, but costly and also confusing for any mechanic or able-bodied owner to work with. I like the versatility of concept 2 and looked for a way to improve it. I started to think of existing products like mud flaps, that connect to the body of the vehicle and provide protection. This may make you think, “well why don’t you just use mud flaps then?” I believe it is very clear that a specifically designed shield will do the best job at providing full protection for the brake system. I took the mounting concept from mud flaps and applied it to my designed brake shields. Concept 3 can provide suitable protection for debris in the forward direction, as well as mitigate the need to modify any existing components.

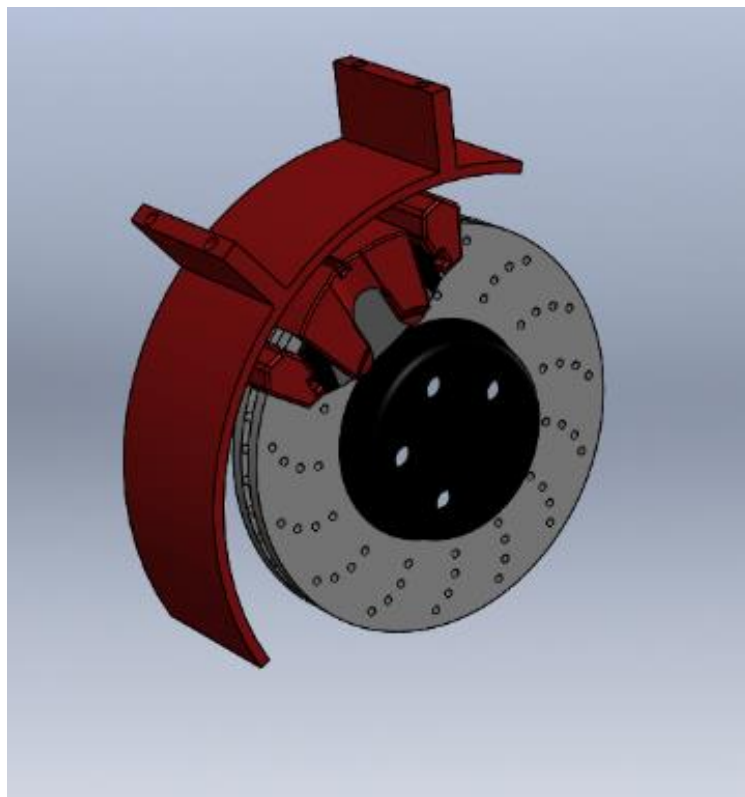

Figure 6: shows concept 3 design

## Final Design

### Braking System

The first step for coming up with a final braking system design was to lay out the assembly in a way that would work with the motor, transmission, and frame we already have. Once these were taken into consideration, a final design could be modeled based off calculations. The system we are using didn't have an available 3d model so I modeled a mock model myself. The complete braking system consists of a master cylinder, hydraulic brake lines, brake disc, brake calipers, and finally brake pads. I initially was going to mount the brakes on a separate plate right behind the motor, in which my protective design shown above would serve a great purpose in protecting the brakes from debris. However, based off the way our drivetrain was set up, I was forced to mount the braking system directly to the hub, much like that of a car. This being said, it worked out quite well since the wheel provides ample amounts of protection for the braking system. Below is the final braking system design as well as the components used for the braking system.

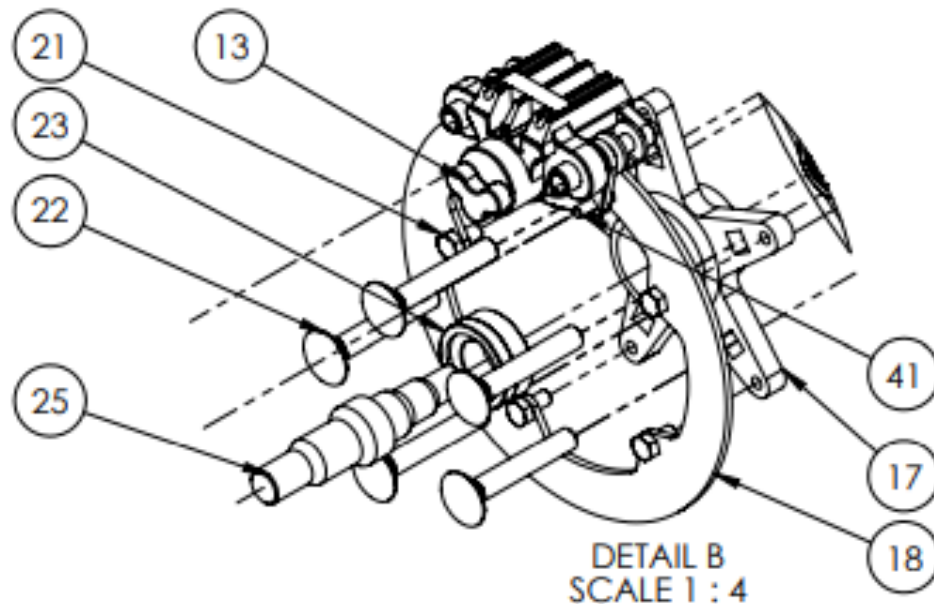

Figure 7: shows the completed braking system design



Figure 9: shows the Willwood master cylinder chosen



Figure 8: shows the Willwood brake caliper chosen



Figure 10: shows the Willwood brake disc chosen

Pad Plate: **6407**

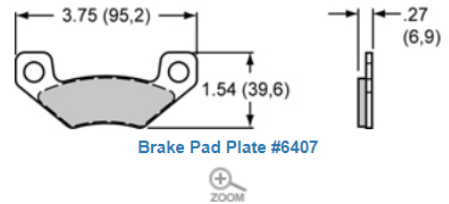

Figure 11: shows the Willwood brake pad chosen

## Calculations

The calculations needed for the braking system would ultimately put out a required braking force output from the braking system to stop the vehicle based off industry standard, being 40 feet stopping distance to go from 30mph to 0mph.

### **Given factors include:**

Vehicle weight = 680 lbs or 21.2lbm

Stopping distance = 40 ft

Starting speed = 30 mph

Coefficient of Friction for road and rubber = 0.7

I first calculated the kinetic energy that the vehicle would have at a speed of 30 mph. This calculation is below.

$$E_k = \frac{1}{2} * m * v^2$$

$$E_k = \frac{1}{2} * 21.2 \text{ lbm} * 30 \text{ mph}^2$$

$$E_k = 20,444.16 \text{ ft} - \text{lbs}$$

I then used this kinetic energy to calculate the overall force in the system.

$$F_V = \frac{E_k}{D}$$

$$F_V = \frac{20,444.16}{40}$$

$$F_V = 464.4 \text{ lbs}$$

Next, I used the coefficient of friction and the vehicles weight to find the force lost due to friction.

$$F_f = W * u$$

$$F_f = 170 \text{ lbs} * 0.7$$

$$F_f = 119 \text{ lbs}$$

With this information, I was able to find the total force that must be exerted by the brakes.

$$F_T = F_V - F_f$$

$$F_T = 345.64 \text{ lbs}$$

Having already selected the brake components, I now needed to verify that we could output this force. From research, I was able to find that the average human can press a brake pedal with 70 lbs of force. I first divided the required force by 2 due to the fact of two braking system working on the system. I then used a simple ratio to find the force output from the human input. Total output area was found by using the caliper bore diameter and the break pad surface area. Calculations are reflected below.

$$\frac{\text{Human Input Force}}{\text{Master Cylinder Area}} = \frac{\text{Total Braking Force}}{\text{Total Output Area}}$$

$$\frac{70 \text{ lbs}}{0.44 \text{ in}^2} = \frac{\text{Total Braking Force}}{2.93 \text{ in}^2}$$

$$\text{Total Braking Force} = 466.14 \text{ lbs}$$

I then determined that the output braking force of our system was substantially more than the required force, and that all the components selected would suffice.

## Body Panels

I ended up sticking with my original plan in that the body panels would be comprised of a mix between Lexan panels and 1020 hrs panels. The Lexan panels would make up any area of the vehicle that would encounter low amounts of stress and were least susceptible to hard debris like rocks and logs. The steel panels would make up any areas that would have a high chance of getting hit by a rock or log, as well as in front of and behind the driver to ensure safety from the engine as well as any front end components. Below is an assembly drawing of the panels and their locations.

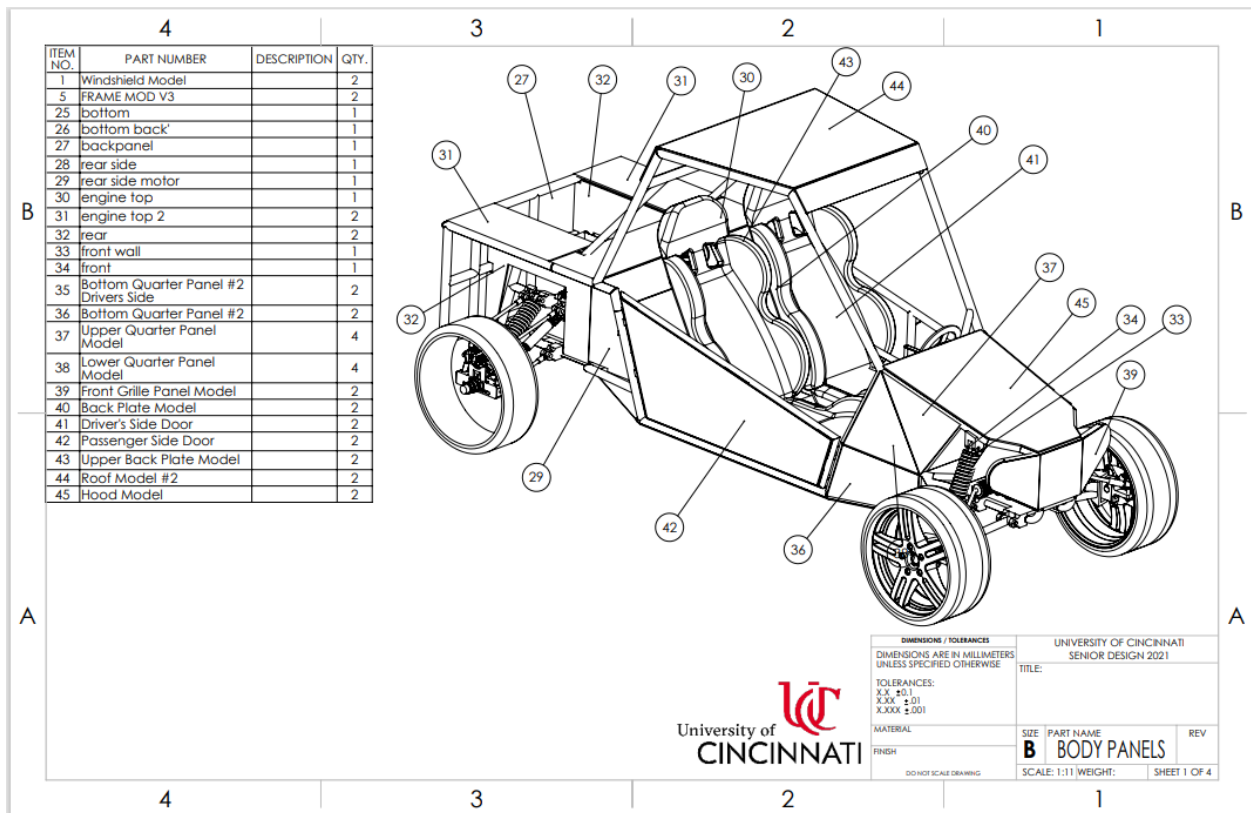

Figure 12: shows the completed body panel assembly drawing

## Front Suspension and Steering

With one of my group member initially taking the front suspension, we decided to split up the work evenly so he could have more time with the drive train. With him having the rear suspension complete, I derived much of my design off the rear end concept to keep uniformity. Each side of the front suspension is comprised of an A-frame style link arm, suspension shock, control arm, steering block, steering link, shaft, and lastly a hub. This assembly tied into the frame using linkage blocks and oil embedded thrust bearings and washers to ensure minimal friction and part wear. The assembly drawing of the front suspension and steering can be seen below.

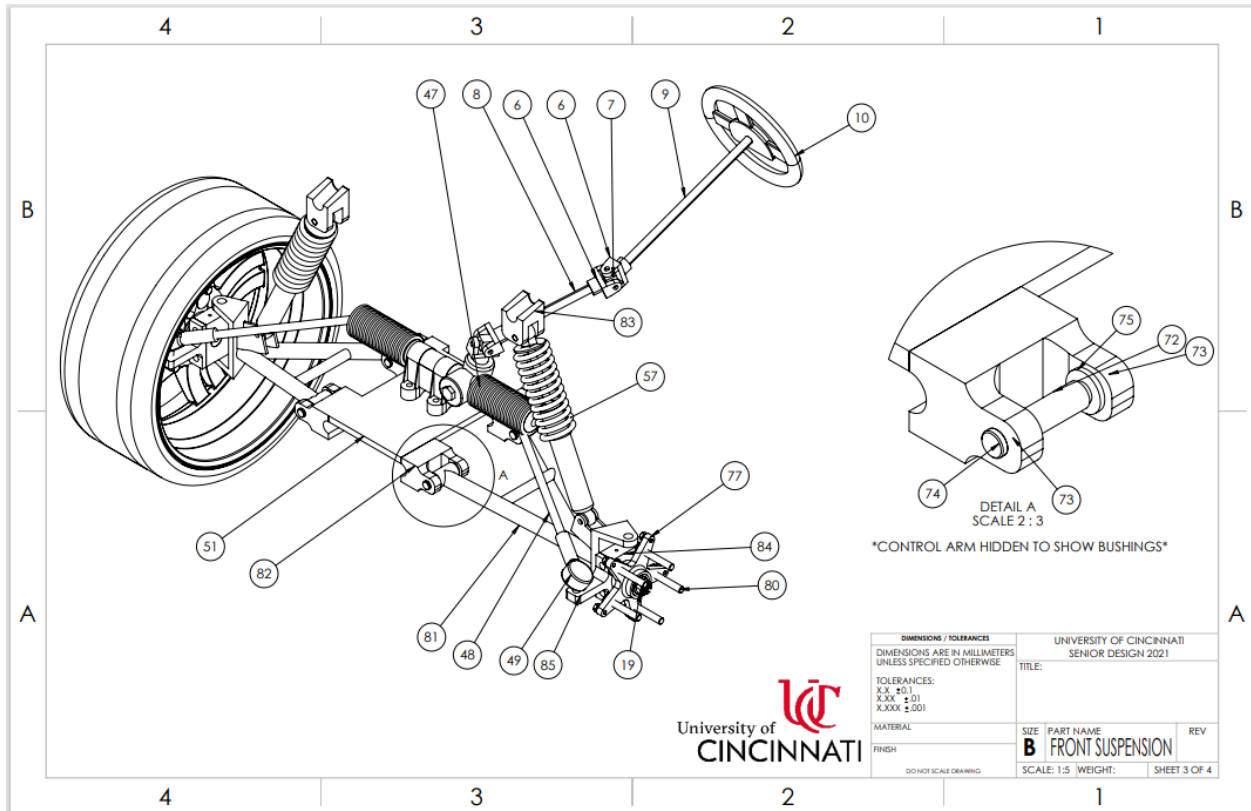

Figure 13: shows the completed front suspension and steering assembly

## Project Management

### Project Budget Limit

Given the purchased components that the group already has, and the frame already having been built, we set a budget limit of \$10,000 to complete this project.

### Key Milestones

Remaining Components Put on Order	11/30
Components Arrive	1/15
Assembly Start	1/20
Assembly and Testing 50%	3/20

### Total Brake and Panel Cost

Manufacturer	Model	Description	Distributor	Price
Tie Down Engineering	G5 SS brake	Disk Brake Assembly	West Marine	219.99
Streamline	Clear Braided Brake Line Kit	Brake Line Kit	PowerSports ID	61.05
Concentric	Grainger Model # 4F652	Hydraulic Gear Pump	Grainger	137.19
Lexan	Grainger Model # 1ETY3	3 Poly Carbonate Sheets, 8' * 4' * 1/4"	Grainger	1071.98
Alro Steel	Alro Part # 29211510	1020 HRS Sheet 3/16"	Alro Steel	966.04
McMaster Carr	MMC # 90131A553	Cushioned Washers	MMC	22.65

TOTAL COST = **2503.89**

## **Conclusion**

The overall scope of our project had changed rapidly due to the arising Covid-19 pandemic, and we had to shift our focus immensely from actually building this project, to simply designing the project and laying out the steps for the next group to take it on. The most I took from this project was the work on the brake setup as well as the calculations. It was very interesting to dig into it and use new concepts to creatively piece together a braking system that I know will work. That being said, I think the next group would have no problem with constructing this based off the resources we have provided them. I am sure they will have some changes here and there and I would love to see the finished work once completed.

## References:

1. Gator Utility Vehicles. John Deere. [Online] John Deere. [Cited: 4 September 2020]. <https://www.deere.com/en/gator-utility-vehicles/>.
2. Institute of Affordable Transportation. [Online] January 2010. [Cited: 4 September 2020]. [www.drivebuvo.org/buv-design](http://www.drivebuvo.org/buv-design).
3. Polaris Off-Road Vehicles (ORV): SxS, UTVs, ATVs, & 4-wheelers. [Online], [Cited 4 September 2020]. <https://offroad.polaris.com/en-us/>
4. SAWYERS, Harry, 2018, ATV vs. UTV: What Vehicle to Use When. *Popular Mechanics*. [Online]. 15 February 2018. [Cited: 4 September 2020]. <https://www.popularmechanics.com/cars/motorcycles/a6457/atv-vs-utv-vehicle-guide/>
5. GRABIANOWSKI, Ed, 2009, How Off-Road ATVs Work. *HowStuffWorks* [Online]. 5 October 2009. [Cited: 4 September 2020]. <https://adventure.howstuffworks.com/outdoor-activities/off-roading/off-road-atvs.htm>
6. Disc Brakes Vs. Drum Brakes: What's the Difference? [Online] [Cited: 15 September 2020]. <https://www.leithcars.com/blogs/1421/reviews/disc-brakes-vs-drum-brakes-whats-the-difference/#:~:text=Disc%20brakes%20were%20patented%20by,successful%20manufacture%20the%20necessary%20parts>.
7. 7. The Pros and Cons of Cars with Drum Brakes. [Online] [Cited 15 September 2020]. <https://haynes.com/en-gb/tips-tutorials/pros-and-cons-cars-drum-brakes/#:~:text=Drum%20brake%20advantages&text=Here%20are%20some%20advantages%20that,to%20manufacture%20than%20disc%20brakes>.
8. 8. Advantages and Disadvantages of Disc Brakes. [Online] [15 September 2020]. <https://www.bestscantool.net/advantages-disadvantages-disc-brakes/>
9. 9. ROBINSON, Matt, 2018, What Does a Servo Brake/ Brake Booster Actually Do? [Online] [15 September 2020]. <https://www.carthrottle.com/post/what-does-a-brake-servobrake-booster-actually-do>
10. 10. Overview of Materials for High Density Polyethylene, Extruded. [Online] [15 September 2020]. [http://www.matweb.com/search/datasheet\\_print.aspx?matguid=482765fad3b443169ec28fb6f9606660](http://www.matweb.com/search/datasheet_print.aspx?matguid=482765fad3b443169ec28fb6f9606660)
11. 11. Types of Braking Systems and Types of Brakes. [Online] [15 September 2020]. <https://www.automotive-technology.com/articles/types-of-braking-systems-and-types-of-brakes>

