

Boat Motor Mount/Stand

A Baccalaureate thesis submitted to the
Department of Mechanical and Materials Engineering
College of Engineering and Applied Science
University of Cincinnati

in partial fulfillment of the
requirements for the degree of

Bachelor of Science

in Mechanical Engineering Technology

by

Noah Schmidhammer

April 2021

Thesis Advisor:

Professor Moise Cummings

TABLE OF CONTENTS

TABLE OF CONTENTS.....	II
LIST OF FIGURES	III
LIST OF TABLES	III
ABSTRACT.....	IV
PROBLEM DEFINITION AND RESEARCH	1
PROBLEM STATEMENT	1
RESEARCH.....	1
BACKGROUND AND SCOPE OF THE PROBLEM	1
CURRENT STATE OF THE ART	3
END USER.....	6
CONCLUSIONS AND SUMMARY OF RESEARCH.....	6
QUALITY FUNCTION DEPLOYMENT	7
CUSTOMER FEATURES	7
ENGINEERING CHARACTERISTICS.....	7
HOUSE OF QUALITY	8
PRODUCT OBJECTIVES.....	9
DESIGN	10
DESIGN ALTERNATIVES AND SELECTION	10
ENGINEERING CALCULATIONS	12
MANUFACTURING DRAWINGS	13
.....	13
BILL OF MATERIAL.....	15
BUILD AND TEST	15
DISCUSSION OF THE MANUFACTURING PROCESSES UTILIZED	15
TEST PROCEDURE AND CRITERIA	18
TEST RESULTS AND FINDINGS	18
PROJECT MANAGEMENT.....	19
BUDGET, PROPOSED/ACTUAL.....	19
SCHEDULE, PROPOSED /ACTUAL	20
SUSTAINABILITY AND MATERIAL USAGE.....	20
CONCLUSIONS.....	21
WORKS CITED	22
APPENDIX A.....	23
SAMPLE SURVEY	23
APPENDIX B	24
FINAL BUILD	24

LIST OF FIGURES

(Figure 1 - Outboard Heavy Duty Boat Motor Stand Carrier by Costway).....	3
(Figure 2 - C.E. Smith Outboard Motor Dolly Stand)	4
(Figure 3 - Wooden DIY stand)	5
(Figure 4 - House of Quality).....	8
(Figure 5 - Design Alternative 1).....	10
(Figure 6 - Design Alternative 2).....	11
(Figure 7 – Selected Design).....	12
(Figure 8 - Top Half of Base)	13
(Figure 9 - Bottom Half of Base).....	13
(Figure 10 - Actuator Cutout, Center Piece).....	14
(Figure 11 - Pipe Cutout, Center Piece).....	14
(Figure 12 - Base Welding).....	15
(Figure 13 - Center Piece).....	16
(Figure 14 - Pipe, Outside).....	17

LIST OF TABLES

(Table 1 – Functionality Test Results)	18
(Table 2 – Proposed Budget vs. Actual Spending)	19
(Table 3 – Initial Schedule vs. Actual Schedule)	20

ABSTRACT

This is a two-person senior design project for the Mechanical Engineering Technology class of 2021. My partner was Aaron Clark. Aaron and I chose to do this project because we have seen with our own eyes how much of a struggle maintaining and handling boat motors can be. Aaron's grandfather owns a boat and performs routine maintenance, often struggling and even injuring himself. After seeing few options in the market and nothing that addressed the problems associated with handling a boat motor, we decided to build our own. Designing and fabricating our own mount tested our engineering skills and ability to work together.

This semester was much different than most, as we had no in-person classes and were forced to work completely virtual. This proposed many challenges and forced us to find alternate ways to complete our project. Using our knowledge and engineering practices we designed and fabricated an all-in-one boat motor mount that incorporates the necessary features for easy use.

In terms of design, I was responsible for the functionality of the mount. This means making sure the mount has the ability to elevate (height adjustment) and rotate. Aaron was responsible for the base/frame of the mount and making sure it could incorporate features such as height adjustment of rotation.

PROBLEM DEFINITION AND RESEARCH

PROBLEM STATEMENT

Current boat motor stands are bulky and do not include all the necessary features a boat owner requires. Stands lack the ability to rotate, elevate, and collapse. This creates unnecessary and additional work and safety hazards for boat owners.

RESEARCH

BACKGROUND AND SCOPE OF THE PROBLEM

From experience and online reviews, it is hard to access certain areas of the motor with the structure of the stand in the way.

There are a variety of users this product would be affecting. There is a total of 17 million recreational boats—13 million registered, plus 4 million unregistered—currently in use in the United States [3]. According to the Statista Research Department, the average age of use for an outboard boat is fifty-four years old [6]. Nevertheless, not all outboard boat motor stands work the same. While some are sturdy and appear to be built with a lot of passion, others are flimsy and are likely to make transporting motors harder than before [2].

The importance of this issue varies depending on the capability of the user working on their boat motor when maintenance is needed. The outboard boat motor stands that are in the market have a dolly like design with a cross bar that acts as a support bar. These stands average sixty to ninety dollars on the market. None of these designs have a 360-degree rotating feature, and an ability to adjust the height.

Without these features, people handling and making adjustments on their boat motors are prone to injury or strenuous work. Adding features to elevate and rotate the motor as needed provides users with features needed to easily work on their boat motors.

The current solutions are inadequate. Bulky structures and a cross bar with side beam design creates blind spots for boat owners. Transportation of the motor on these stands is dangerous due to the fact one must lean everything back to maneuver the motor. The current stands in the market are large, taking up a lot of room, making transportation of the stands much more difficult.

CURRENT STATE OF THE ART

Dolly style with wheels: Below is a 315lbs Outboard Heavy-Duty Boat Motor Stand Carrier Cart Dolly by Costway. Four 8" rear wheels and two 3" universal caster wheels for transport, this motor carrier can easily carry 315lb [1]. This is a dolly-like design with a main crossbar that is the support for the motor. This design creates a large blind spot in the motor that is unable to perform maintenance on. This structure is also very static, as it is not collapsible and lacks any feature to rotate, adjust, and elevate the motor. This stand technology is not a suitable solution for the problem.



(Figure 1 - Outboard Heavy Duty Boat Motor Stand Carrier by Costway)

Collapsible dolly style: C.E. Smith Outboard Motor Dolly is a collapsible boat motor stand that can support up to 250lbs and fits up to 25 hp motors [4]. This is a similar stand to the first example, except this stand is collapsible. Being able to collapse gives the user the ability to travel with the stand, as well as taking up much less space for storage. Since this stand is collapsible, it cannot hold as much weight as a structural stand can. This technology also does not have the ability to rotate, adjust, or elevate the motor. This stand is on the expensive side of the spectrum and includes features like wheels and collapsibility for transportation/storage, which others do not. Although this stand is on the expensive side, it still is not a suitable solution.



(Figure 2 - C.E. Smith Outboard Motor Dolly Stand)

Wooden DIY stand: Perhaps the most common design is a simple wooden DIY stand made from 2” x 4”. This design is commonly used because it can be made from 2” x 4”s and is very inexpensive. Since 2” x 4”s are much bulkier than sheet metal or metal rods, this technology, more than others, blocks certain areas of the motor (as seen in image below). This technology is the most limited of the three selected as it performs no other feature except holding the stand upright. This means the stand does not have the ability to: collapse or easily disassemble, rotate for access to all parts of the motor, or elevate for access and ease of use. This technology does not provide a suitable solution as the stand is very limited and does not provide everything needed.

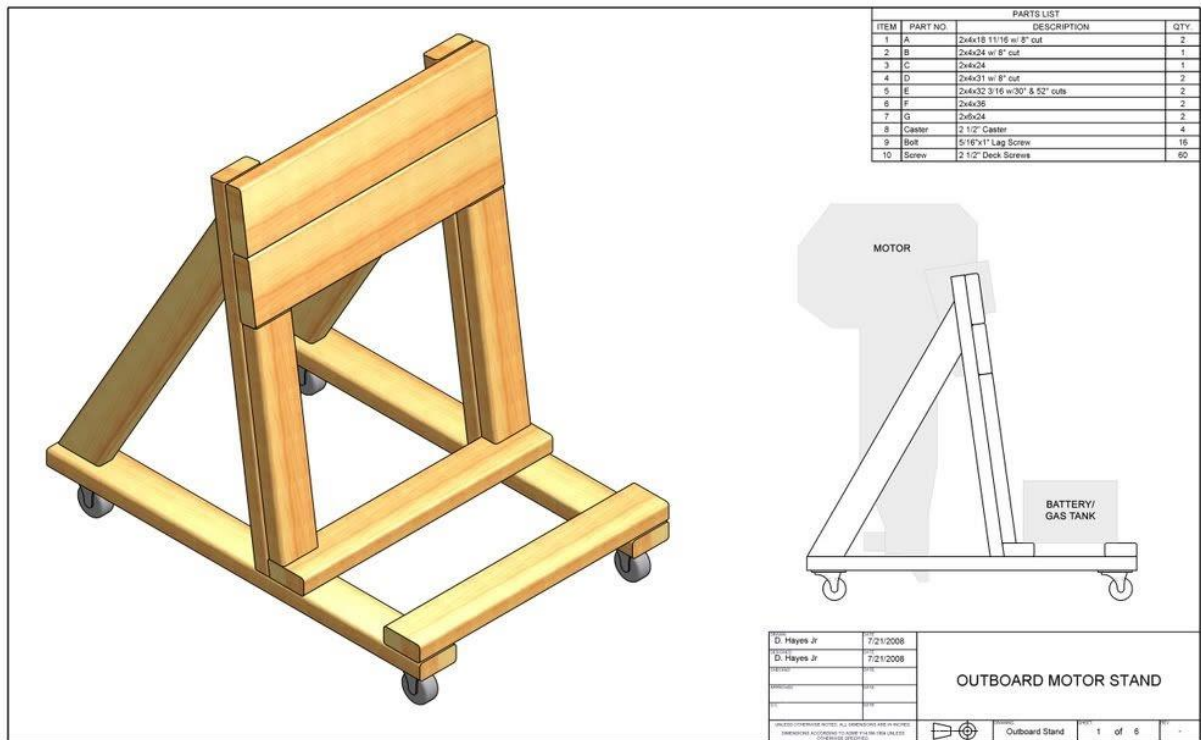

(Figure 3 - Wooden DIY stand)

END USER

The end user for a boat motor stand is anyone who owns an outboard boat. The need to store the motor and the need to perform maintenance makes a boat motor stand a necessity for anyone who owns an outboard boat. Proper cleaning, routine maintenance, and seasonal storage are all needs for a boat motor stand from boat owners. According to Statista, male boat owners outnumber female boat owners, seven to one [5]. This makes the end user much more likely to be male than female.

CONCLUSIONS AND SUMMARY OF RESEARCH

In conclusion, the technologies in the market today are not adequate solutions to the problems experienced by boat owners. Boat stand technologies lack the inclusiveness of all the features necessary to make a boat stand as useful as possible. This can be attributed to cost. Research shows that people do not want to spend more than a few hundred dollars on a boat motor stand, hence why so many people create DIY stands. An ideal solution would include a small footprint stand that has the ability to rotate, elevate, and collapse, all while sustaining its ability to carry heavy motors. These features are not seen in today's technology, therefore there is not a suitable solution.

QUALITY FUNCTION DEPLOYMENT

CUSTOMER FEATURES

Aesthetic

Cost

Safety

Ease of Use

Maneuverability

Overall Size

ENGINEERING CHARACTERISTICS

Degrees of possible rotation

Height Range Selection

Time to setup/collapse

Material Selection

Load Capacity/Limit

Weight

HOUSE OF QUALITY

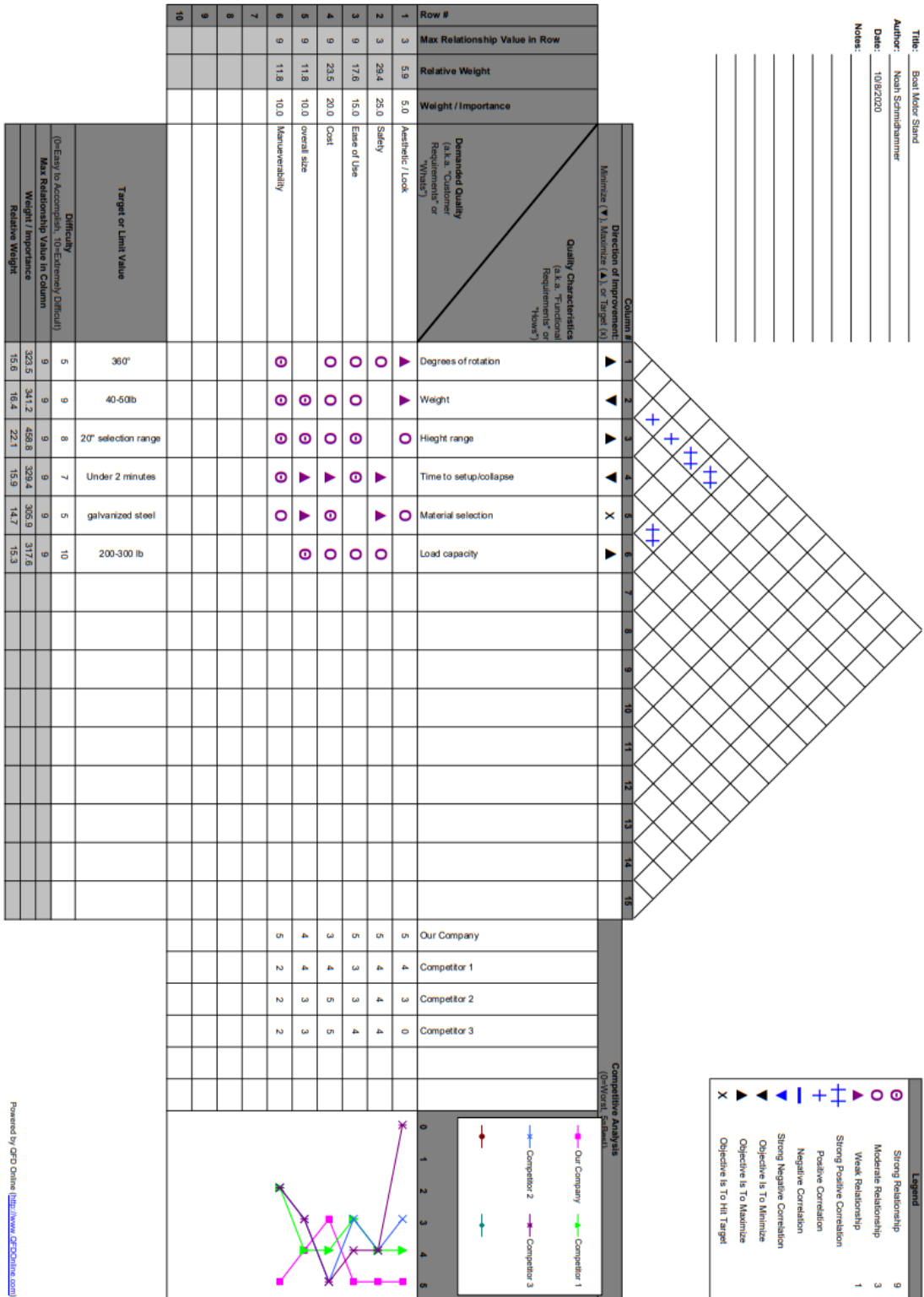

(Figure 4 - House of Quality)

PRODUCT OBJECTIVES**Aesthetic - (5.9%)**

This feature has to do with the final “look” of the product, and how the system's appearance is as a whole.

Cost - (23.5%)

The amount of money a new boat motor stand technology should cost. The cost should be kept as low as possible while maintaining the other features required.

Safety - (29.4%)

The boat motor stand will be safe to use in any conditions.

Ease of Use - (17.6%)

Design orientation and a wireless controller will give the end user an easy system to operate.

Maneuverability - (11.8%)

Ability to rotate and elevate the motor will give the end user the maneuverability to perform whatever is needed on their boat motor.

Overall Size - (11.8%)

The size of the stand will be appropriate to that of the size of the motors they carry. The material selection and design will affect the overall size of the stand.

DESIGN

We chose to proceed with the design in Figure 7. The model in Figure 7 provides the most strength while also maintaining the ability to rotate and elevate. It has a small footprint and is easy to disassemble.

DESIGN ALTERNATIVES AND SELECTION

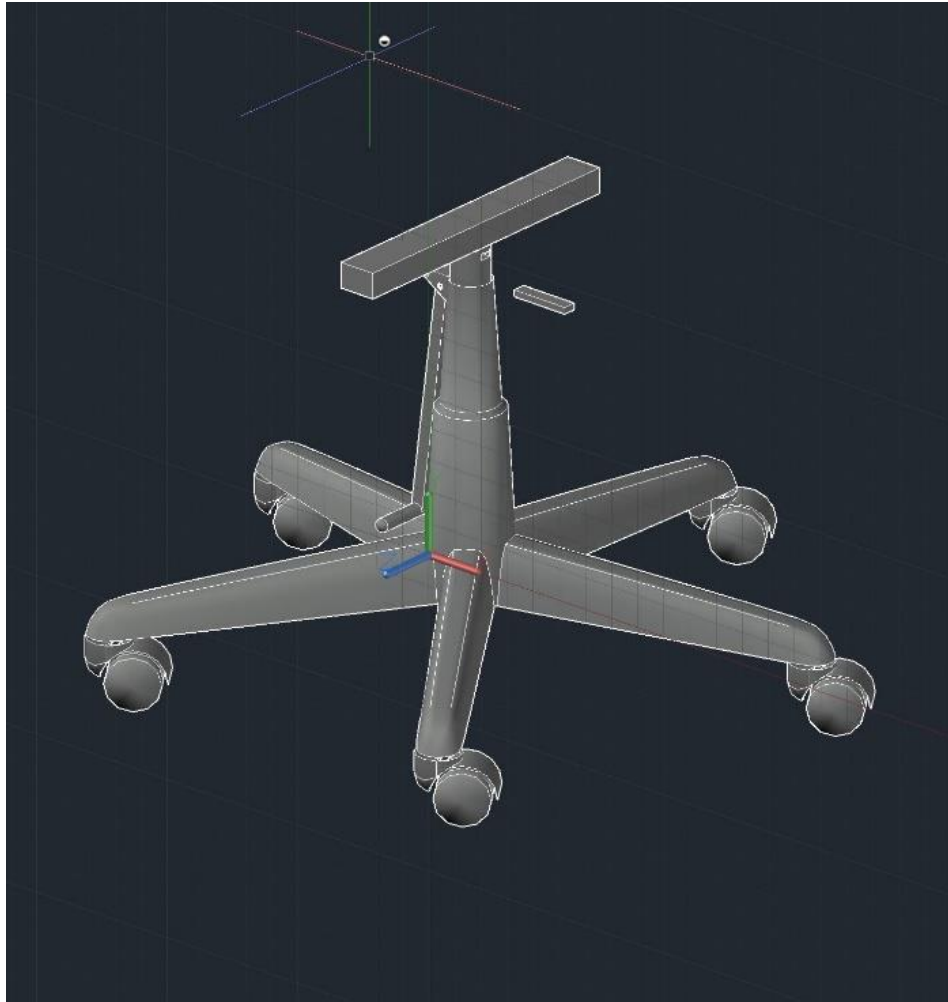

(Figure 5 - Design Alternative 1)

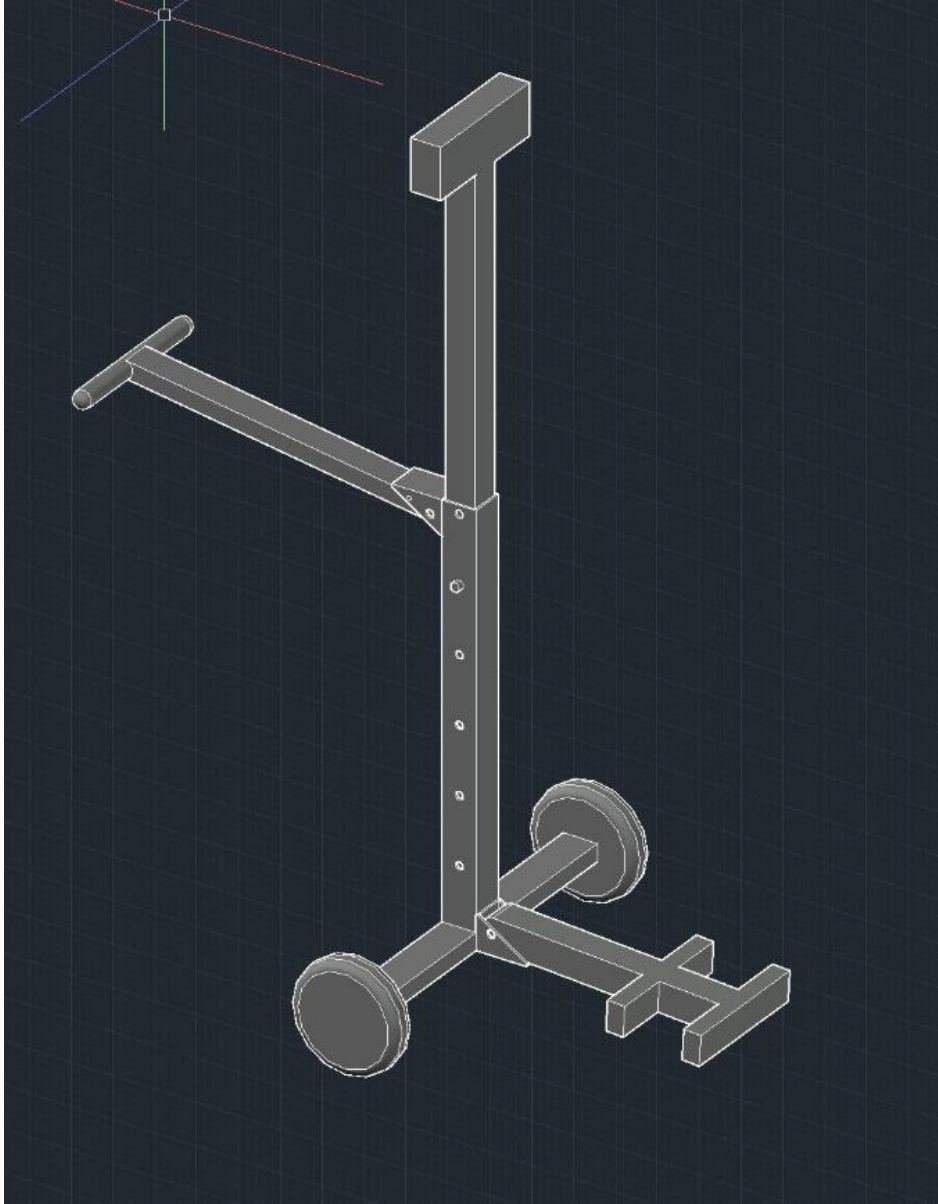

(Figure 6 - Design Alternative 2)

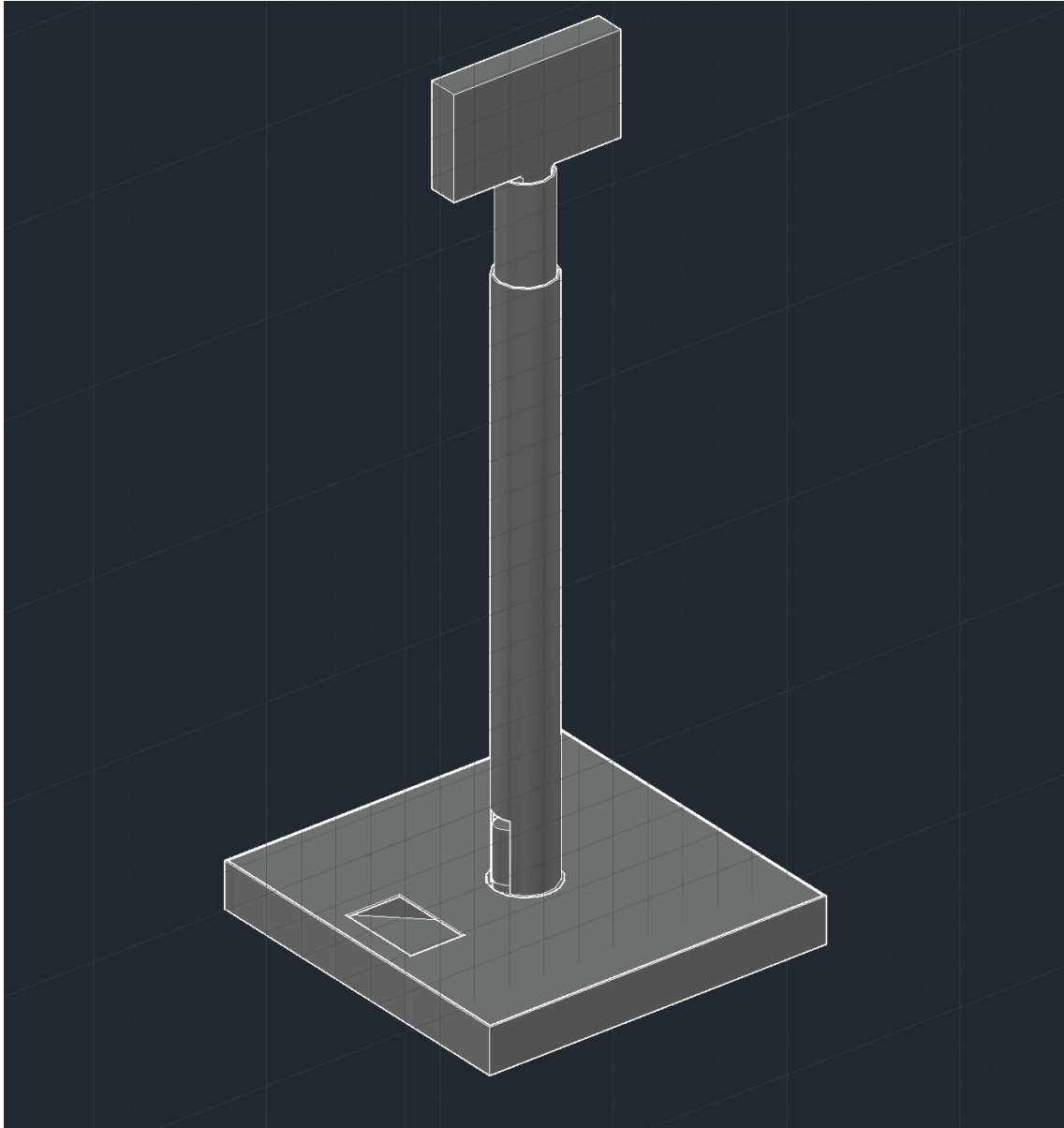

(Figure 7 – Selected Design)

ENGINEERING CALCULATIONS

Force needed by actuator to lift 2 stroke boat motor:

$$\sum F_y = -130\text{lbs} - 35\text{lbs} - 10\text{lbs} = -175\text{lbs}$$

Force needed by actuator to lift 2 stroke boat motor is 175lbs. Our actuator selection has a max load of 660lbs.

$$\text{Factor of Safety} = 660/175 = 3.7$$

MANUFACTURING DRAWINGS

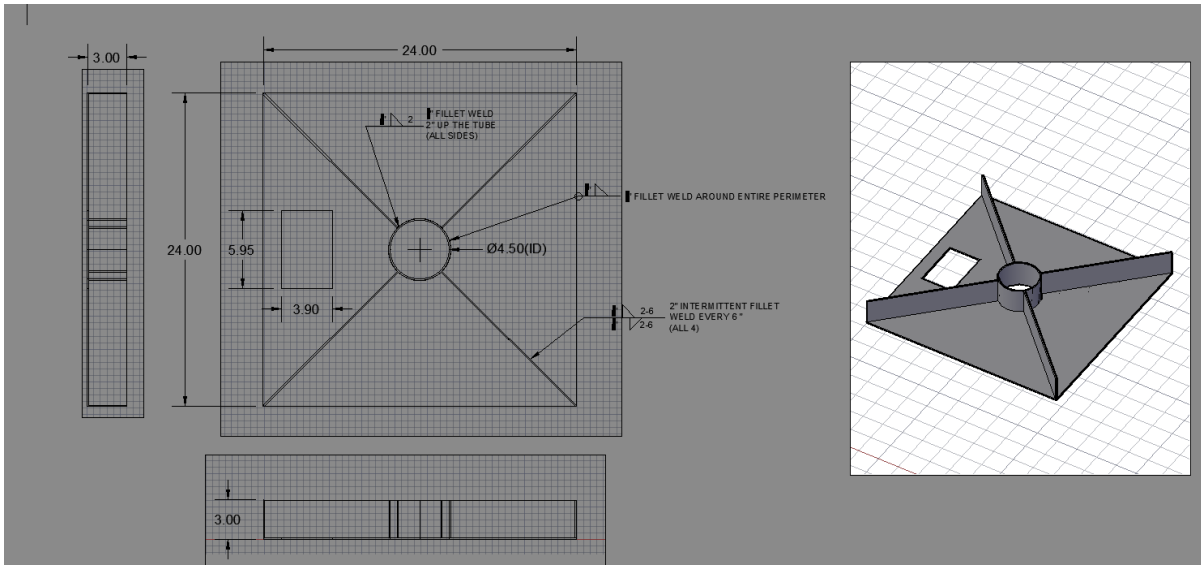

(Figure 8 - Top Half of Base)

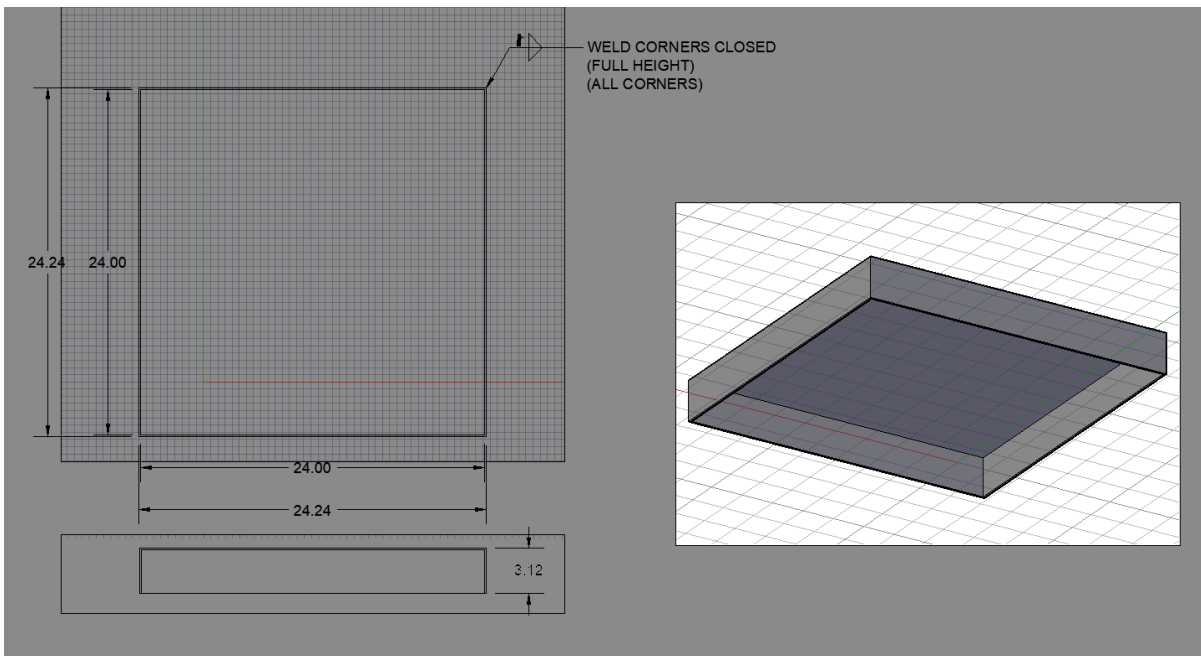

(Figure 9 - Bottom Half of Base)

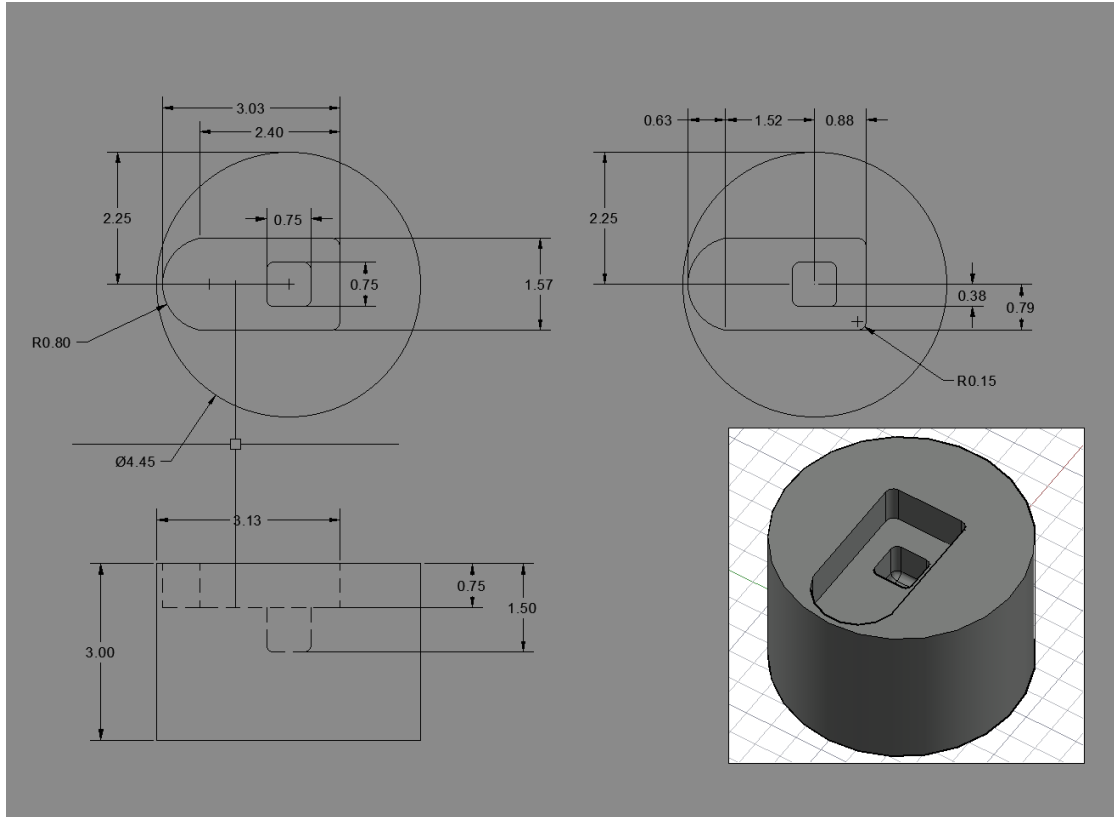

(Figure 10 - Actuator Cutout, Center Piece)

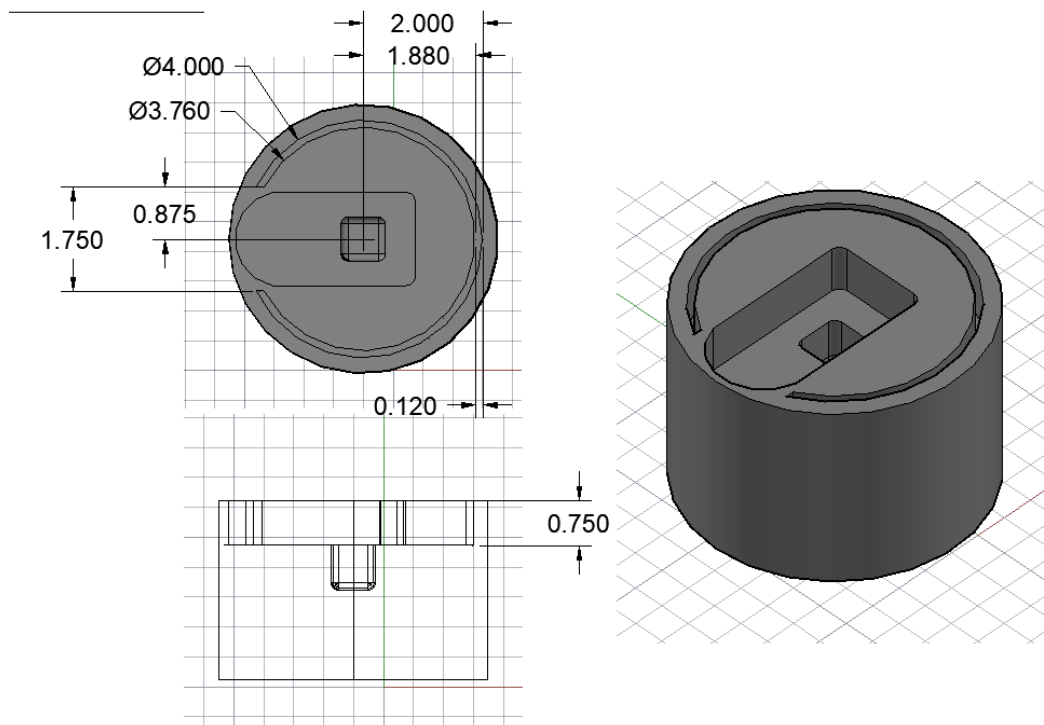

(Figure 11 - Pipe Cutout, Center Piece)

BILL OF MATERIAL

Heavy duty linear actuator

Wireless controller kit

12V battery

Needle roller thrust bearing

4.5" diameter rod, 3" long

4.5" diameter pipe, 3" long

4" diameter pipe, 6' long

3.5" diameter pipe, 6' long

12 ga carbon steel sheet

5/16" diameter rod, 12" long

2" thick wood, cut to size/shape

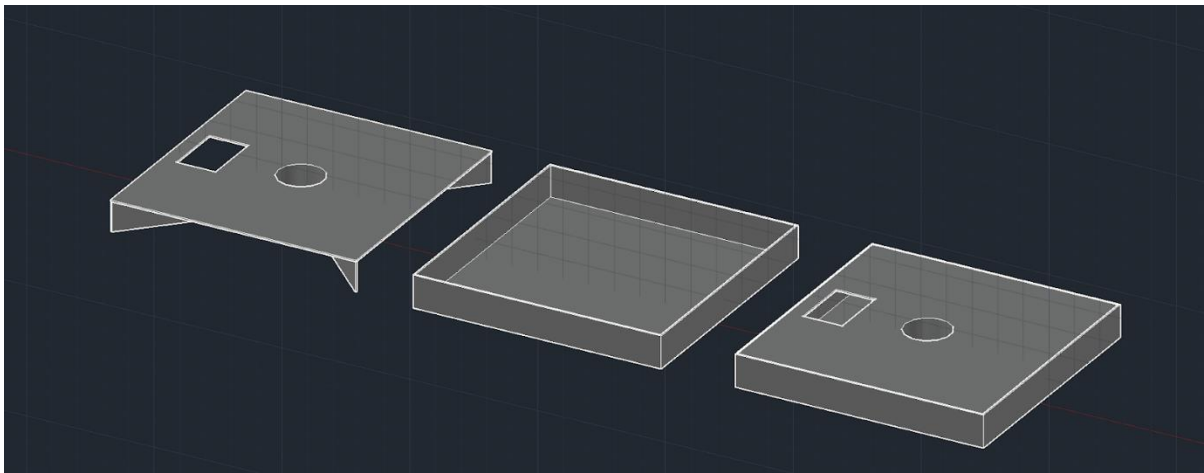
BUILD AND TEST***DISCUSSION OF THE MANUFACTURING PROCESSES UTILIZED***

(Figure 12 - Base Welding)

The base is 2 pieces welded together as seen above. The top piece (far left) is inserted into the bottom piece(middle), then welded shut. The welding is 1/8" fillet weld, MIG welding.

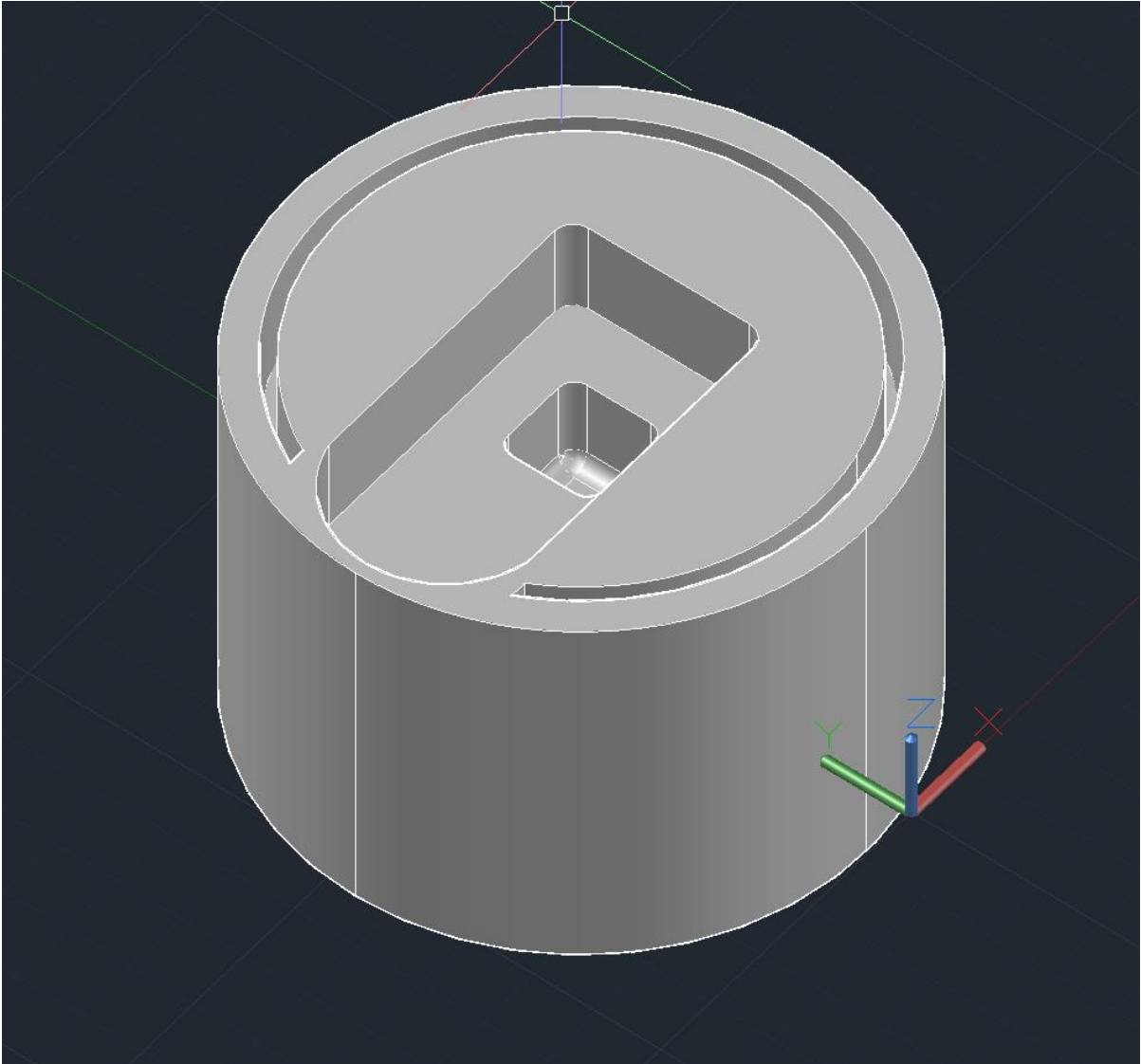

(Figure 13 - Center Piece)

In Figure 12 above is the center piece. The center piece is what the actuator and pipe are slotted into. This piece was a 4.5" diameter, 3" long, easy to machine, aluminum rod machined using a CNC and lathe. The CNC was used to machine the slots for the pipe and the actuator, while the lathe was used to machine the diameter down .05" to fit snug into the base.

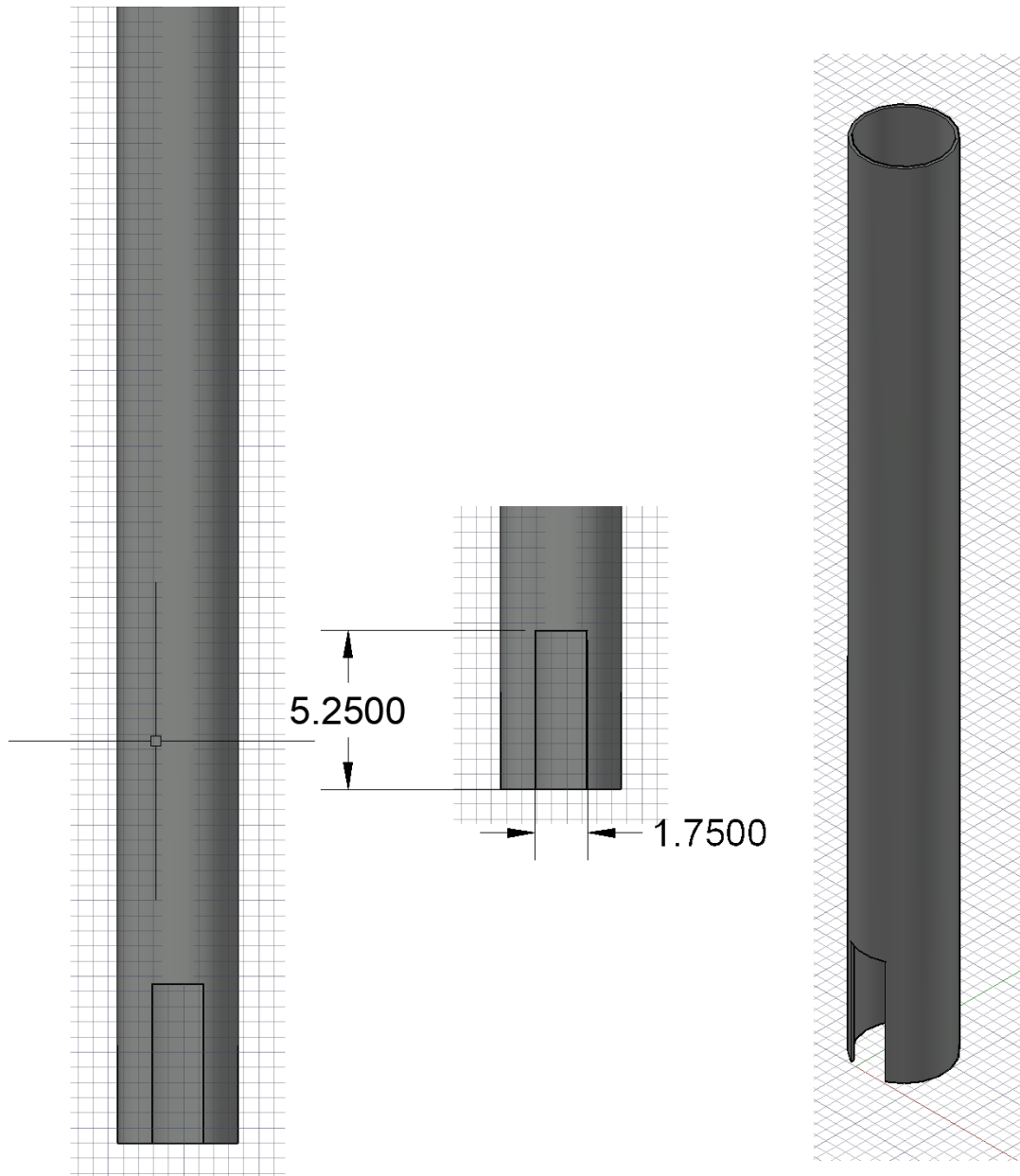

(Figure 14 - Pipe, Outside)

In Figure 13 above is the outside pipe that is slotted for the actuator to reach the battery. The slot was machined using a circular saw. The pipes were cut to length using a band saw.

TEST PROCEDURE AND CRITERIA

Testing of our stand included loading a 110lb boat motor on the stand and adding increments of 20lbs. We added 20lbs to the power head of the motor, so it was relatively centered. For each increment we test the complete functionality of the mount. This includes adjusting the height from minimum to maximum, while rotating the mount continuously. We also tested the range of the wireless controller by walking away from the mount slowly until we lost connection.

TEST RESULTS AND FINDINGS

Test #	Weight added (lbs.)	Total weight (lbs.)
1	0	110
2	20	130
3	40	150
4	60	170
5	80	190
6	100	210

(Table 1: Functionality Test Results)

Our test results exemplify the strength of our mount. The mount was able to retain complete functionality while holding the maximum tested load of 210 lbs. This means the mount was able to raise from minimum to maximum height while being able to rotate continuously.

These results also indicate the mount is operating with a factor of safety of at least 2, making it reliable and safe. The maximum range of the wireless controller was 35 feet.

PROJECT MANAGEMENT

BUDGET, PROPOSED/ACTUAL

<u>Proposed Budget</u>		<u>Actual Spending</u>	
Item	Cost	Item	Cost
Long Stroke Electric Linear Actuator w/ Controller	\$160	Long Stroke Electric Linear Actuator	\$130
12V Battery	\$35	Wireless controller kit + 12V Battery	\$40
6' x 3" and 6' x 3.25" Aluminum Piping	\$160	Carbon Steel Pipes	\$180
Custom Manufactured Parts	\$200	Sheet Metal + Welding	\$240
Hardware and tools	\$20	Center Piece (Holding for Actuator)	\$50
Misc.	\$50	Misc.	\$30
Total	\$625	Total	\$675

(Table 2 – Proposed Budget vs. Actual Spending)

Total amount spent ended up being relatively similar to our proposed budget from Senior Design II. We were able to save money by conducting more research to find the best actuator for our application, at the cheapest price. What pushed our actual spending over our proposed budget was fabricating the base. We did some redesigning to our base and ended up spending more on sheet metal and welding than anticipated. When redesigning our base, we added a new part called the center piece. This added \$50 onto our budget since it was a new add. Even with a few changes to design, we were able to stay very close to our initial proposed budget.

SCHEDULE, PROPOSED /ACTUAL

<u>Initial Schedule</u>		<u>Actual Schedule</u>	
Item	Date	Item	Date
Begin ordering sheet metal, pipes, actuator etc.	Dec. 15 2020	Began ordering sheet metal, pipes, actuator etc.	Jan. 3 2021
Configure Actuator/Battery/Controller	Jan. 15 2021	Configure Actuator/Battery/Controller	Jan. 15 2021
Machining/Welding	Jan. 29 2021	Begin Engineering Drawings	Jan. 29 2021
Begin Assembly	Feb. 8 2021	Machining/Working with welder	Feb 16. 2021
Complete Final Assembly	Feb. 19 2021	Complete Final Assembly	Mar. 24 2021
Testing	Mar. 5 2021	Testing	Apr. 5 2021
Adjustments/Modifications	Mar-Apr. 2021		

(Table 3 – Initial Schedule vs. Actual Schedule)

The biggest issue we faced was getting a late start. We planned to meet and begin working during the winter break, but ultimately ended up waiting for the semester to start. This pushed us back in our schedule, but since we allowed so much time for assembly, we were able to catch up and complete the project on time. The most time-consuming aspects were getting the engineering drawings completed and spending time in the machine shop.

SUSTAINABILITY AND MATERIAL USAGE

In terms of efficiency, there are a few places we could have been more sustainable. First, we purchased pipes in lengths of 6', then cut them to size, just to make sure we had long enough pieces. In hindsight, we could have modeled and determined exactly what size we need the

pipes cut to. This would have saved material and time in the machine shop.

We also could have purchased thinner pipes. As seen in the test results above our mount was able to withstand our largest load and perform all functionality. These results show that the mounts pipes are heavy duty enough to withstand a load much larger than needed for our application and could have possibly been overkill.

CONCLUSIONS

Our final product is one that accomplishes a lot of what we wanted. We successfully designed a boat motor mount that has the ability to rotate continuously, as well as elevate with a range of 28", from 46" minimum height to 74" maximum height. Our mount is extremely safe and was able to function at all weights tested. The wireless controller allows users to easily adjust the mount as needed. Rotating the mount is easy, safe, and prevents the user from any blind spots. Compared to the other mounts in the market today, our mount is easily the most useful and safest mount out there. Our mount provides everything one could want in a boat motor mount except for wheels.

Where we fell short in terms of customer needs was price. Our final product is by far the most useful mount but is not realistic in terms of price. This product is more of a specialty product that is used for people who have a very strong need for it. The price is too high for it to be a mass market product.

Overall, our boat motor mount is an adequate solution to problems encountered by boat owners. Our stand incorporates the ability to rotate and elevate, as well as collapse for storage. In order to achieve these results, we had to sacrifice putting wheels on it, and sacrifice a low price point.

WORKS CITED

1. Miyachi Products. [Online] Miyachi America Corporation. <http://www.miyachiamerica.com/>.
2. IAI Quality and Innovation. [Online] Intelligent Actuator. <http://www.intelligentactuator.com/>.
3. Costway. 315 lbs Outboard Heavy Duty Boat Motor Stand. *Costway*. [Online] October 10, 2020. <https://www.costway.com/315-lbs-outboard-boat-motor-stand-carrier-cart-dolly-storage-pro-heavy-duty.html?fee=110>.
4. Generic Surplus. 5 Best Outboard Motor Stands in 2020. *Generic Surplus*. [Online] July 14, 2020. [Cited: September 29, 2020.] <https://genericsurplus.com/best-outboard-motor-stands/>.
5. NMMA. U.S. Recreational Boating Industry Sees Seventh Consecutive Year of Growth in 2018. *National Marine Manufacturers Association*. [Online] 1 10, 2019. [Cited: October 4, 2020.] <https://www.nmma.org/press/article/22428>.
6. Cabelas. C.E. Smith Outboard Motor Dolly. *Cabelas*. [Online] [Cited: September 29, 2020.] https://www.cabelas.com/shop/en/ce-smith-outboard-motor-dolly?ds_e=GOOGLE.
7. Statista Research Department. Average age in years of new boat buyers in the United States in 2015, by boat propulsion type. *Statista*. [Online] August 1, 2016. [Cited: September 10, 2020.] <https://www.statista.com/statistics/466343/age-of-boat-buyers-in-the-us-by-propulsion/>.
8. —. Share of Americans owning a boat in 2018, by age. *Statista*. [Online] January 21, 2020. [Cited: September 10, 2020.] <https://www.statista.com/statistics/369961/people-living-in-households-that-own-a-boat-usa/>.
9. Mcglynn, Fiona. What Women Want in Boating. *Boat U.S.* [Online] November 2018. [Cited: September 10, 2020.] <https://www.boatus.com/magazine/2018/october/what-women-want-in-boating.asp>.

APPENDIX A

SAMPLE SURVEY

Boat Motor Stand

This survey will be used to prioritize various features to maximize customer satisfaction. The system in question will address issues when working on a boat motor, also addressing the comfortability and accessibility of the motor.

How important to you is each feature in a boat motor stand?

1 = Very Unimportant

5 = Very Important

Aesthetic - **1**

Cost - **4**

Safety - **5**

Ease of Use - **3**

Maneuverability - **2**

Overall Size - **2**

How satisfied are you with the current boat motor stands on the market?

1 = Very Unsatisfied

5 = Very Satisfied

Aesthetic - **2**

Cost - **4**

Safety - **3**

Ease of Use - **3**

Maneuverability - **3**

Overall Size - **3**

How much would you be willing to pay for a new boat motor stand technology?

\$100-\$400, \$400-900, \$900-1400

APPENDIX B
FINAL BUILD

