

Ulsan, Republic of Korea

# **Interaction Between Client and Design Consultant: The Stance of Client to Design Consultant and Its Influence on the Design Process**

**Haebin Lee, Muhammad Tufail, Myungjin Kim, KwanMyung Kim\***  
**Ulsan National Institute of Science & Technology,**



# Contents

- Introduction
- Research framework
- Case studies and analysis
- Findings and Conclusions
- Discussion

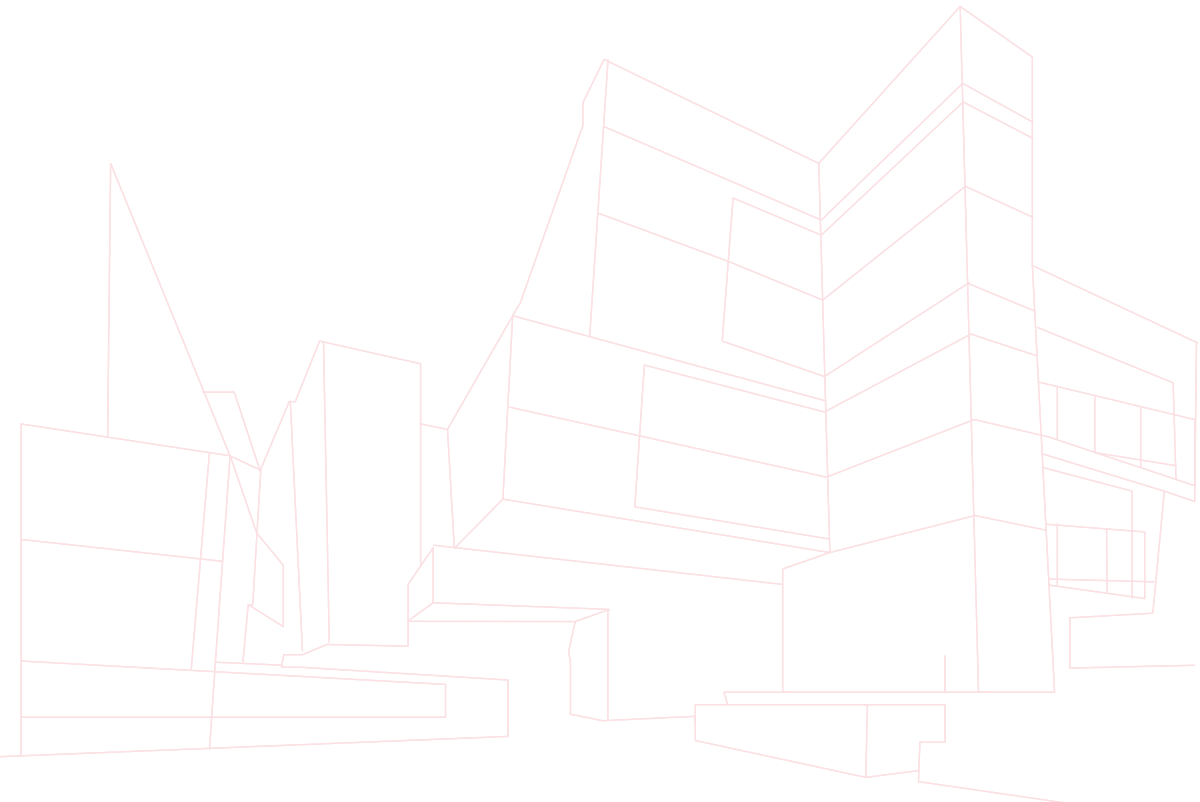

# Introduction

Background : Design competency

**Large Cap/ Large  
Proprietary Company**

**Small and Medium size  
Enterprise (SME)**



# Introduction

Background : Design competency

**Large Cap/ Large  
Proprietary Company**

- Enough design competence

**Small and Medium size  
Enterprise (SME)**



# Introduction

Background : Design competency

## Large Cap/ Large Proprietary Company

- Enough design competence
- Operate their own industrial and engineering design teams

## Small and Medium size Enterprise (SME)



# Introduction

Background : Design competency

## Large Cap/ Large Proprietary Company

- Enough design competence
- Operate their own industrial and engineering design teams

## Small and Medium size Enterprise (SME)

- Weak design competence



# Introduction

Background : Design competency

## Large Cap/ Large Proprietary Company

- Enough design competence
- Operate their own industrial and engineering design teams

## Small and Medium size Enterprise (SME)

- Weak design competence
- Utilize external designers to gain competitive advantages as a business strategy

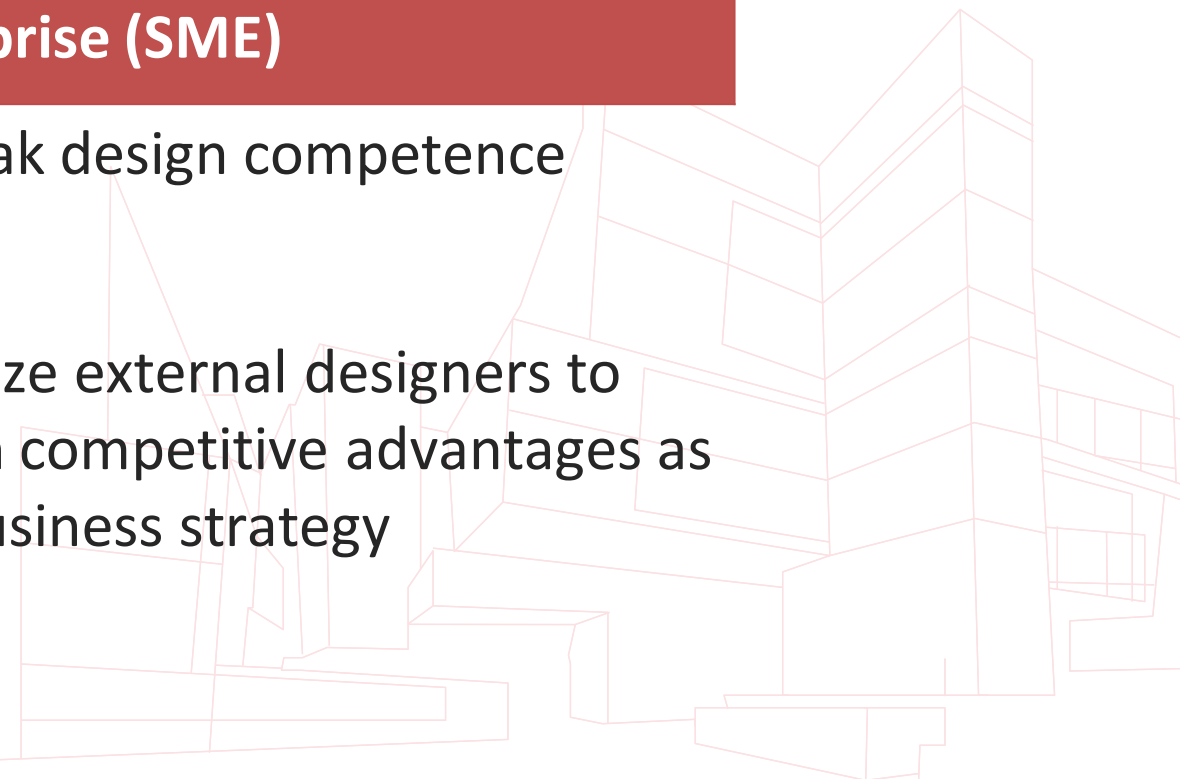

# Introduction

Background : Relationship between Designer and Client (SME)

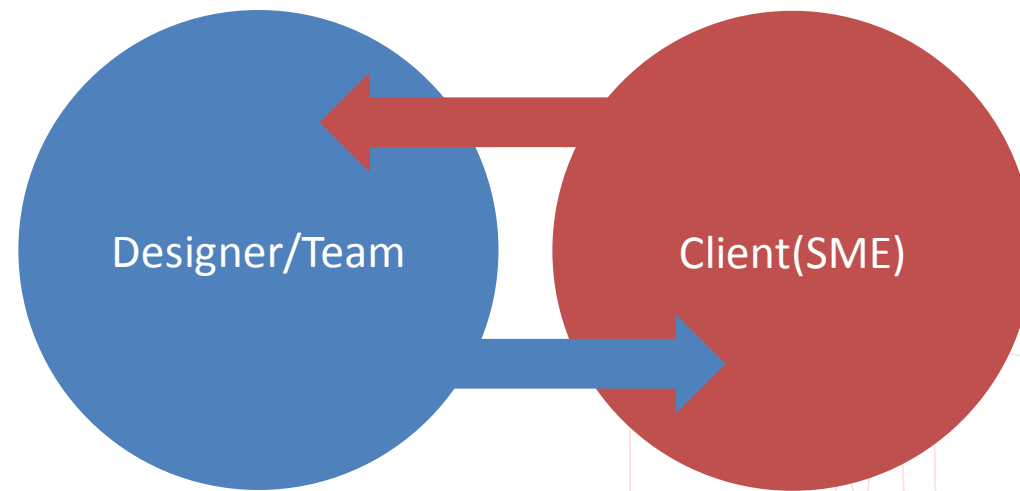

# Introduction

Background : Relationship between Designer and Client (SME)

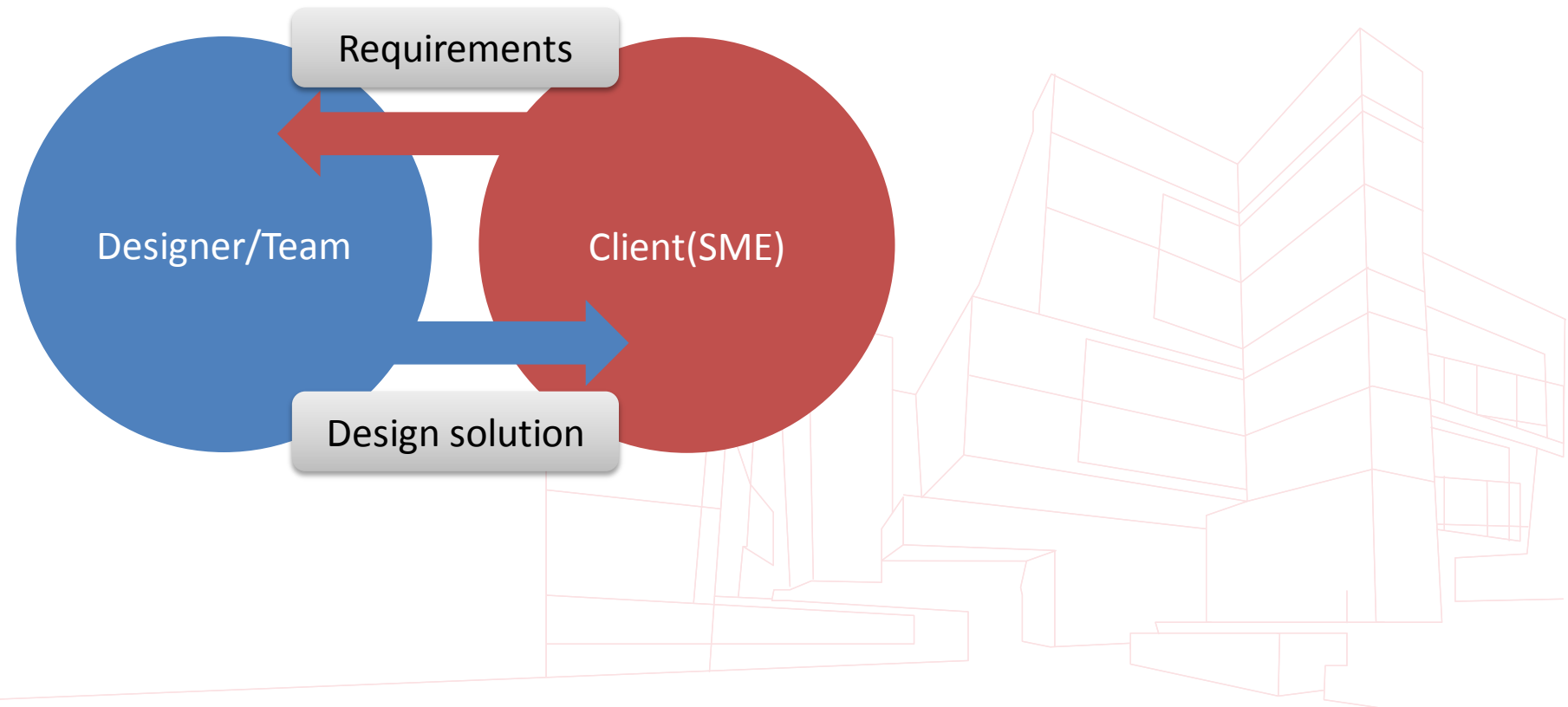

# Introduction

## Research aims

- What is the **Relationship** between client and designer in product development
- How does this relationship **influence** design process/outcome



# Research Framework

How to measure the relationship between Clients and Designers/ design team?

- Relationship between designer-client: **Contract relationship**

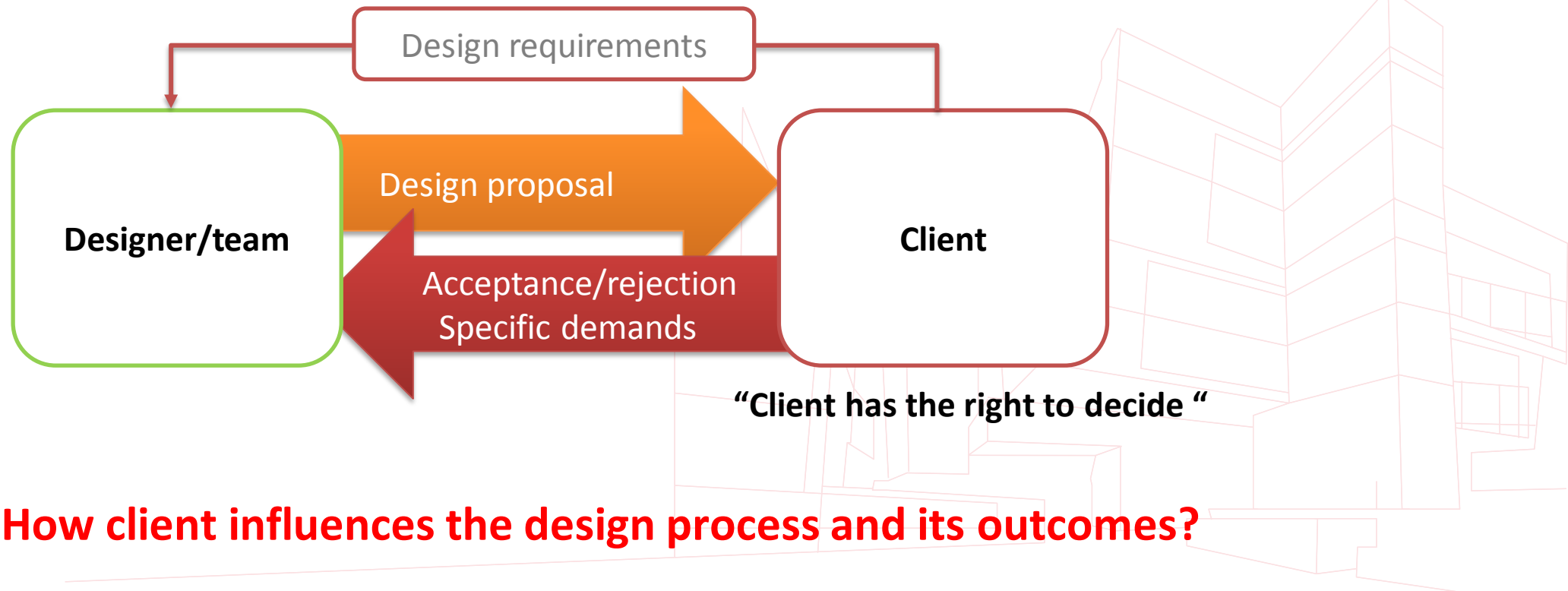

→ How client influences the design process and its outcomes?

# Research Framework

How to measure the relationship between Clients and Designers/ design team?

- Client's participation on design process

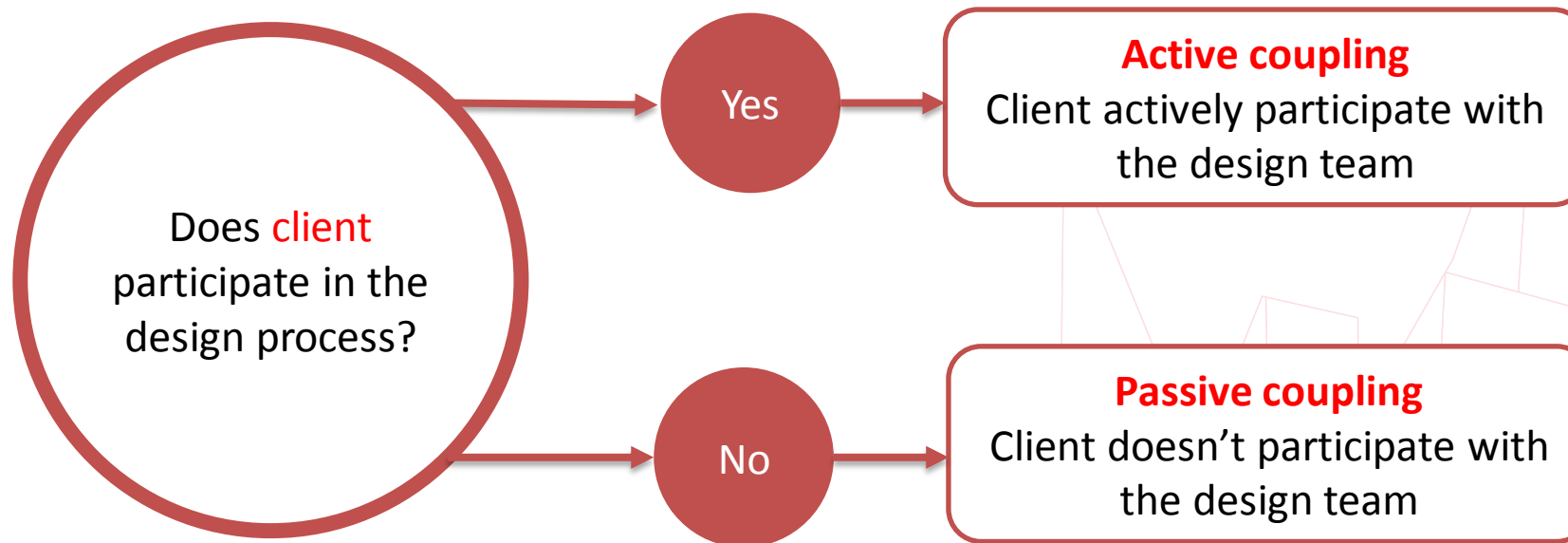

- Gericke and Maier (2011)

# Research Framework

How to measure the relationship between Clients and Designers/ design team?

- Client's participation on design process

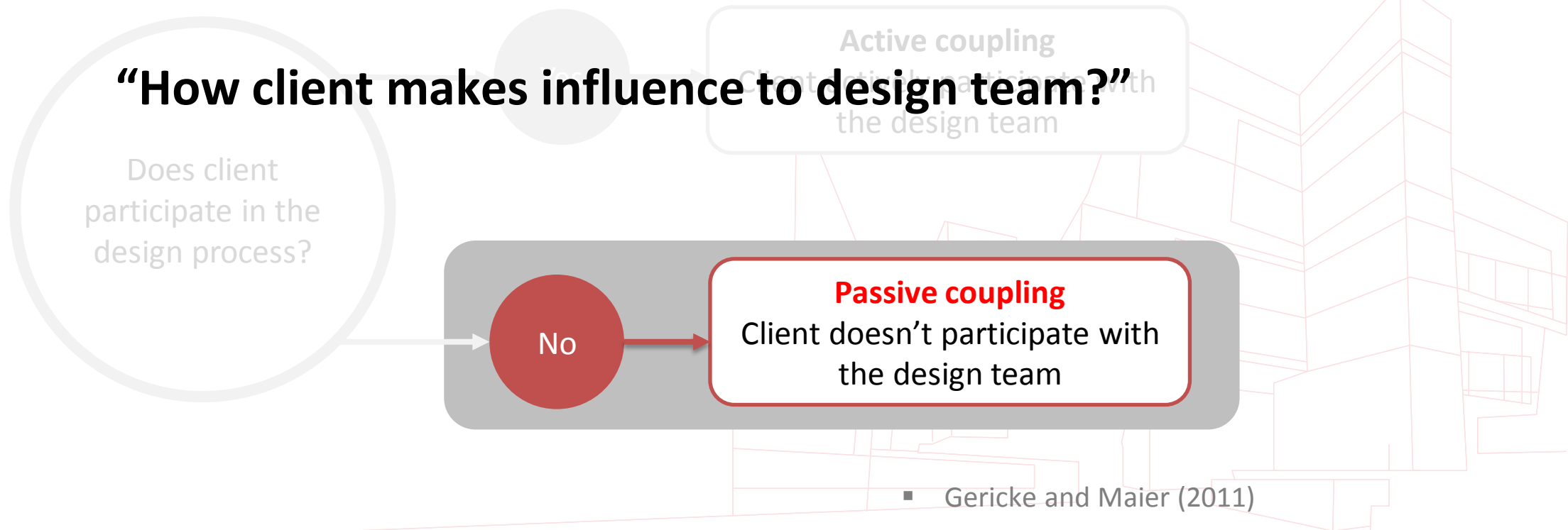

# Research Framework

How to measure the relationship between Clients and Designers/ design team?

- Client's **STANCE** about **design team**:

## The expressive stance

- Clients express ideas or intentions continuously to exercise their influence over the design team

Ex)

- Reject design proposal
- Provide further information to fulfill their intention
- Put forward their own draft to modify and revise the design elements

## The receptive stance

- Clients accept and recognize the decisions made by the design team

Ex)

- Accept design proposal



# Research Framework

How to measure the relationship between Clients and Designers/ design team?

- Client's **STANCE** about **design team**:

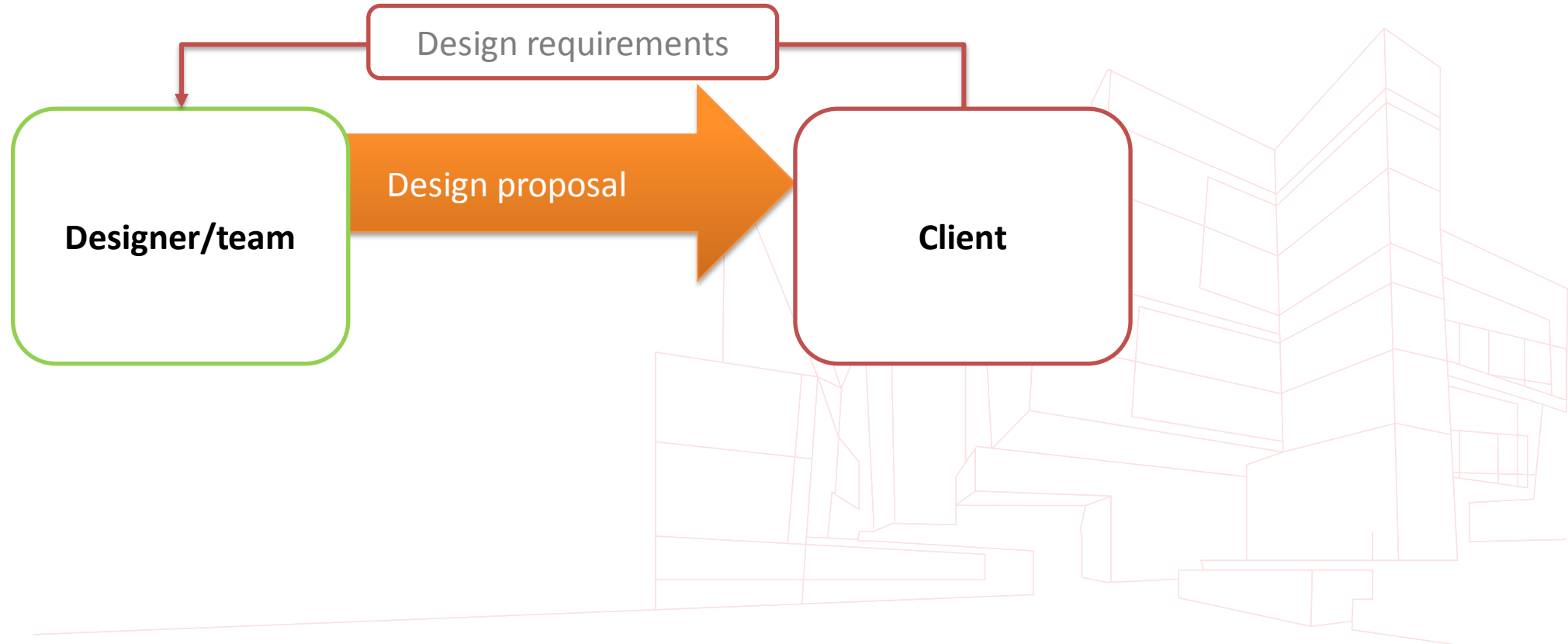

# Research Framework

How to measure the relationship between Clients and Designers/ design team?

- Client's **STANCE** about **design team**:

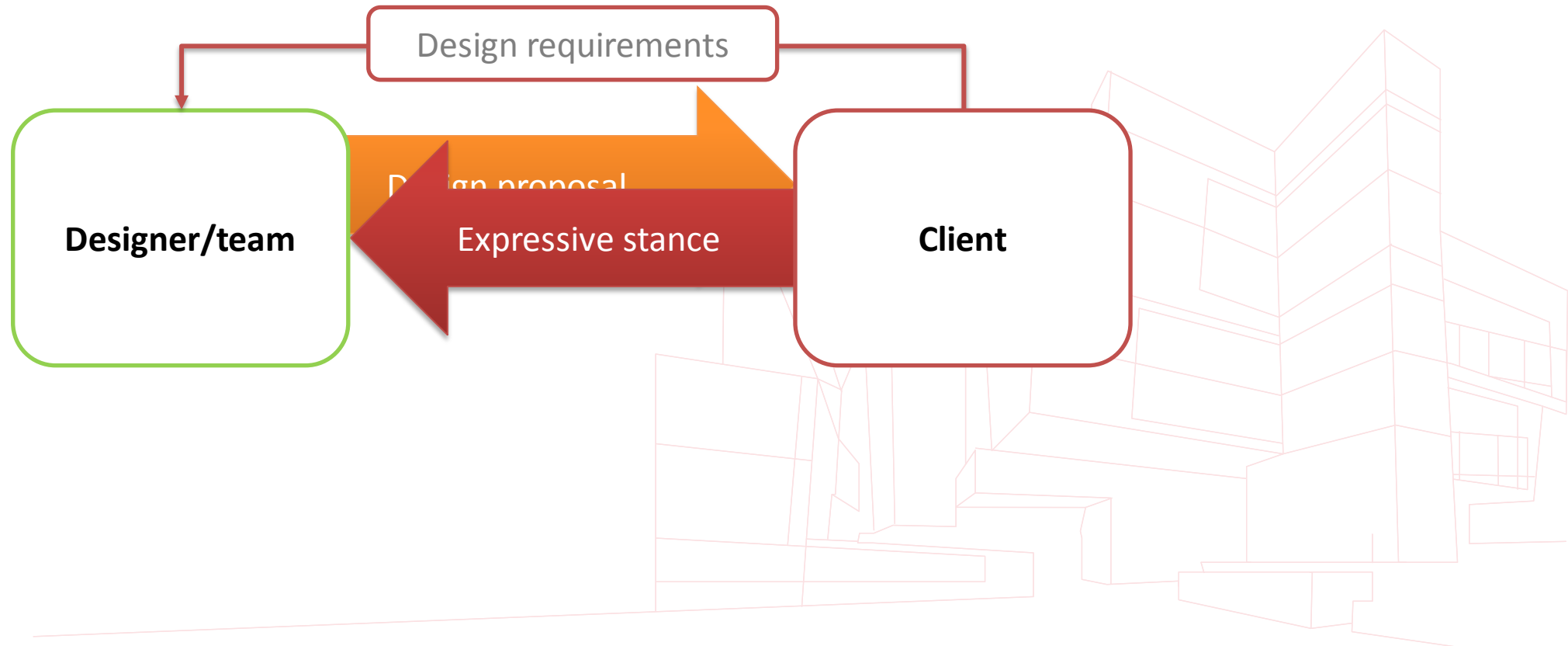

# Research Framework

How to measure the relationship between Clients and Designers/ design team?

- Client's **STANCE** about **design team**:

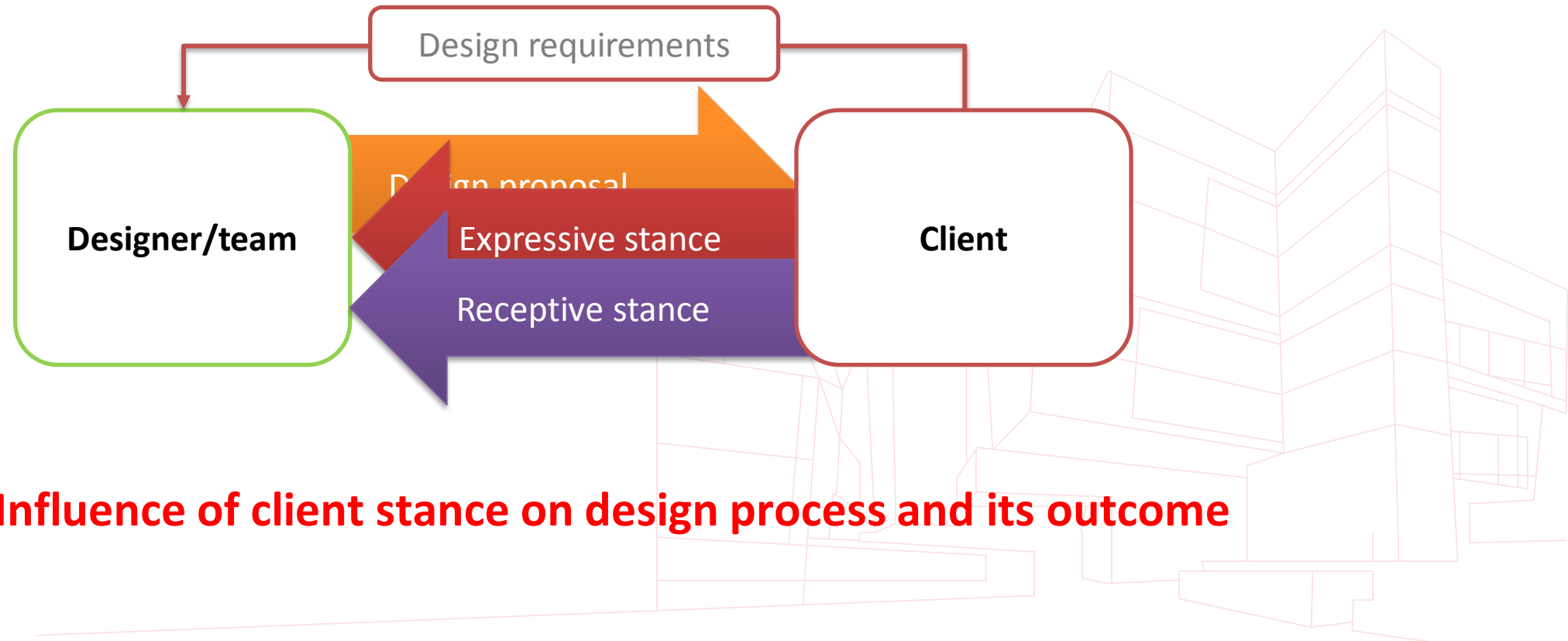

→ Influence of client stance on design process and its outcome

# Case Studies and Analysis

- Design Project Profiles
- A joint collaboration with the design team of UNIST

<b>Year of projects</b>	2014 - 2016
<b>No. of enterprises</b>	Three
<b>Type of enterprise</b>	Technology-based (Inventor CEO)
<b>No. of employees per enterprise</b>	Less or equal to five

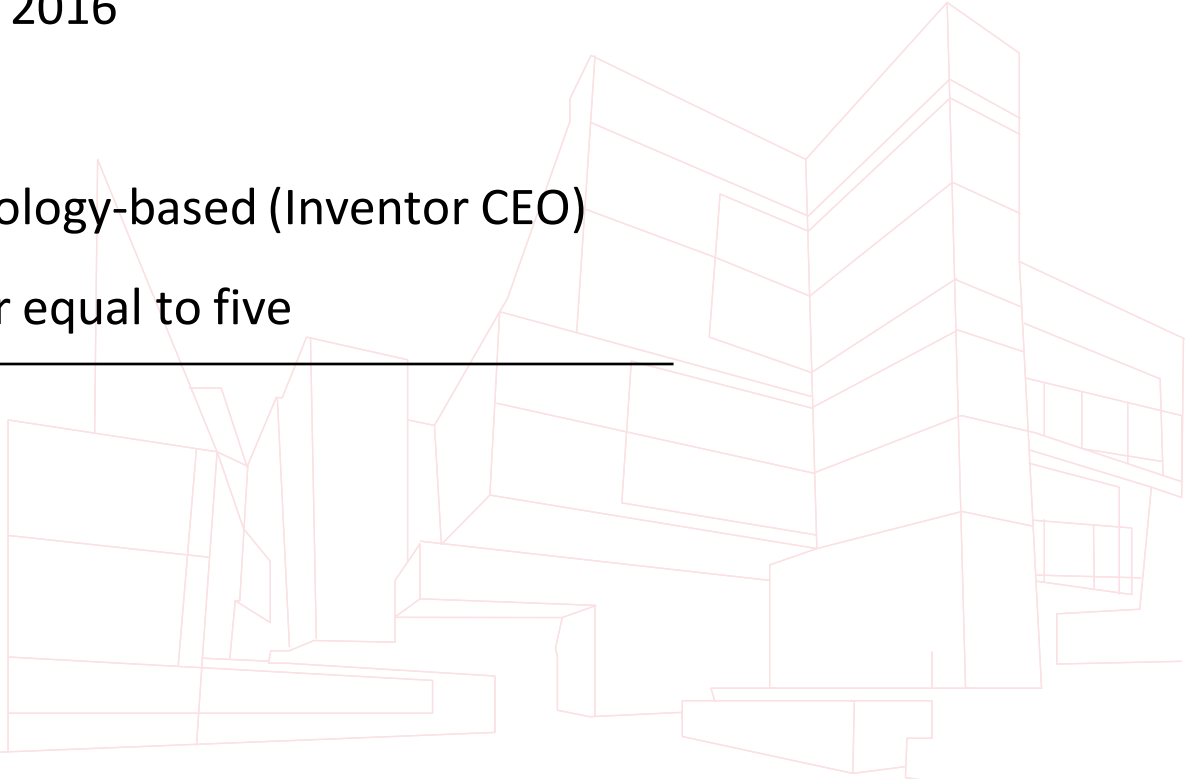

# Case Studies and Analysis

## Design Project 1: a recliner chair

- Client's request

**“Design a recliner chair”**

- With the drawings , patent specifications, and test prototypes

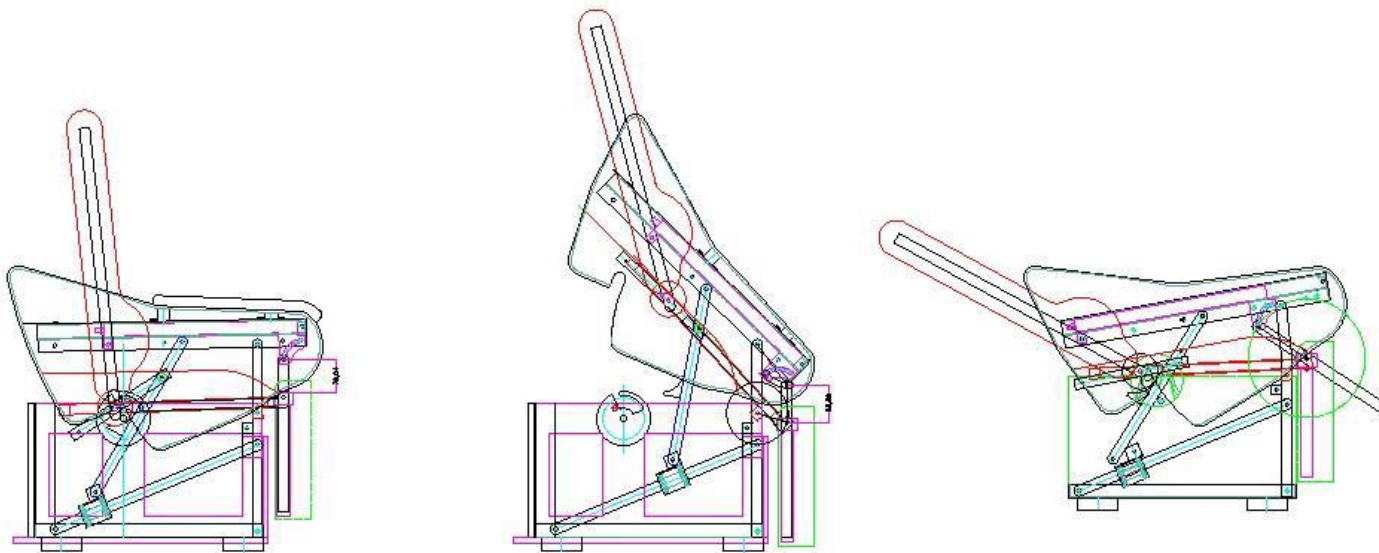

# Case Studies and Analysis

## Design Project 1: a recliner chair

- Expressive stance
- Receptive stance

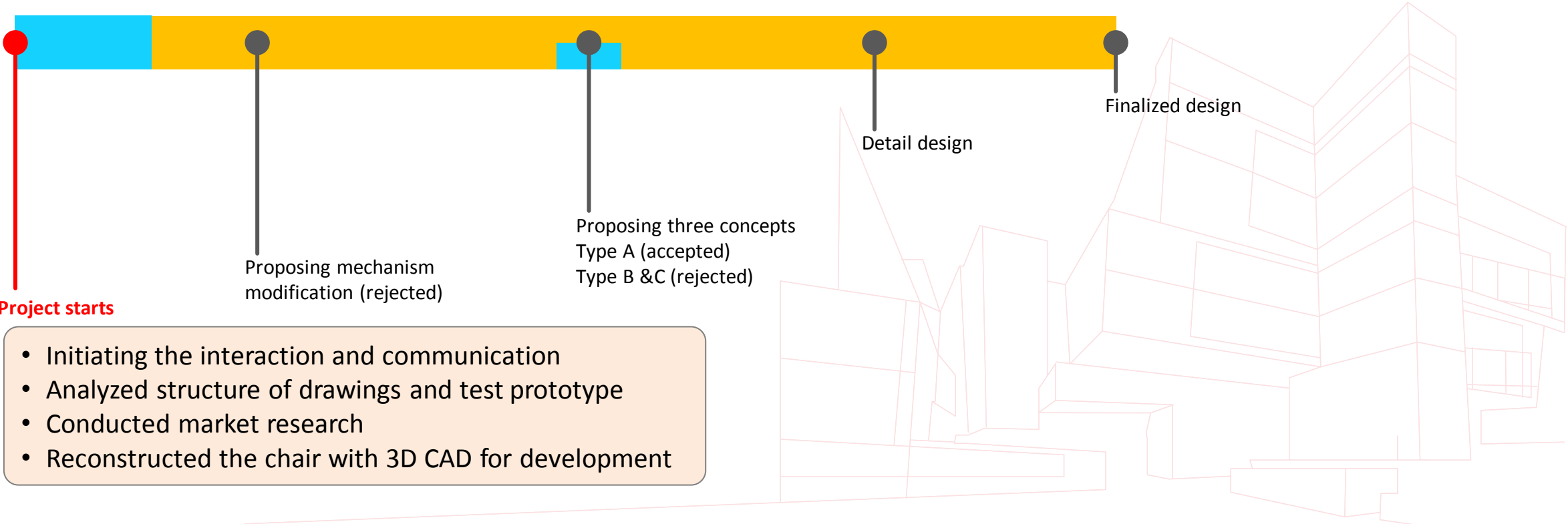

# Case Studies and Analysis

## Design Project 1: a recliner chair

- Expressive stance
- Receptive stance

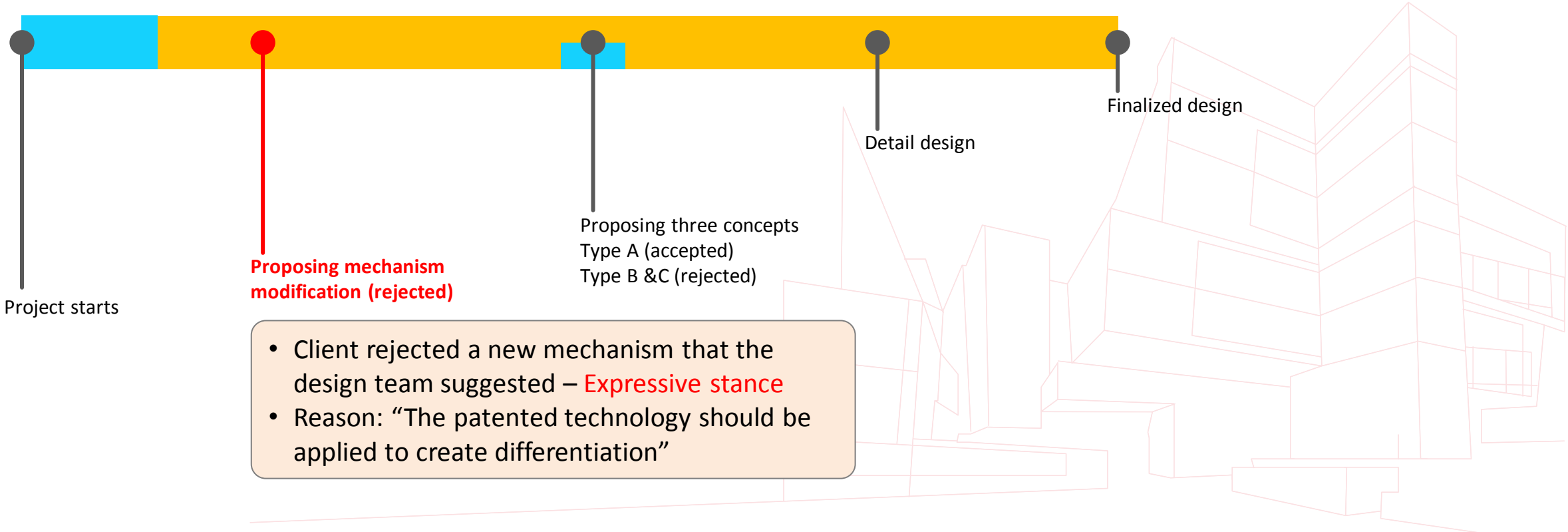

# Case Studies and Analysis

## Design Project 1: a recliner chair

- Expressive stance
- Receptive stance

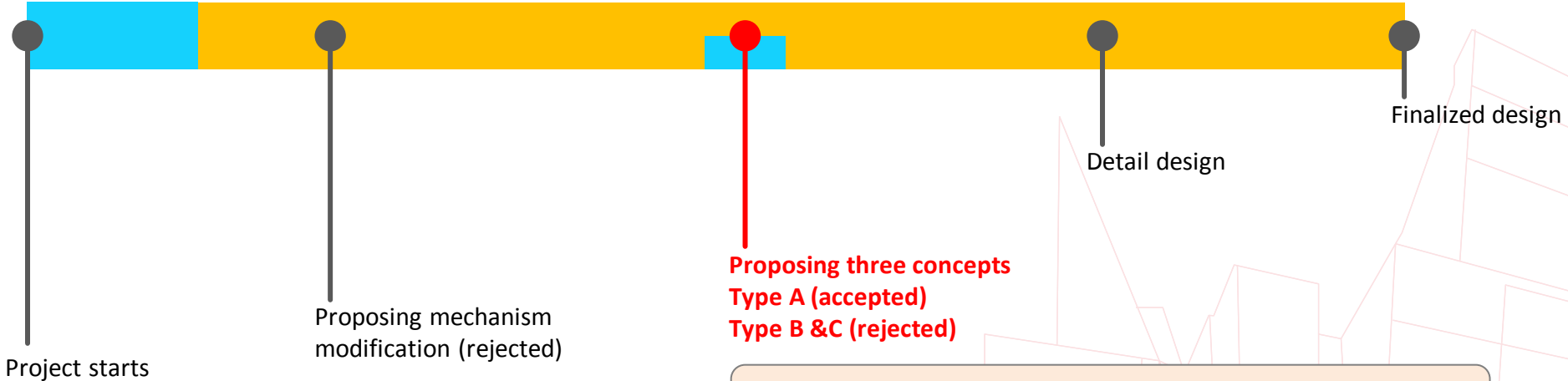

Proposing three concepts  
Type A (accepted)  
Type B & C (rejected)

- Design team preferred Type B and C based on the market research, but they were rejected.
- Client adopted Type A to suit their preference



# Case Studies and Analysis

## Design Project 1: a recliner chair

- Expressive stance
- Receptive stance

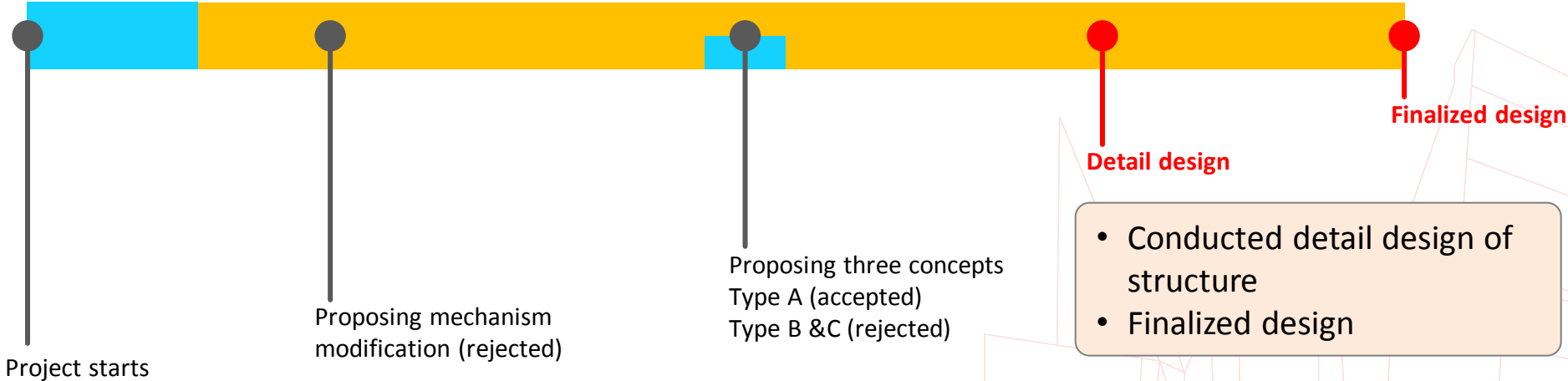

- Conducted detail design of structure
- Finalized design



# Case Studies and Analysis

Design Project 1: a recliner chair

“Client’s stance?”

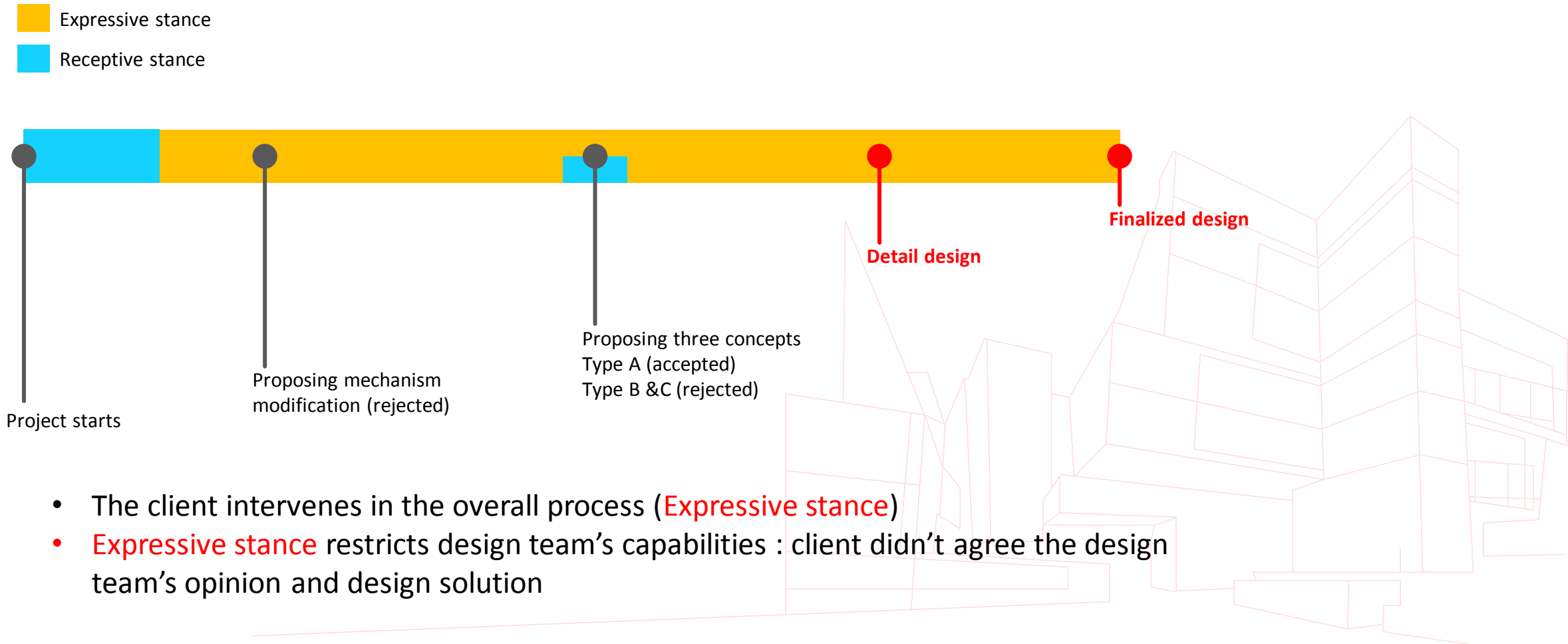

# Case Studies and Analysis

## Design Project 2: a Multi-functional baby carrier

- Client's request

“Design a Baby carrier”

- With the patent specifications

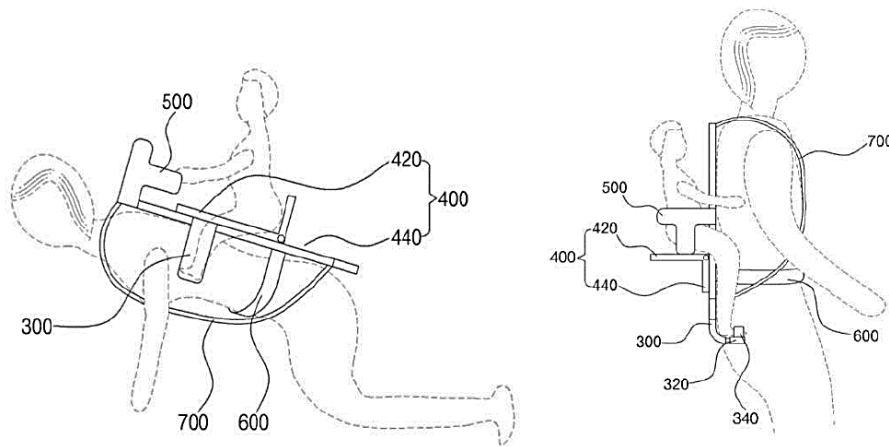

- **Baby carrier** that can be transformed into a wooden **horse rider toy**

\*The early prototype was made of wood by the client (inventor)



# Case Studies and Analysis

## Design Project 2: a Multi-functional baby carrier

- Expressive stance
- Receptive stance

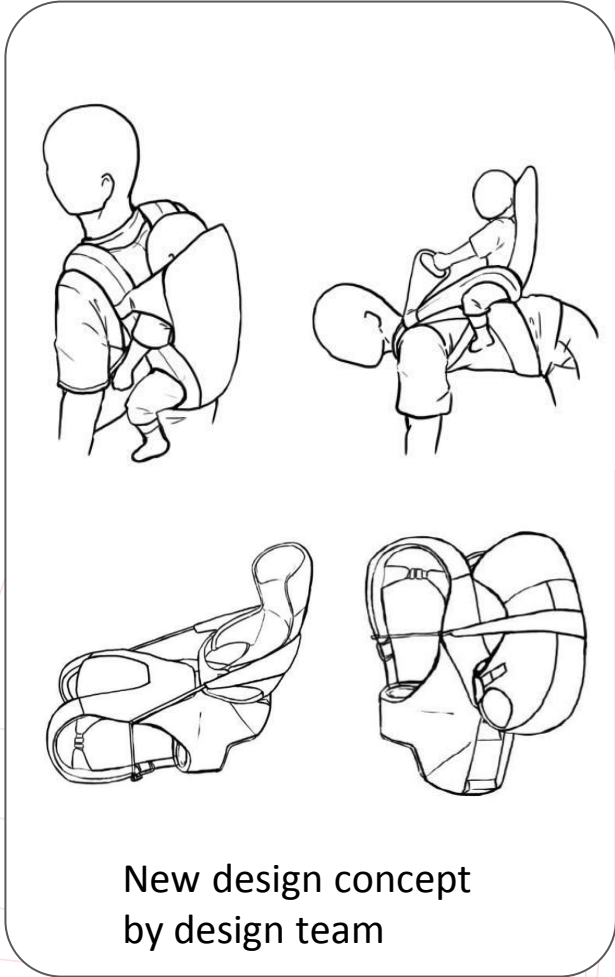
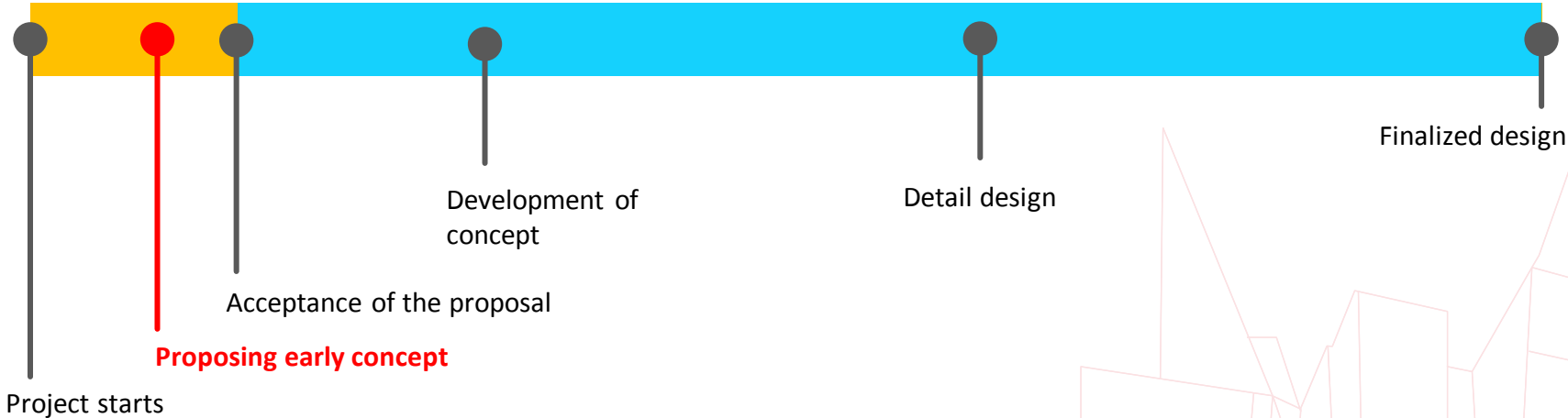

Early structure was naive as a commercial product:  
Design team proposed new design concept (more comfort, safe, easy to use)

► Client initially responded negatively (**Expressive stance**)

# Case Studies and Analysis

## Design Project 2: a Multi-functional baby carrier

- Expressive stance
- Receptive stance

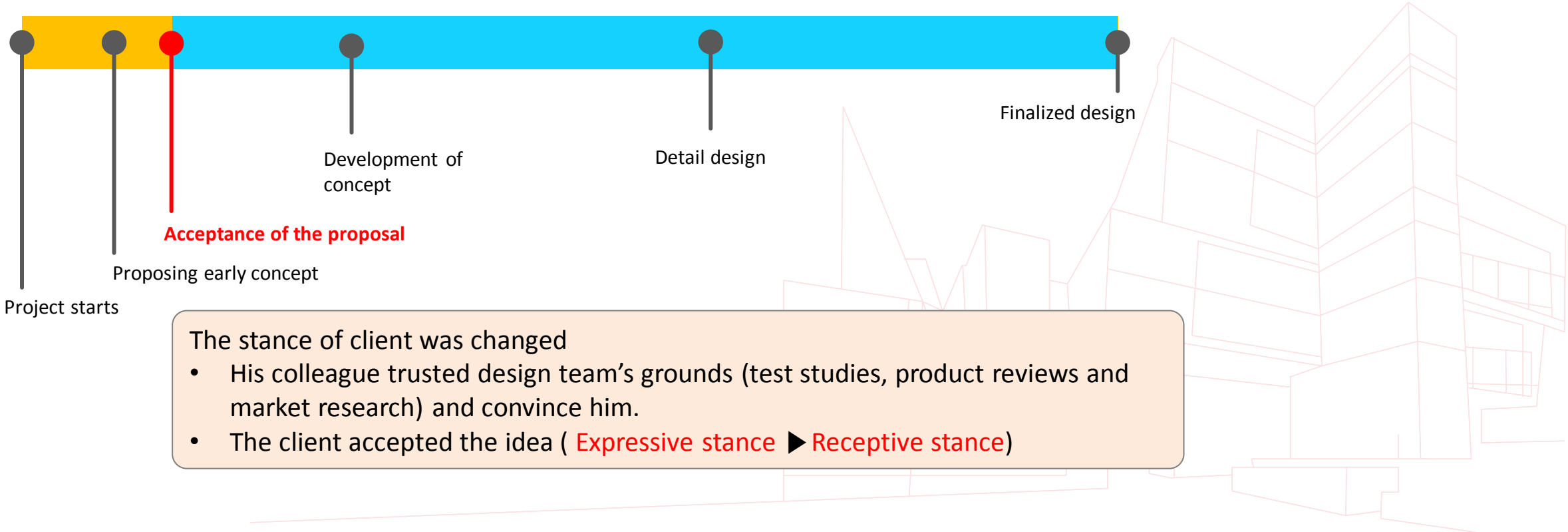

# Case Studies and Analysis

## Design Project 2: a Multi-functional baby carrier

- Expressive stance
- Receptive stance

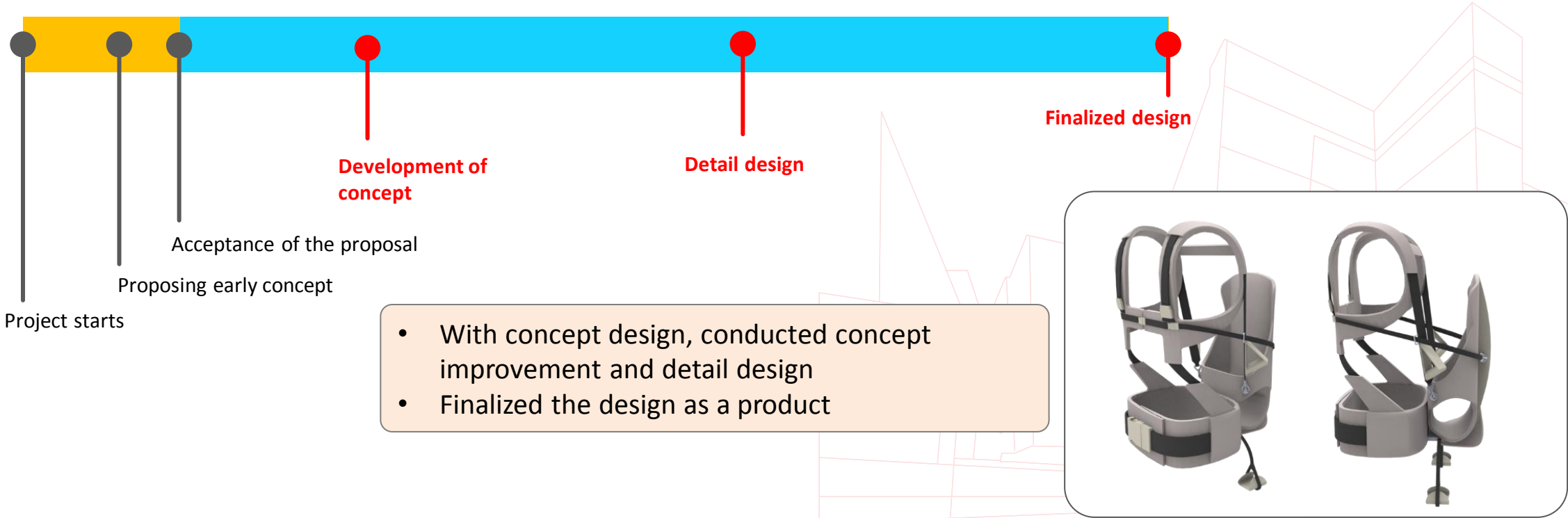

# Case Studies and Analysis

## Design Project 2: a Multi-functional baby carrier

- Expressive stance
- Receptive stance

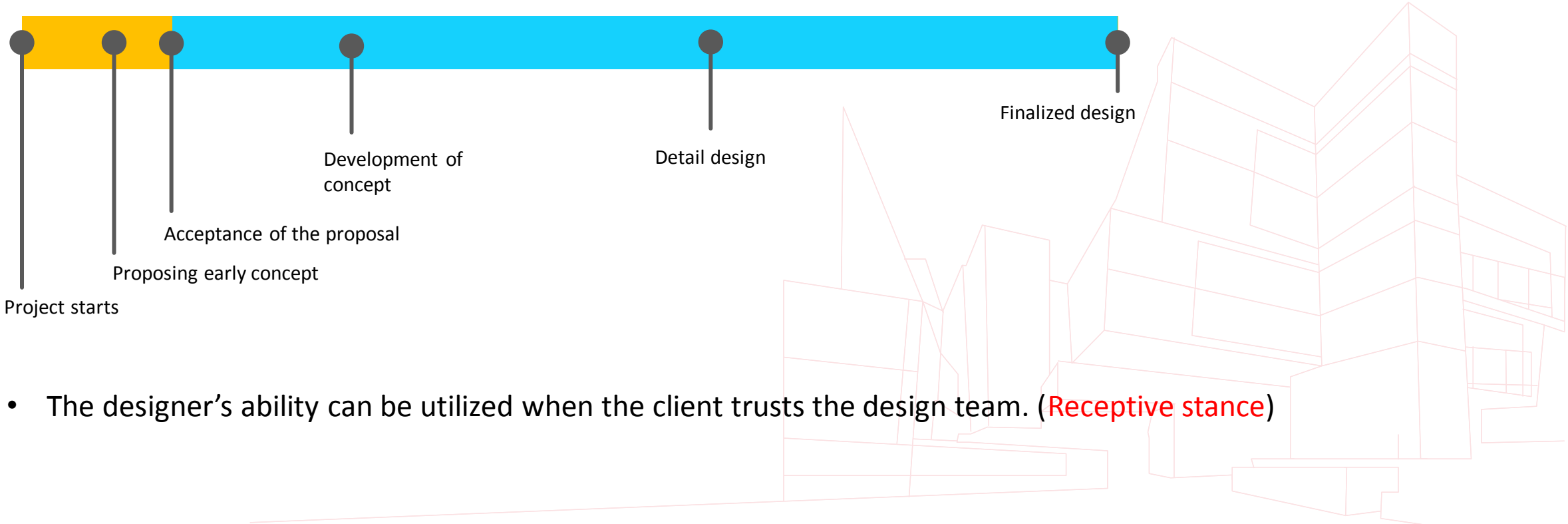

- The designer’s ability can be utilized when the client trusts the design team. (Receptive stance)

# Case Studies and Analysis

## Design Project 3: A radiation shielding Garment

- **Client's request**

**“Design a Radiation shielding garment”**

- Product design based on the client's patent



- Developed new radiation shielding garment for **nuclear power plants' workers**
- Used the shielding materials that the client developed, Flexible, easy to fabricate, high shielding performance against radiation



# Case Studies and Analysis

## Design Project 3: A radiation shielding Garment

- Expressive stance
- Receptive stance

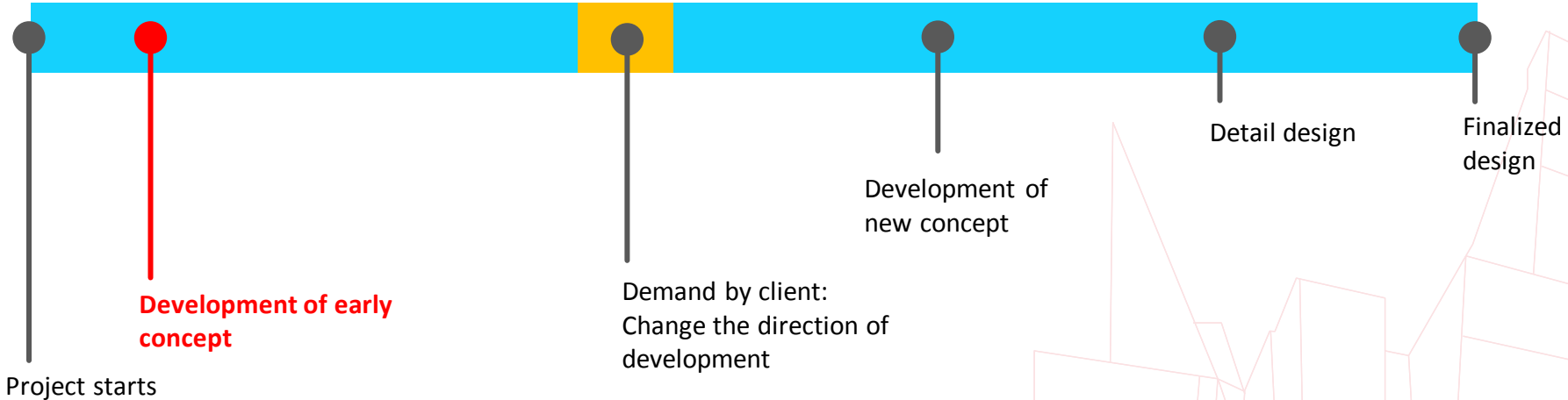

- Developed concept of shielding garments
- Module design: increased usability and cost effectiveness
- Wear a higher level module depending on the radiation dose

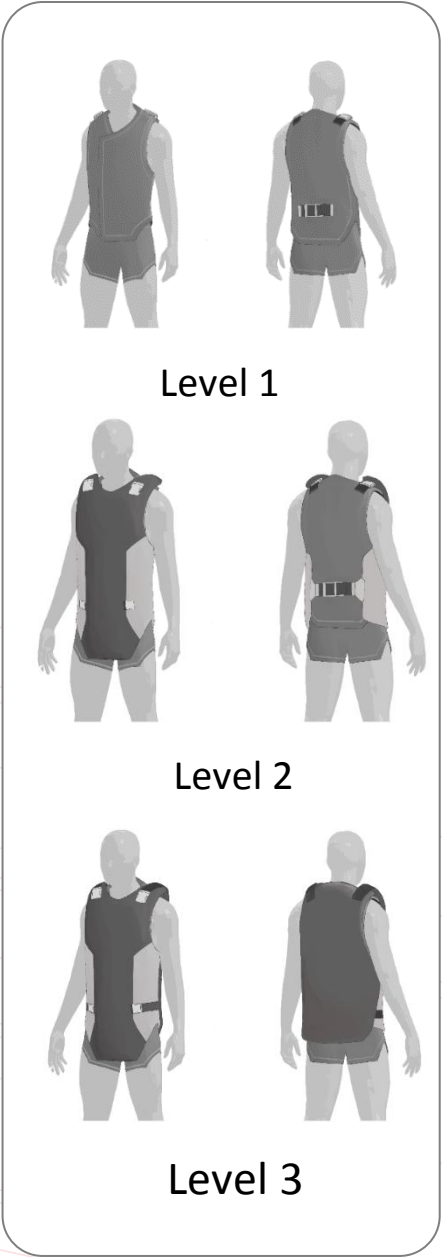

# Case Studies and Analysis

## Design Project 3: A radiation shielding Garment

- Expressive stance
- Receptive stance

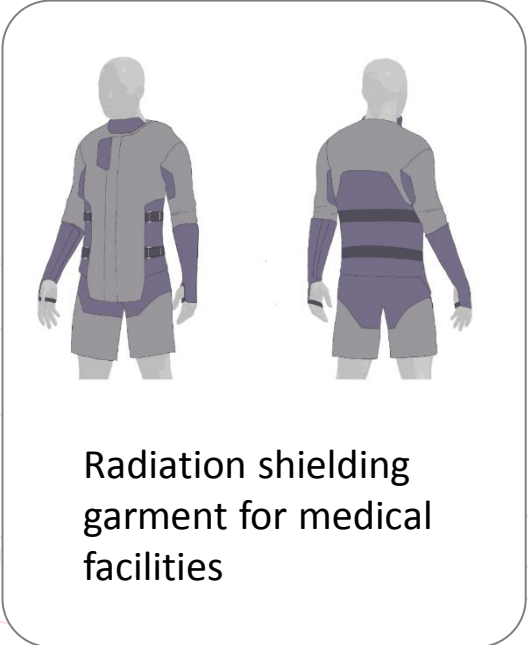
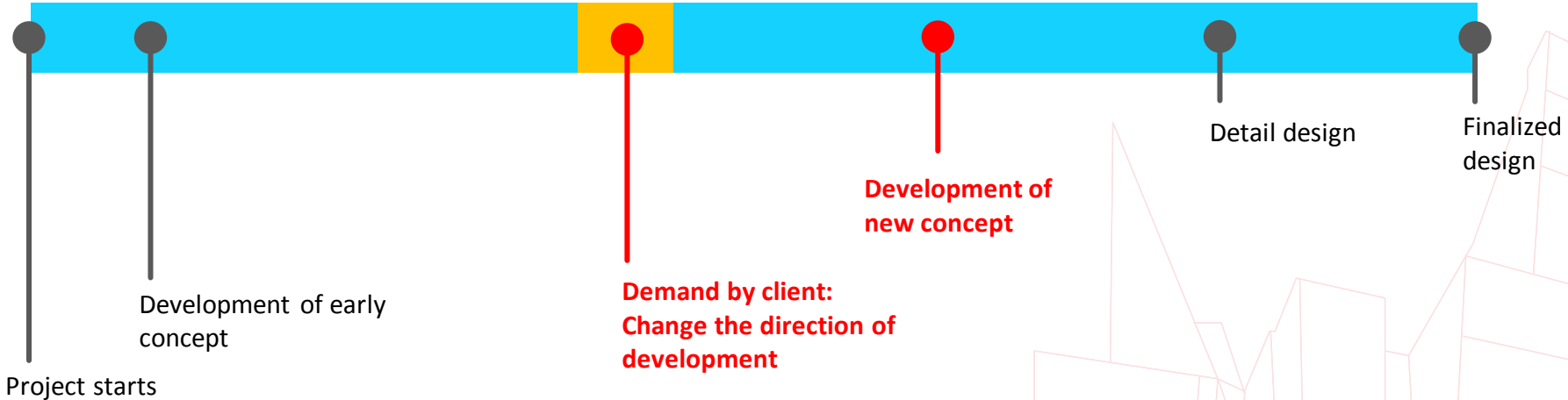

- Client requested for changes in design direction : to develop medical equipment (**Expressive stance**)
- Client acknowledged potential merit in medical equipment market

# Case Studies and Analysis

## Design Project 3: A radiation shielding Garment

- Expressive stance
- Receptive stance

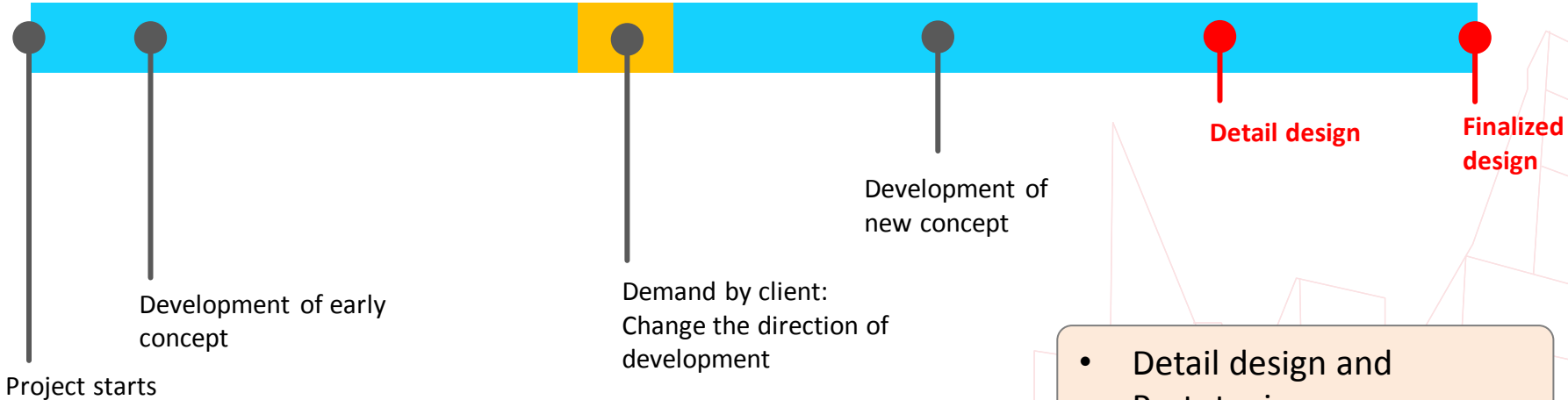

- Detail design and Prototyping
- Finalized design



# Case Studies and Analysis

## Design Project 3: A radiation shielding Garment

- Expressive stance
- Receptive stance

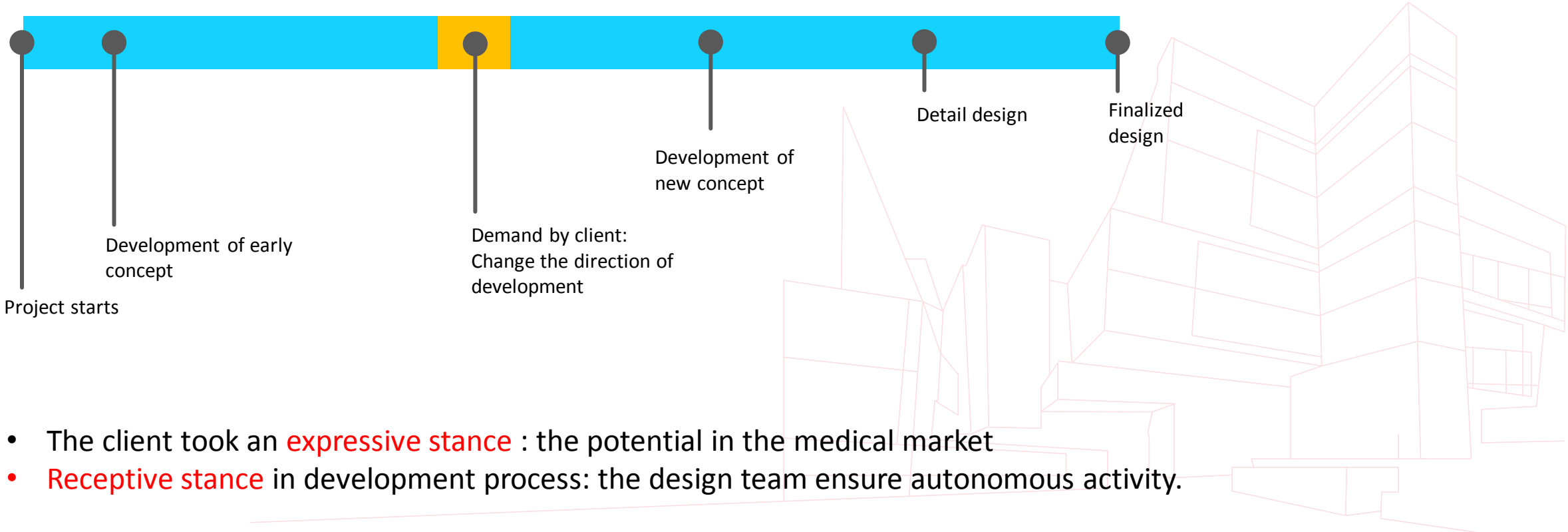

# Findings and Conclusions

Insights from the case studies

The effects of the client's stance

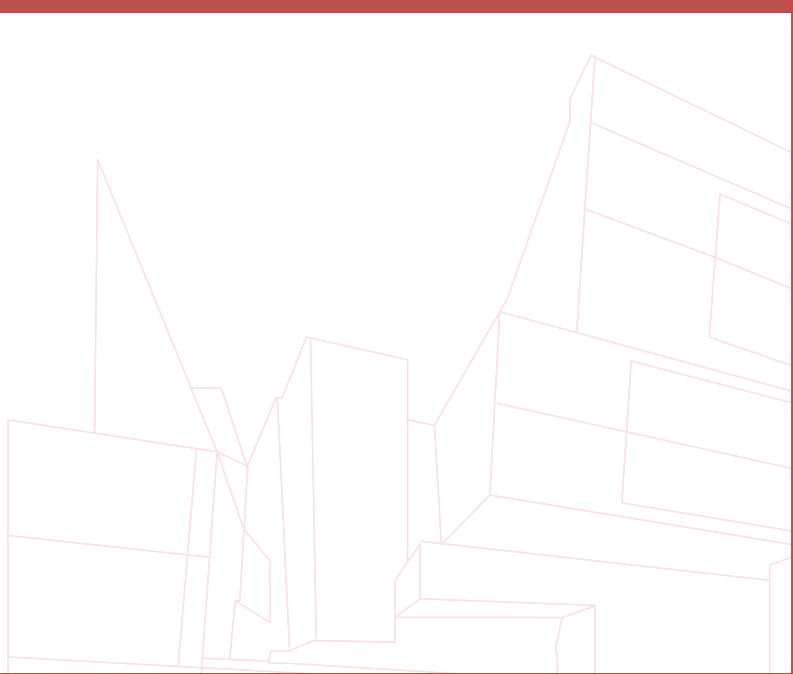
The expressive stance	The receptive stance
	

# Findings and Conclusions

Insights from the case studies

The effects of the client's stance

The expressive stance	The receptive stance
<ul style="list-style-type: none"><li>• Possibly limits the designer/team's capabilities (Case 1, chair)</li></ul>	

# Findings and Conclusions

Insights from the case studies

The effects of the client's stance

The expressive stance	The receptive stance
<ul style="list-style-type: none"><li>• Possibly limits the designer/team's capabilities (Case 1, chair)</li><li>• Reasonable intervention can lead to new design alternative/potential improvement (Case 3, shielding garment)</li></ul>	

# Findings and Conclusions

Insights from the case studies

The effects of the client's stance

The expressive stance	The receptive stance
<ul style="list-style-type: none"><li>• Possibly limits the designer/team's capabilities (Case 1, chair)</li><li>• Reasonable intervention can lead to new design alternative/potential improvement (Case 3, shielding garment)</li><li>• Can be changed as receptive stance If the design team succeed in persuading</li></ul>	

# Findings and Conclusions

Insights from the case studies

The effects of the client's stance

The expressive stance	The receptive stance
<ul style="list-style-type: none"><li>• Possibly limits the designer/team's capabilities (Case 1, chair)</li><li>• Reasonable intervention can lead to new design alternative/potential improvement (Case 3, shielding garment)</li><li>• Can be changed as receptive stance If the design team succeed in persuading</li></ul>	<ul style="list-style-type: none"><li>• Design team can sufficiently exhibit their capabilities.(Case2 baby carrier and 3)</li></ul>

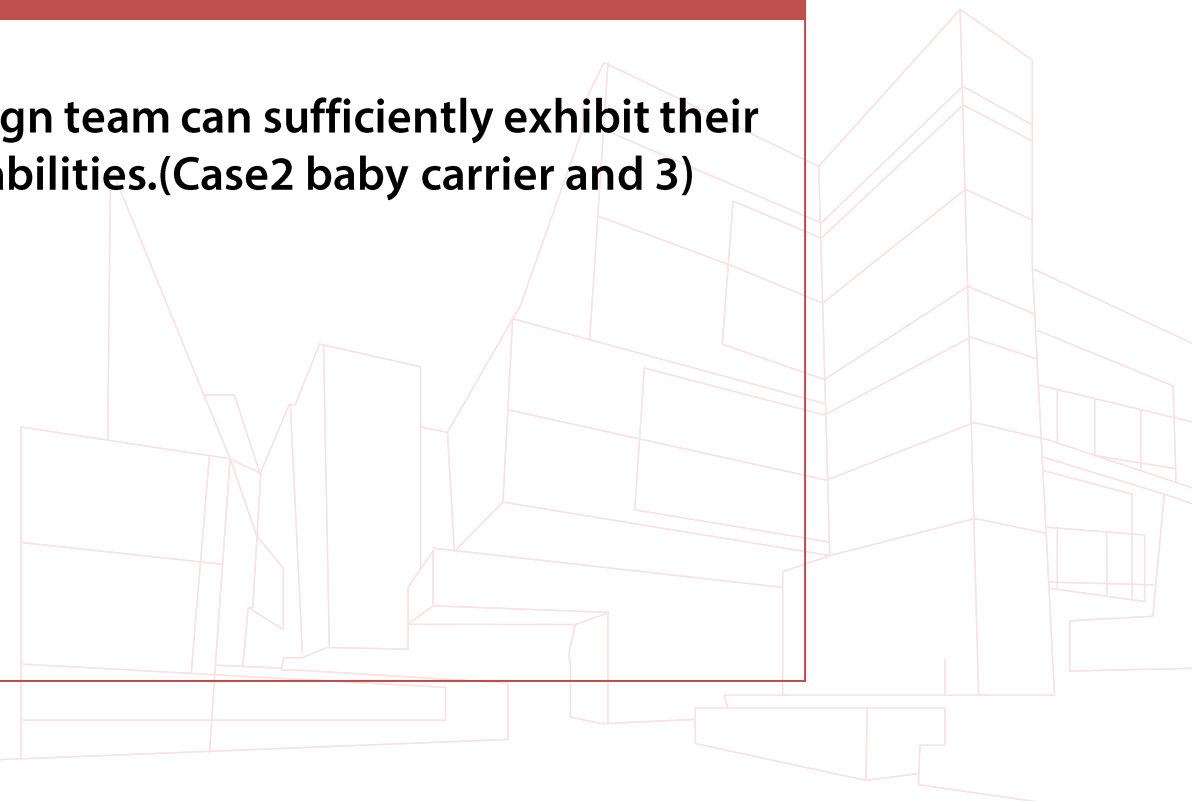

# Findings and Conclusions

Insights from the case studies

The effects of the client's stance

The expressive stance	The receptive stance
<ul style="list-style-type: none"><li>• Possibly limits the designer/team's capabilities (Case 1, chair)</li><li>• Reasonable intervention can lead to new design alternative/potential improvement (Case 3, shielding garment)</li><li>• Can be changed as receptive stance If the design team succeed in persuading</li></ul>	<ul style="list-style-type: none"><li>• Design team can sufficiently exhibit their capabilities.(Case2 baby carrier and 3)</li><li>• The direction of the product development that the designer thinks and the direction that the client wants possibly be different</li></ul>

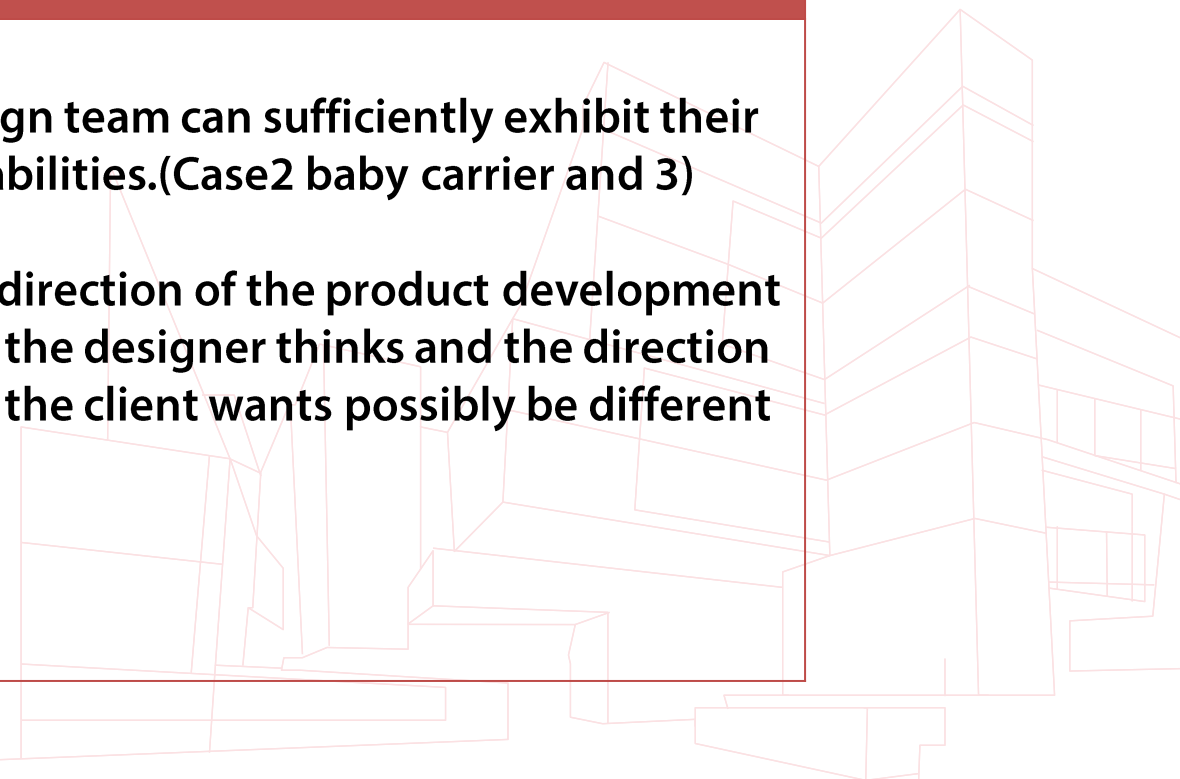

# Discussion

## Issues and Further study

- **Identifies a joint collaboration between SMEs and design team**
  - For a company that has design competence, the relationship can be different
- **Focuses on the relationship between clients and the design team**
  - Any relationship between a superiors and design team in a product development
  - Interactions between a number of teams in product development projects
- **How to convince the client? (expressive stance to receptive stance)**

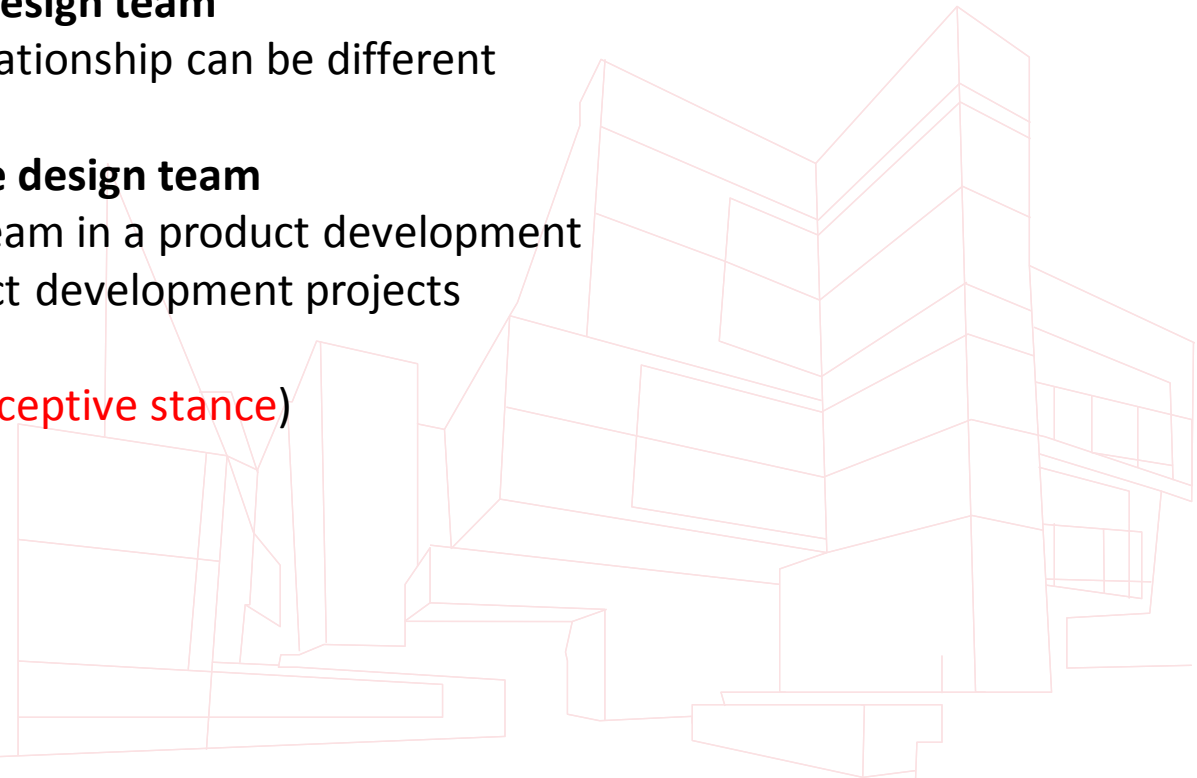

# Thank you!

geamongc@unist.ac.kr

