

# Window Storm Protector

A Baccalaureate thesis submitted to the  
Department of Mechanical and Materials Engineering  
College of Engineering and Applied Science  
University of Cincinnati

in partial fulfillment of the  
requirements for the degree of

Bachelor of Science

in Mechanical Engineering Technology

by

Luke Kimmel

May 2019

Thesis Advisor:

Professor Moise Cummings

# Table of Contents

|                                  |    |
|----------------------------------|----|
| Problem Statement.....           | 3  |
| Research.....                    | 4  |
| Background of the Problem.....   | 4  |
| State of the Art.....            | 4  |
| End User.....                    | 5  |
| Summary of Research.....         | 5  |
| Conclusion of Research.....      | 6  |
| Quality Function Deployment..... | 7  |
| Customer Features.....           | 7  |
| Engineering Characteristics..... | 8  |
| Concept Drawings.....            | 9  |
| Concept 1.....                   | 9  |
| Concept 2.....                   | 10 |
| Concept 3.....                   | 11 |
| Concept Selection.....           | 12 |
| Load Conditions.....             | 13 |
| Fabrication.....                 | 14 |
| Proof of Testing.....            | 15 |
| Calculations.....                | 16 |
| Testing Results.....             | 17 |
| FEA.....                         | 18 |
| BOM.....                         | 19 |
| Budget.....                      | 19 |
| Factor of Safety.....            | 20 |
| Material Selection.....          | 20 |
| Our Design.....                  | 21 |
| Conclusion.....                  | 22 |
| References.....                  | 23 |
| Appendices.....                  | 24 |
| Survey.....                      | 24 |
| Interview.....                   | 28 |

## **Problem Statement**

Protecting your home or business should be one of your top concerns. Especially against some of the extreme weather conditions that people see every year. In the event of a storm you have to worry about two main things, wind and rain. During a severe storm any object on the ground can be picked up by the wind and thrown at your property (flying projectiles). If they were to hit your house in at the weakest points, which is usually your windows, the elements of the storm could get in and destroy the content. As well as, tear the structure apart from the inside out. We want to design a new shutter system that is rated for extreme winds and can withstand projectiles hitting it at high speeds.

Currently on the market most houses have shutters, but nearly all of the shutters on houses these days are purely for decoration. Shutters that do work as they are intended are almost always wood and can only protect your window from weaker storms. Also, the process of getting your shutters closed is long and time consuming. There are roll down shutters, but they only protect from wind and rain due to the material being flexible.

Another important factor to our design will be the locking mechanism. With our research we were able to determine that a lot of the designs on the market failed to have a good locking mechanism to keep the window protection stable during a storm. We will create a heavy duty lock that is able to withstand all the elements of a severe storm. The lock will to be easy to access and will be incorporated into the structure to give it a nice clean look.

We are proposing making a product that will be faster and easier to implement on a window, and more durable than wood shutters. We want the device to be in the frame of the house, and it to look very elegant and not be an eye sore on the house. The device will be up to Florida house codes.

# Research

## Background of the Problem

Storm shutters are commonly used in homes, warehouses, businesses and lots of other structures that require window protection. Over time there have been a couple different designs that have been made to keep up with the standards of modern housing (4). Shutters can fit within the window opening or hang outside and overlap the opening. The simple wood shutter design does an acceptable job of blocking out the wind and rain, but when it comes to severe storms with heavy winds it is more desirable to stop flying projectiles from breaking through the window (3). The danger lies when a window breaks during a high-powered storm, the new opening will act like a balloon opening and massive amounts of air will rush in your house. The increasing pressure inside the house could cause the roof to come off. So, if one window breaks, not only is there a risk of water damage, the house structure loses its integrity.

Addressing an issue for home and business owners is something that is very important and that needs to be dealt with. With the increase in hurricanes over that last couple of years there are going to be new customers looking for affordable and reliable window storm protection. One main problem that was brought to our attention were the amount of time it takes to prepare your window protection before a storm. The current average time for set-up is around 15 minutes per window. When there is a severe storm they might not have enough time to get all of their protection systems set-up. In the industry there are a few automatic shutters, but they are made from weaker material and only protect from rain and minimal wind. Also, the cost for these shutters can go as high as \$75 per square foot.

## State of the Art

The main problem that we are looking to address is coming up with a stronger material and develop a way to decrease the set-up time. (1). Features that need to be looked at for the design aspects are trying to improve the strength of the shutter system comparable to wood shutters. The material that we select must have a high impact strength and something elegant that will go along with the house. Some concerns we have are the weight, cost, and durability. Materials that are currently being used for window protection systems are Polycarbonate, Aluminum, Plywood, nylon, Plastic, and Steel (2). Aluminum is the most common material used, because of its strength, lower cost, and it is easier to manufacture. Plywood is used as a last-minute preparation in most cases. It is cheaper to use but it does not work well with severe storms and it isn't a long-term option. There are several different designs that are currently on the market, none that use smart technology. (Picture 1) shows a door hinge wood shutter design that works for minor storms. This design will help protect your windows with smaller storms with low wind speeds, but with a severe storm the high winds will throw projectiles. In this case the wood isn't strong enough to protect the windows (5). (Picture 2) This is an example of an aluminum roll down shutter. This design is one of the best that is currently on the market because it is easy to install, and it is easy to operate. The roll down protection system is operated by a control switch or remote function. The only issue with the roll down protection system is that it has a thin wall of material due to it having to roll up into a small housing above the window. Again, this raises concerns for high wind speeds and if it is strong enough to protect the window (5). (Picture 3) This is a temporary solution for window protection system but is the easiest to install/setup. This

shutter system uses an accordion type method with plastic material to cover the window. They use locking features to keep the system stable and attached to the housing. Once again, this design has heavy concerns with its integrity on high winds. The material works very well against rain but can fracture easily with flying projectiles (5). Our plan to use a high strength galvanized steel, this will eliminate our concern of durability. Steel will also allow the option to customize the shutters to fit a customer's property. We are also going to be coming up with a plan b solution to our system. This will allow you the option of operating the window protection system manually if there is some sort of technology problem or power outage.

### **End User**

The Specific End user we plan on targeting are people with homes along the coast and people in Tornado Valley. The end user would want this product to protect their homes and have the ease of open and closing the system quickly and efficiently.

### **Summary of Research**

- A single window replacement can cost around \$700.
- When the window breaks it could cost around \$18 per square foot for repairs for water damage.
- For a house of 2,000 square feet this cost could be upwards of \$35,000.
- Average storm Panel Hurricane Shutters take 15 min. to set up per window.
- No current product on the market uses steel plates for a permanent setup.

## Conclusion of Research

We learned from our research that even during the course of Hurricane Florence people are still worried about protecting their homes and windows and doors will be damaged. This shows Bryan and I that there is room to improve on window protection. The research also showed that our idea to make shutters more durable and easier to operate will help decrease the response time before a storm. We are confident this project is worthwhile and there would be a place on the market for them.

(Figure 1) – Basic wood shutter design good for light wind and rain

(Figure 2) – Roll shutters that are great for heavy rains but have a thin weak material that could break with severe winds and hard impacts

(Figure 3) – Plastic slide shutters that are good for light storms but can break easily with heavy impacts



Figure 1

### Colonial Shutters

- Average cost \$28-\$40 per square foot
- Average setup time is 10 to 15 minutes per window
- Rated Impact level =  $\leq$  Missile Level B



Figure 2

### Roll-Down Shutters

- Average cost \$30-\$65 per square foot
- Average setup time is 1 to 2 minutes per window
- Rated Impact level =  $\leq$  Missile Level C



Figure 3

### Accordion Shutters

- Average cost \$16-\$20 per square foot
- Average setup time is 10 to 15 minutes per window
- Rated Impact level =  $\leq$  Missile Level B

## Quality Function Deployment

Customer Features – Ranked from most to least important

| Demanded Quality       |                   |
|------------------------|-------------------|
| Customer Features      | Importance Weight |
| Durability             | 30%               |
| Closes Easily          | 15%               |
| Opens Easily           | 15%               |
| Locking Feature        | 10%               |
| Meets House Codes      | 10%               |
| Remote Function        | 5%                |
| Elegant Look           | 5%                |
| Different Size Windows | 5%                |
| Reasonable Weight      | 2.50%             |
| Easy Installation      | 2.50%             |
| Total                  | 100%              |

Figure 4

## Engineering Characteristics - Ranked from most to least important

| Quality Characteristics |                   |       |
|-------------------------|-------------------|-------|
| Functional Requirements | Importance Weight | %     |
| Material Selection      | 405               | 12.70 |
| Force Required to Close | 340               | 10.66 |
| Strength                | 340               | 10.66 |
| Force Required to Open  | 340               | 10.66 |
| Safety                  | 265               | 8.31  |
| Size                    | 255               | 7.99  |
| Easy to Lock            | 240               | 7.52  |
| Easy to Maintain        | 235               | 7.37  |
| Weight                  | 215               | 6.74  |
| Easy to Setup           | 210               | 6.58  |
| Device Cotrolled        | 175               | 5.49  |
| Slides                  | 170               | 5.33  |

Figure 5

### Final Product Objectives

- Design a durable and long-lasting window protection system
- Design a way to make it easy to operate (open and close)
- Design a locking mechanism so the protection stays in front of the window
- Meet Florida house codes and specifications
- Design a permanent system that requires less than 15 minutes set up during a severe storm

## Concepts Drawings

Concept 1:

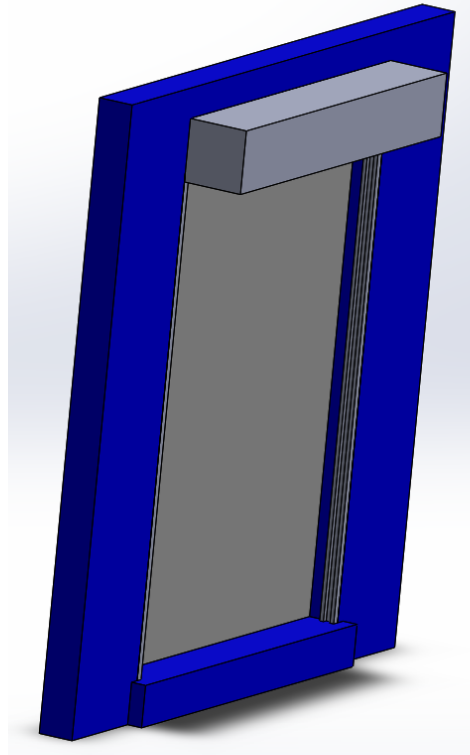
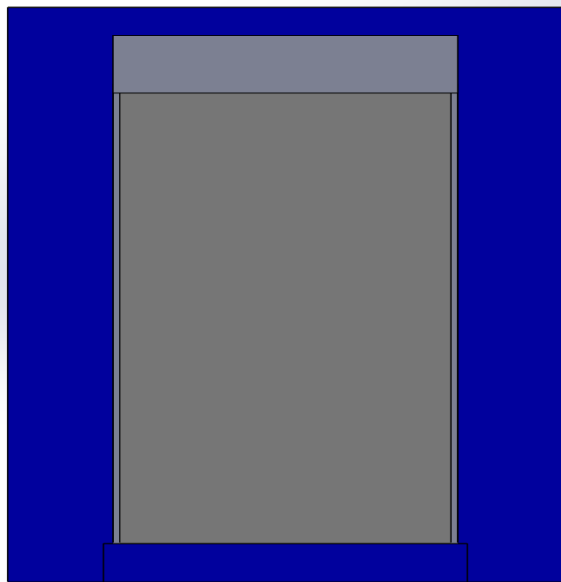

### Pros

- Compact Design
- No storage required
- Rails on the Vertical sides of the windows
- Looks natural on the house

### Cons

- Thin Material
- Lower Strength
- Hard to Repair
- Higher Cost per Window

Concept 2:

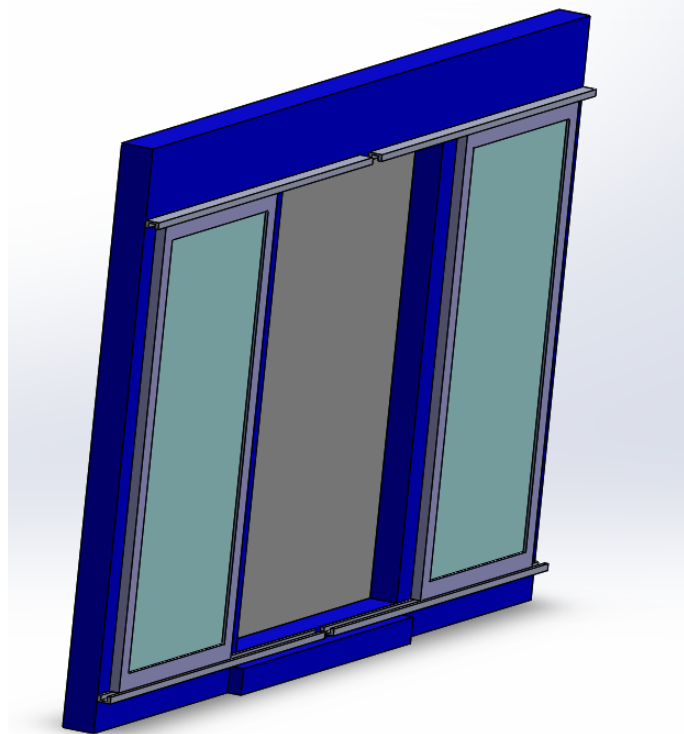
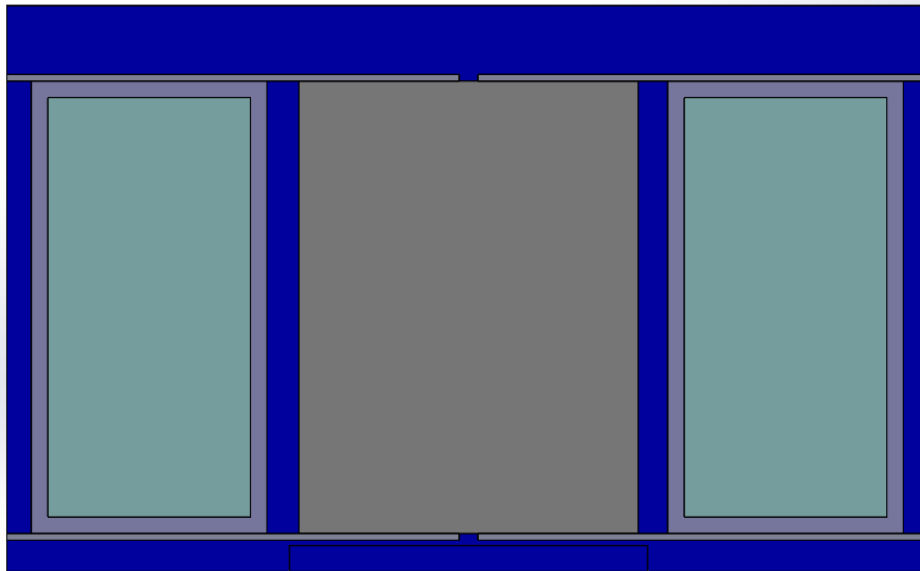

## Pros

- Locking Mechanism
- No storage required
- Easy to open and close
- Higher Strength

## Cons

- High Weight
- Bulky look on house
- Rails on the Horizontal sides of the windows

Concept 3:

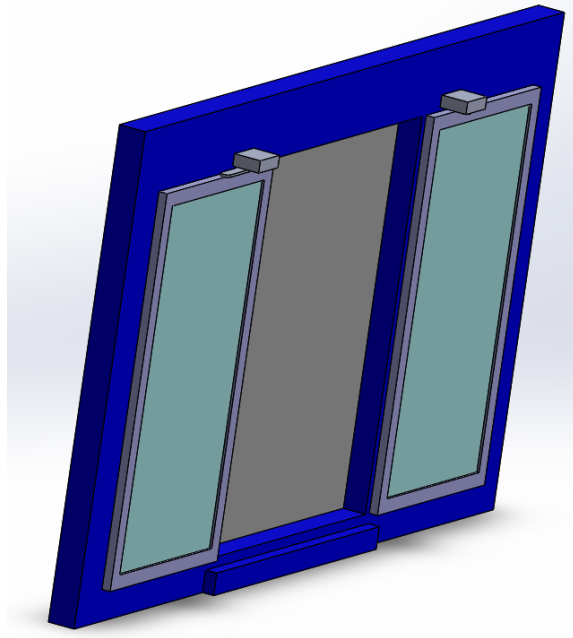
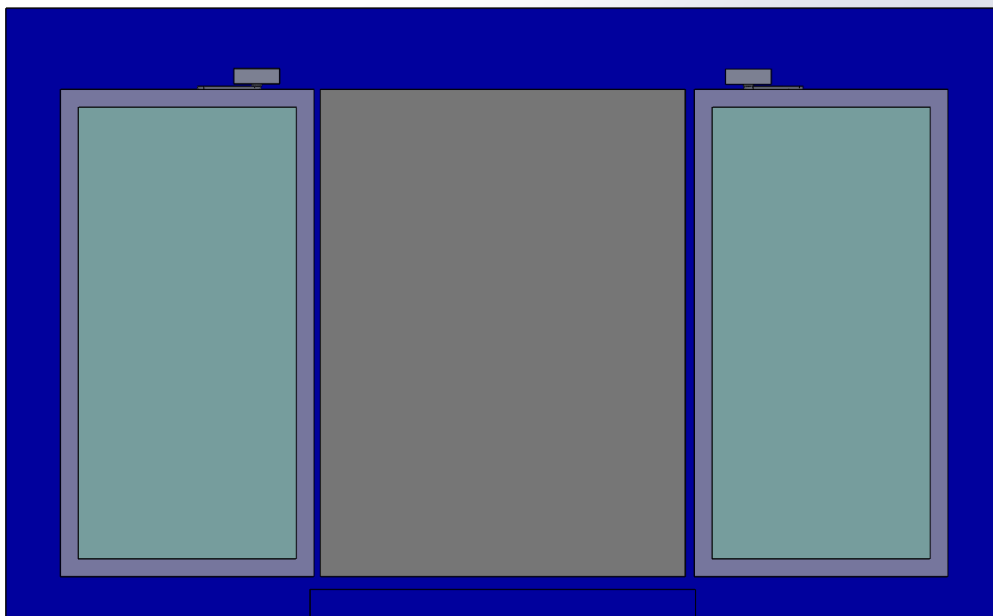

### Pros

- No storage required
- Easy to open and close
- High Strength
- Looks natural on the house

### Cons

- No locking mechanism
- High Weight
- Higher cost per window

**Concept Selection:**

| <b>Product Objectives Selection</b>                                |                  |                  |                  |
|--|------------------|------------------|------------------|
| <b>Customer Features</b>   | <b>Concept 1</b> | <b>Concept 2</b> | <b>Concept 3</b> |
| <b>Easy to Open</b>  | 7                | 8                | 7                |
| <b>Easy to Close</b>   | 7                | 8                | 7                |
| <b>Locking Feature</b>   | 7                | 8                | 5                |
| <b>Looks Good on house</b>   | 8                | 6                | 8                |
| <b>Easy to maintain</b>  | 4                | 7                | 7                |
| <b>Cost</b>  | 5                | 7                | 6                |
| <b>Durability</b>  | 7                | 8                | 7                |
| <b>Total</b>   | <b>45</b>        | <b>52</b>        | <b>47</b>        |
| <b>The Scale is 1-10. 10 being the best and 1 being the worst.</b> |                  |                  |                  |

*Figure 6*

## Load Conditions: For Impact

- Large Missile Impact Test
- 2 x 4 x 8ft
- Must impact at least 2 locations on the shutter system (middle and corner)
- Missile must be traveling at least 50 f/s or 34 mph.
- The missile cannot pierce the shutter system and the maximum deflection of the shutter must be no more than the height of the shutter divided by 30

Example:

Height =40”

Deflection= 0.5”

$$\frac{H}{30} = \frac{40}{30} = 1.33" = PASS$$

## **Fabrication:**

- Hole Tapping
  - Wheel mounting holes
- CNC Plasma Cutting
  - Steel Plates
- Drill Press
  - Rail System
- Hand Drill
  - Window Frame/Testing Frame
- Cold Saw/Wood Saw/Band Saw
  - Rail System
  - Window Frame/Testing Frame
  - Brackets
- Grinding/Cutting
  - Brackets
  - Rail System
  - Steel Plates

# Proof of Testing – ASTM E – 1996 Standard











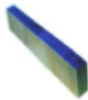



|   |  | Large Missile (● Impact Location)  |  |   |  |
|---|--|--|--|---|--|
| <br>Missile<br><br>2" X 4" Lumber          | Level B 2lb @ 50 f/s<br>Level C 4.5lb @ 50 f/s<br>Level D 9lb @ 50 f/s<br>Level E 9lb @ 50 f/s |   |   |   | <b>Pass/Fail</b><br>• No Tear Permitting a 3" Sphere to Pass Through<br>• No Tear Longer than 5" |
|   | TAS 201 (HVHZ) 9lb @ 50 f/s  |   |   |   | <b>Pass/Fail</b><br>• No Tear Longer than 5" and 1/16" in Width                                  |
|   |  | Small Missile (● Impact Location)  |  |   |  |
| <br>Missile<br><br>(10) 2 Gram Steel Balls | ASTM E-1996 2g @ 130 f/s   |   |   |   | <b>Pass/Fail</b><br>• No Tear Permitting a 3" Sphere to Pass Through<br>• No Tear Longer than 5" |
|   | TAS 201 (HVHZ) 2g @ 130 f/s  |  |  |  | <b>Pass/Fail</b><br>• No Tear Longer than 5" and 1/16" in Width                                  |

Figure 7 High Missile Impact Test Procedure

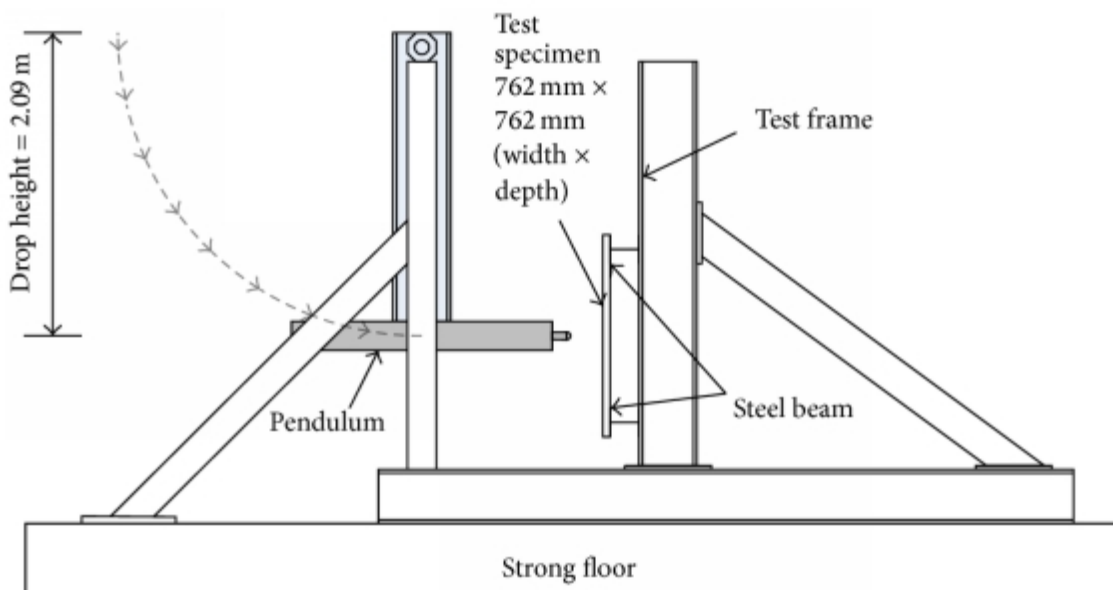
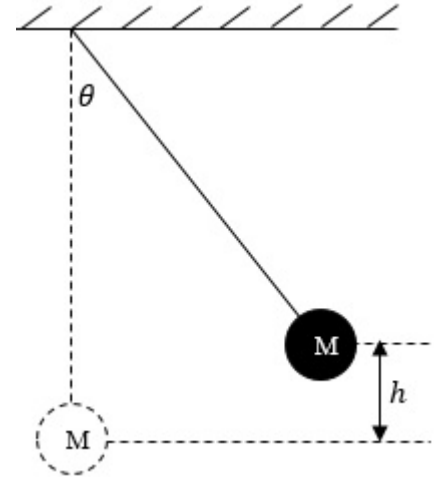

Figure 8 Charpy Impact Test

## Acceleration of Pendulum

- $mgh = \frac{1}{2}vm^2$ 
  - $gh = \frac{1}{2}vm$
  - .762 length of pendulum
  - $.762(1 - \cos(85)) = 1.512$
  - $2gh = 2(9.81)(1.512) = 29.66$
  - $v^2 = 29.66$
  - $v = 5.44m/sec$



## Force Acting on Plate

- $F = \left(\frac{0.5*m*v^2}{d}\right)$
- $F = \left(\frac{0.5*38.55kg*5.44^2}{0.006mm}\right)$
- $F = 95,069N$  or  $F = 95.07kN$

## Impact Results

| Zone        | Wind Speed                              | Missile Level |
|-------------|---|---------------|
| Wind Zone 1 | 110 mph ≤ Basic wind speed<br>< 120 mph | A             |
| Wind Zone 2 | 120 mph ≤ Basic wind speed<br>< 130 mph | B             |
| Wind Zone 3 | 130 mph ≤ Basic wind speed<br>< 140 mph | C             |
| Wind Zone 4 | Basic wind speed > 140 mph              | D             |

*Testing 1 Wind Speed Related to Missile Level*

| Level | Material   | Weight  | ft/sec     | Impact Force |
|-------|------------|---------|------------|--------------|
| A     | metal      | 2 grams | 130 ft/sec | 0.314kN      |
| B     | wood (2x4) | 2 lbs   | 50 ft/sec  | 21.07kN      |
| C     | wood (2x4) | 4.5 lbs | 40 ft/sec  | 30.34kN      |
| D     | wood (2x4) | 9lbs    | 50 ft/sec  | 94.82kN      |
| E     | wood (2x4) | 9lbs    | 80 ft/sec  | 240.727kN    |

*Testing 2 High Missile Impact Test Procedure*

| Test Method        | Missile Level | Material   | Weight  | ft/sec       | Force     | Deflection | Test Pass/Fail |
|--------------------|---------------|------------|---------|--------------|-----------|------------|----------------|
| BB Gun             | A             | metal      | 2 grams | 130 ft/sec   | 0.314 kN  | None       | Pass           |
| Charpy Impact Test | B             | wood (2x4) | 20 lbs  | 17.85 ft/sec | 22.36 kN  | None       | Pass           |
| Charpy Impact Test | C             | wood (2x4) | 28 lbs  | 17.85 ft/sec | 31.329 kN | None       | Pass           |
| Charpy Impact Test | D             | wood (2x4) | 85lbs   | 17.85 ft/sec | 95.106 kN | None       | Pass           |
| Charpy Impact Test | E             | wood (2x4) | 215 lbs | 17.85 ft/sec | 240.45 kN | -----      | Not Tested     |

*Testing 3 Results After Performing the Charpy Impact Test Procedure*

The window protection system was tested using the Charpy test method to mimic the high missile impact testing required in the ASTM E 1996 specification. This test is used to measure the amount of deflection the protection system encounters when it is impacted at different speeds and weights. For our testing procedure we calculated the different weights we would need to use to represent the test requirements listed in the ASTM spec. We released the weights at a 90 degree angle and performed testing in the middle of the plates and the top right corner of the plates. Our system passed the required testing and showed no permanent deformation for any of the tests conducted.

# FEA Analysis

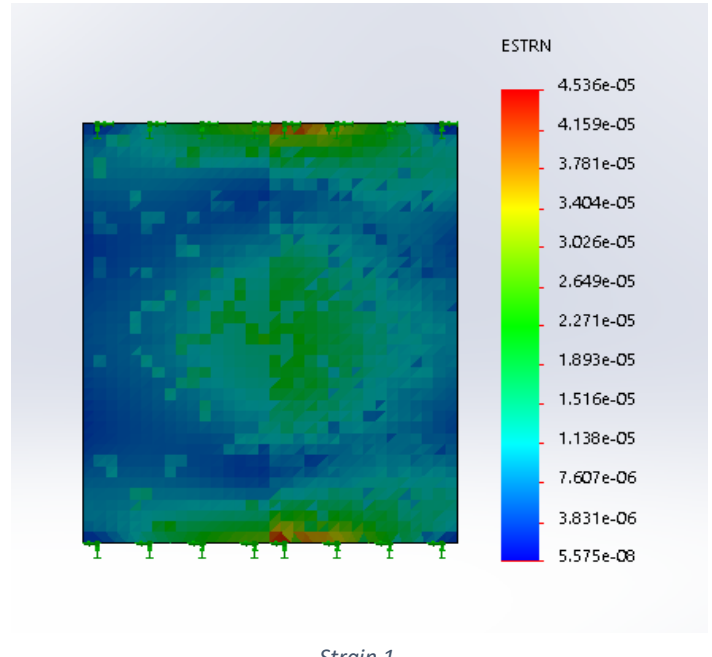
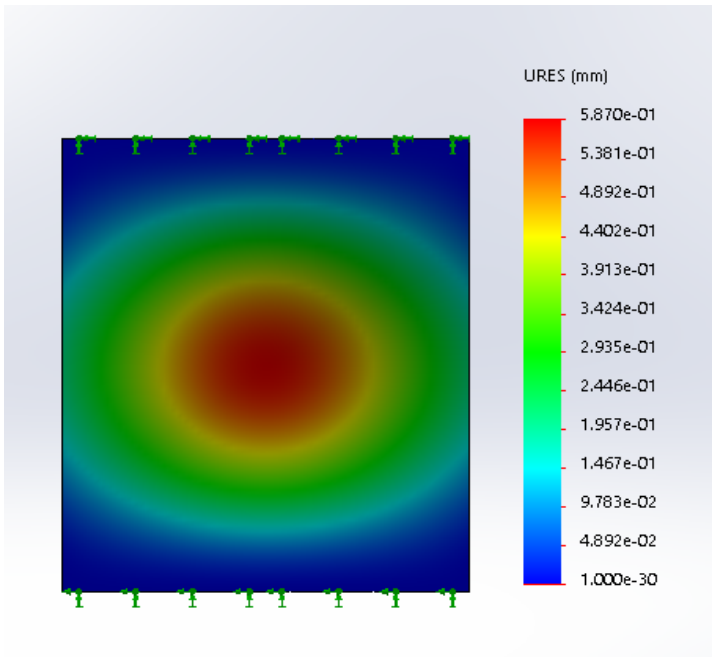
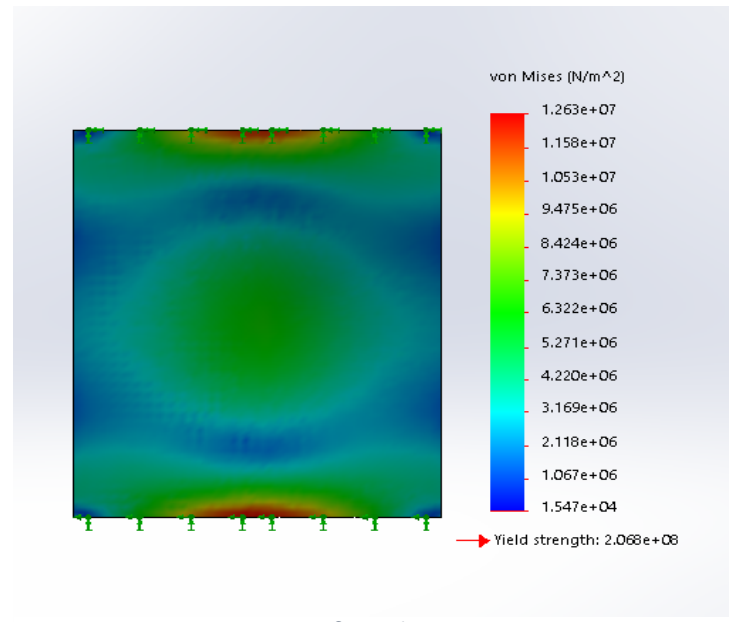
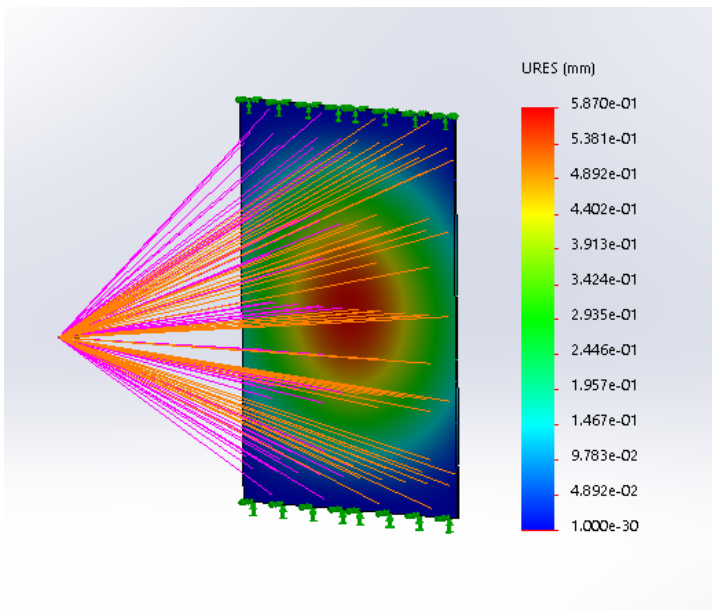

## BOM

|                            | Count | Price/Piece | Total Price     |
|----------------------------|-------|-------------|-----------------|
| <b>Window Protector</b>    | 1     |             | <b>\$255.73</b> |
| <b>Mechanical Assembly</b> | 1     | 1           | \$255.73        |
| Shutter (304 Alloy Steel)  | 2     | 75          | \$150           |
| Rails (Angle Iron)         | 4     | 12          | \$48            |
| Wheels                     | 10    | 1           | \$10            |
| Brackets                   | 7     | 2.39        | \$16.73         |
| Screws 3mm                 | 20    | 0.35        | \$7             |
| Wood Screws (box)          | 1     | 5           | \$5             |
| Impact Tape (roll)         | 1     | 19          | \$19            |

Figure 9

## Budget

| Item                              | Cost           |
|-----------------------------------|----------------|
| wheels                            | 7.34           |
| Pins                              | 1.05           |
| Tap                               | 6.41           |
| Tap and bit                       | 8.97           |
| glue, tape, paint, chain, s hooks | 29.84          |
| screws, wheel, bolt and nut       | 14.89          |
| tap tools                         | 11.75          |
| Bracket/Brace                     | 4.25           |
| Plate                             | 100            |
| poster                            | 22.64          |
| Deck Screws                       | 8.98           |
| Braces                            | 26.3           |
| Angle Iron                        | 63.88          |
| Rail Nuts and Bolts               | 22.3           |
| <b>Total</b>                      | <b>\$328.6</b> |

Figure 10

# Factor of Safety

Factor of safety of 12

-highly ductile

-high yield strength

## Factor of Safety (Safety Factor)

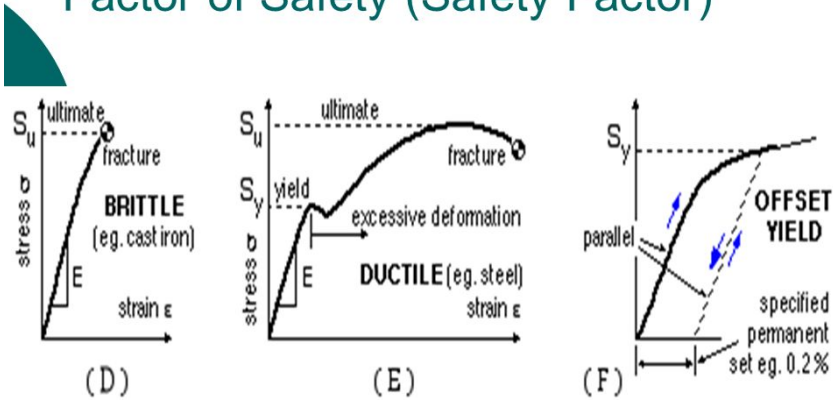

$$FoS = \frac{\text{Strength of the component } (S_u, S_y)}{\text{Stress in the component due to the actual load}}$$

Figure 11

## Material Selection

Shutter - 1/4" Alloy Steel 304

Rails – Everbilt Angle Iron 1/8" thick



## Our Design



Figure 12



Figure 13

## Doomsday Doors

- Average cost: \$20-\$25 per square foot
- Average storm preparation time: 1-2 minutes per window
- Rated Impact level =  $\leq$  Missile Level D

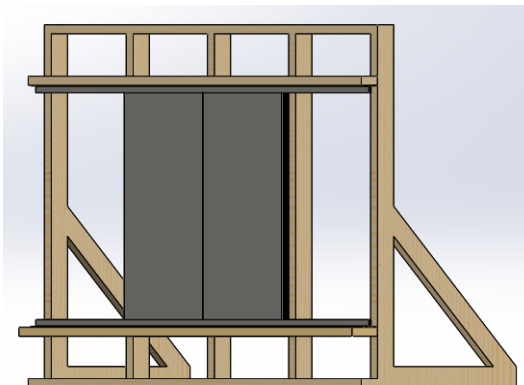

Figure 14

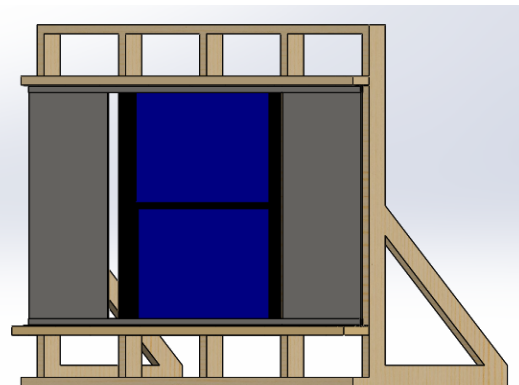

Figure 15

# Conclusion

## We met 92.5% of customer's criteria

- Very Durable – 30% - Passed – Passed Florida and ASTM specs
- Closes Easily – 15% - Passed – Open with one finger
- Opens Easily – 15% - Passed – Close with one finger
- Locking Feature – 10% - Passed – Easy to use locking pins
- Meets House Codes – 10% - Passed – Frame and protector meets Florida codes
- Remote Function – 5% - Failed – Impractical
- Elegant Look – 5% - Passed – Looks presentable.
- Fit for different size windows – 5% - Passed – just use different ratios
- Reasonable Weight – 2.5% - Failed- each plate weight roughly 53lbs

## References:

1. AGP. (2014, December 26). Affordable Glass Protection. Retrieved September 9, 2018, from [http://www.affordableshutters.com/products\\_storm.php](http://www.affordableshutters.com/products_storm.php)
2. Guide to Shutters. (2002, April 13). Everything you Need to Know. Retrieved September 9, 2018, from <http://www.guidetoshutters.com.au/page/2/AHistoryofShutters.html>
3. Layton, T. (2018, February 15). The Real Danger of Flying Debris. Retrieved September 9, 2018, from <https://www.popularmechanics.com/science/health/a9182/the-real-danger-of-flying-debris-in-a-hurricane-15648276/>
4. Miller, J. (2004, June 3). The History of Window Shutters. Retrieved September 9, 2018, from <http://www.allaboutshutters.com/shutter-history.htm>
5. Sun Sentinel (2017, September 6) Hurricane Shutter Guide: Compare Types. Retrieved September 6, 2017, <http://www.sun-sentinel.com/news/weather/hurricane/sfl-hc-shutterguide-htmlstory.html>

**Appendices**

## Survey Questions

For our survey questions we gave the following information and then asked for people to answer with a 1-5 scale. 1 being least important and 5 being most important to them.

This survey is for our Senior Design Project at school. Protecting your home or business should be one of your top concerns. Especially against some of the extreme weather conditions that people see every year. During a storm you have to worry about two main things, wind and rain. With a severe storm any object on the ground can be picked up by the wind and thrown at your property (flying projectiles). If they were to hit your house at the weakest points, which are usually your windows, the elements of the storm could get in and destroy the content. As well as, destroy the structure apart from the inside out. We are proposing making a product that will be faster and easier to implement on a window, and more durable than wood shutters. We want the device to be in the frame of the house, and to look very elegant so it's not an eye sore on the house. The device will be up to Florida house codes. If you could please review the questions and answer accordingly we would appreciate it.

The following graphs and questions are the responses from 26 individuals.

### Is weight an issue for your window protection?

26 responses

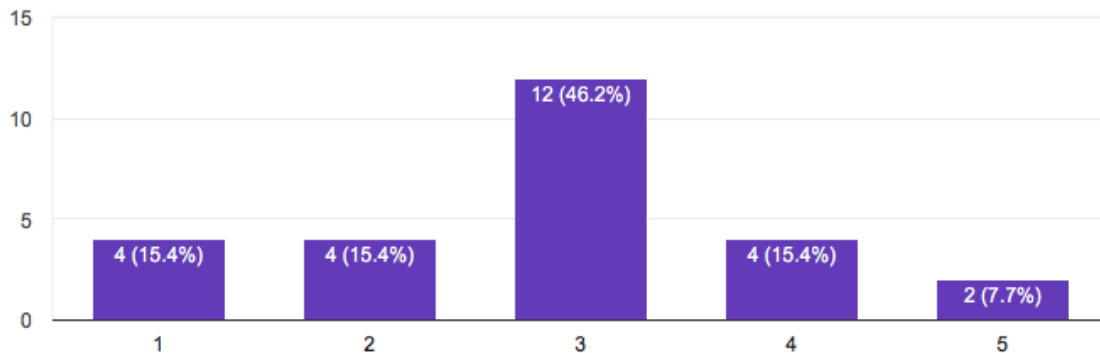

### Is too loud of noise from the Window Protector a factor?

26 responses

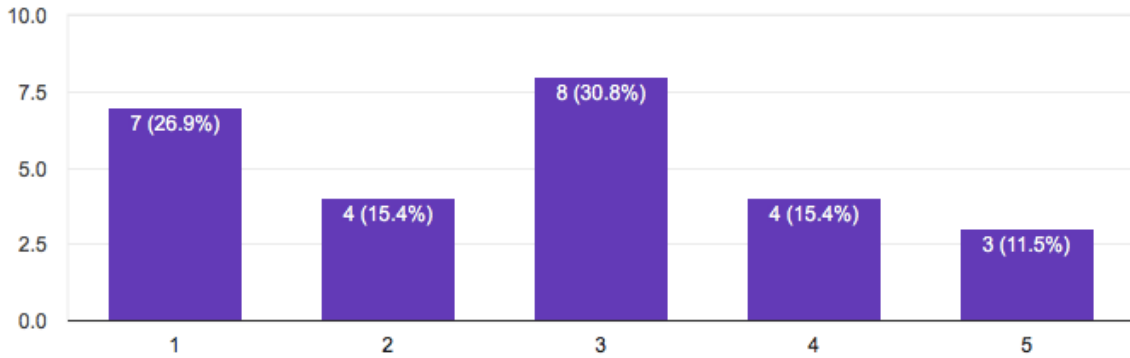

### Does the window protector need to look good when the open position (Not protecting Window)

26 responses

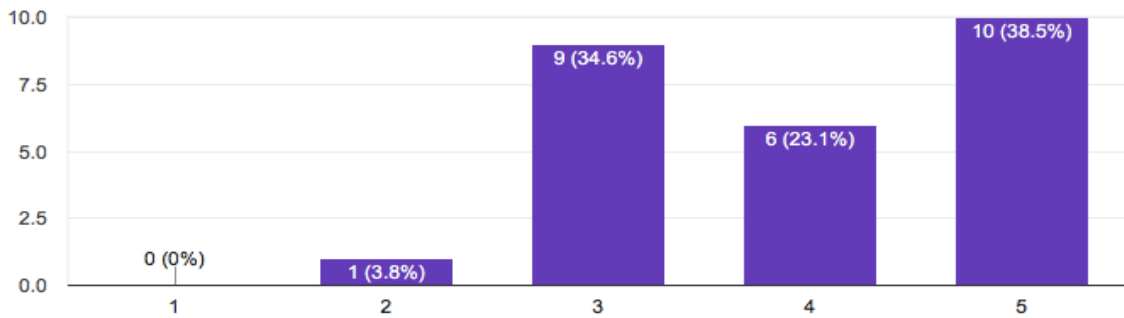

### Would you want the ability to close and open the window protector via your Cell Phone?

26 responses

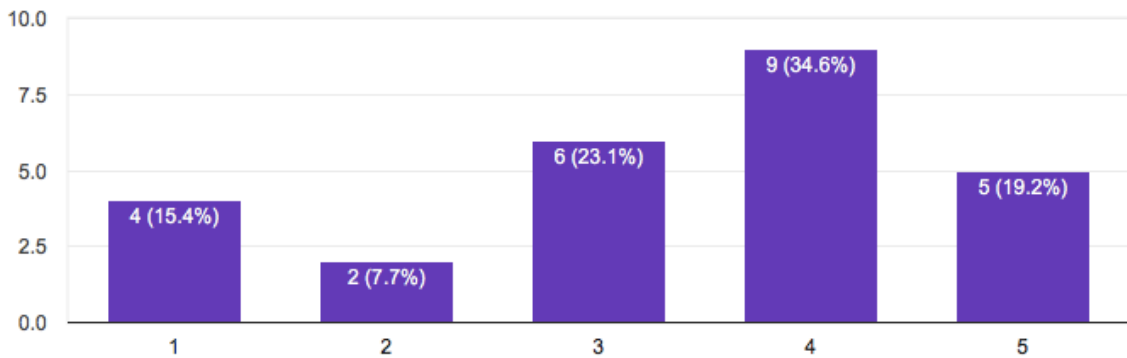

### Does your window protection need a locking feature?

26 responses

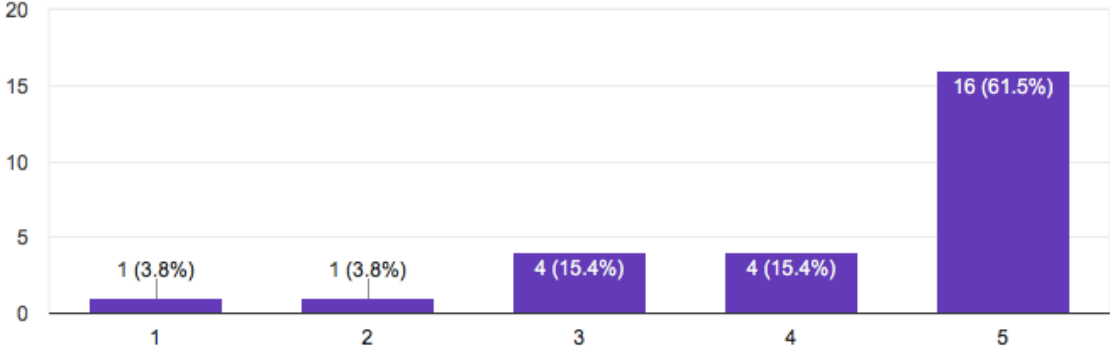

### Does the Window Protector need to look good when it is in the closed position? (protecting the window)

26 responses

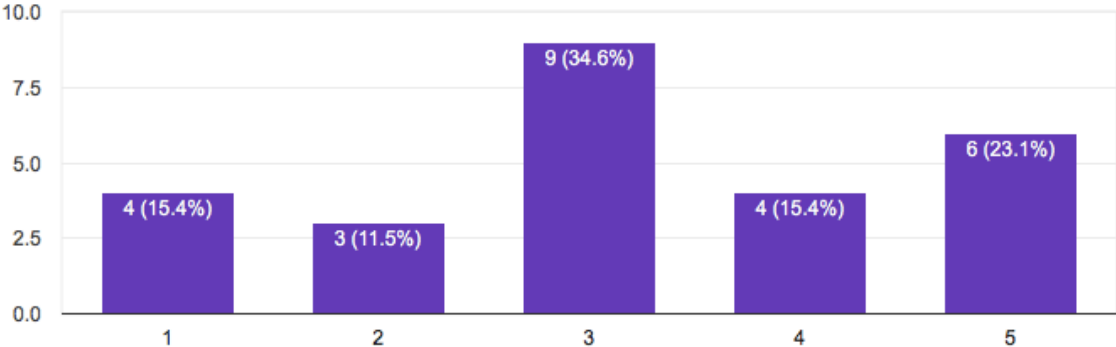

### Would you want your kids to be able to close the protectors?

26 responses

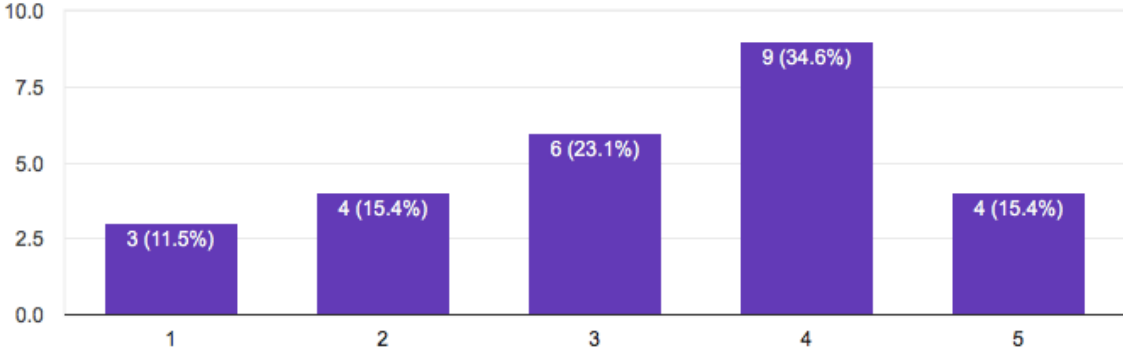

### Window Protector can withstand objects hitting it at 100+mph.

26 responses

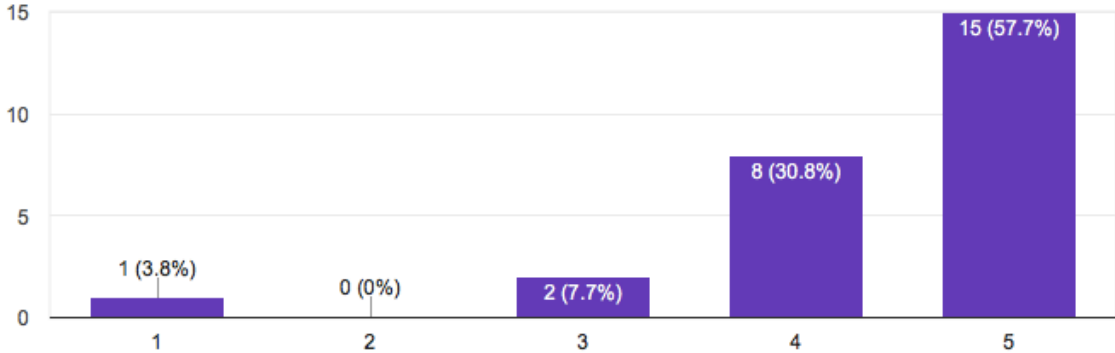

### Does the protector need to be open and closed manually if need be?

26 responses

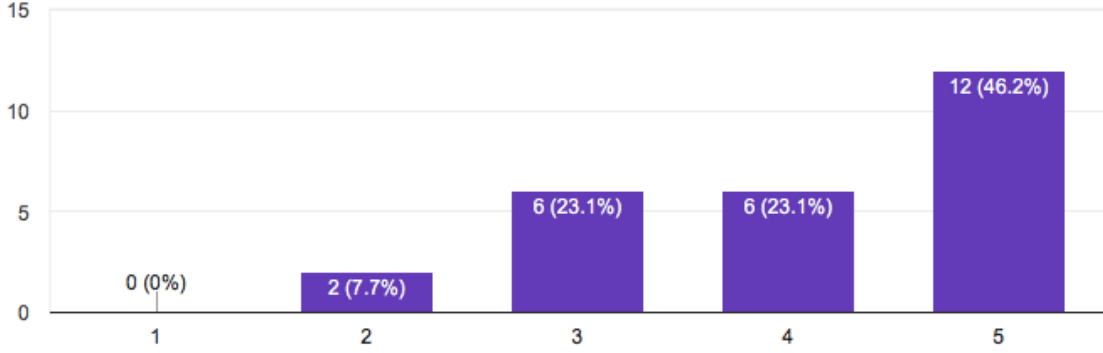

### Does the window protector need a control panel in the house to activate it? (like a thermostat)

26 responses

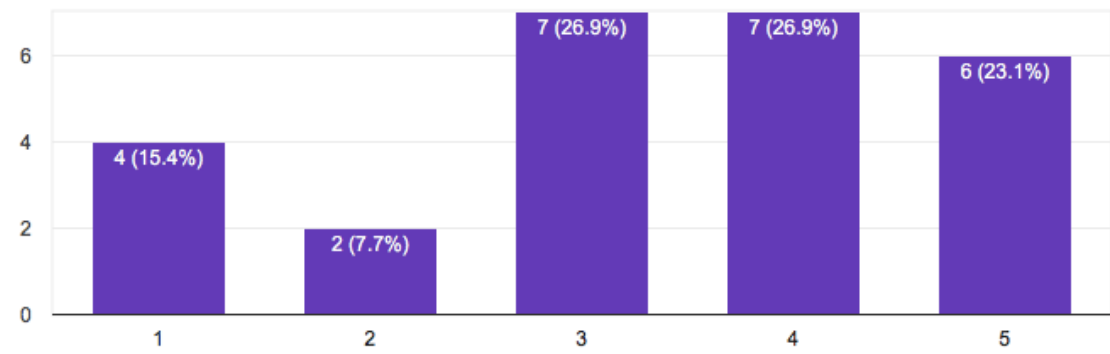

## **Interview Questions**

For the first interview we asked questions to a person whose residence is in Ohio, but has a vacation home in Tampa Florida.

Q: What do you feel is the most important thing to do when preparing your home for hurricanes or severe storms?

A: Wind and rain seem to be the biggest concerns with the hurricanes we've had lately, so I would say boarding up your windows and putting sand bags around all entrances to the home to help prevent flooding.

Q: Do you have any type of window protection on your home right now? If no, then why not?

A: No we do not. We just recently purchased the home, but we are looking into adding some onto the house in the future.

Q: What do you think is the most important feature for a window protection system to have?

A: I've done a little bit of research on them and I would say for them to be sturdy and strong is very important. A lot of the ones I looked at didn't seem like they would protect the window that well with high winds.

Q: For people that have vacation homes in hurricane zones, do you think it would be beneficial for them to be able to control their window protection from their phones if they aren't at their home?

A: Yes, that would be a great idea as we are one of those type of people. It would be nice to not have to worry about going down to Florida every time there is going to be a severe storm.

Q: What do you think could be improved on the current window protection systems?

A: I'm not real familiar with all of them that are on the market, but I would say the strength and durability of them

Q: What do you think is a reasonable price for a window protection system on your home?

A: This is tough to answer because I think it really depends on the value of your home and size of the windows. For our home I would be willing to pay up to \$300 per window for a reliable system

Q: Would you leave your window protection up all season long if it had an elegant look to it?

A: I think this would be very beneficial. I wouldn't want to have to worry about putting them up and taking them down all the time. Especially since we won't be there year round.

Q: Are there any questions or tips you have for me or about the design we are trying to make?

A: I think you have a good start and I look forward to seeing the end result. I think the hardest thing is going to be making the product affordable, so you need to plan who you're trying to target.

For the second interview we asked questions to a man who worked for a construction company in Florida.

Q: What do you feel is the most important thing to do when preparing your home for hurricanes or severe storms?

A: The customers that we have recently built houses for have been asking for reinforced windows, cinder blocks, and reinforced concrete pillars. This tells you what they are most concerned about. My first instinct would be to board up the windows, as they are the most vulnerable.

Q: Do you have any type of window protection on your home right now? If no, then why not?

A: I do not. Plywood works just as good as the cheap ones on the market and I cannot afford the nice reliable ones.

Q: What do you think is the most important feature for a window protection system to have?

A: Durability is a no brainer to me. If you're going to be spending a good amount of money, you want something that is going to last and actually work

Q: For people that have vacation homes in hurricane zones, do you think it would be beneficial for them to be able to control their window protection from their phones if they aren't at their home?

A: This would be a very nice feature to have. Technology is prone to fail so I would suggest having a plan b way to operate them.

Q: What do you think could be improved on the current window protection systems?

A: It depends on the type of protection you have. The classic storm shutters are weak and don't do a great job at high wind speeds. The roll down protection has had mechanical issues and usually has thin material.

Q: What do you think is a reasonable price for a window protection system on your home?

A: Again I think it depends on the system. I would pay around \$200 for a good quality system. But if I were able to I would easily go up to \$500 for something I know will get the job done

Q: Would you leave your window protection up all season long if it had an elegant look to it?

A: I think this would be the best option. I know a lot of people who take theirs down in the off storm season, but you just never know when you'll need them. Also, the good thing about a lot of these storm protections are they also add security to your home. During evacuations there are a lot of homes that get looted, so that is another aspect to think of when making this,

Q: Are there any questions or tips you have for me or about the design we are trying to make?

A: I would suggest to try and make a very stable unique system that will be able to get the job done but not break the bank. There are a lot of high dollar systems out there and a lot of cheapies but the market in between them is still open.

