

# **NOTE TO USERS**

**This reproduction is the best copy available.**

UMI



THE "WOLF" TONE OF THE PIANOFORTE

A Thesis

Presented to the  
Faculty of the Graduate School  
of the  
University of Cincinnati

by

Armand Frank Knoblauch

B. S. E., University of Cincinnati, 1925

A. M., University of Cincinnati, 1927

In partial fulfillment of the requirements

for the degree of

Doctor of Philosophy in Physics

Cincinnati, Ohio

June, 1929

UMI Number: DP16714

## INFORMATION TO USERS

The quality of this reproduction is dependent upon the quality of the copy submitted. Broken or indistinct print, colored or poor quality illustrations and photographs, print bleed-through, substandard margins, and improper alignment can adversely affect reproduction.

In the unlikely event that the author did not send a complete manuscript and there are missing pages, these will be noted. Also, if unauthorized copyright material had to be removed, a note will indicate the deletion.

UMI<sup>®</sup>

..

---

UMI Microform DP16714

Copyright 2009 by ProQuest LLC

All rights reserved. This microform edition is protected against unauthorized copying under Title 17, United States Code.

---

ProQuest LLC  
789 East Eisenhower Parkway  
P.O. Box 1346  
Ann Arbor, MI 48106-1346

Letter of Transmittal

To the Faculty of the Graduate School,

University of Cincinnati

Cincinnati, Ohio

Gentlemen:

I herewith submit a thesis, "The 'Wolf' Tone of the Pianoforte", as fulfillment of part of the requirements for the degree of Doctor of Philosophy in Physics.

The results of the work indicate that the cause of the "wolf" tone is essentially a longitudinal vibration of the bass string.

Respectfully submitted,

*A. F. Knoblauch*

A. F. Knoblauch

## Introduction

The writer has had occasion to examine an acoustic phenomenon which, to the best of his knowledge, had never been explained satisfactorily and which has not been noted in scientific publications. This phenomenon occurs in the bass section of all makes of pianofortes and is termed a "wolf" or "clang" tone by piano makers. It consists in a high-pitched sound, emitted with the bass tone when the string is struck in the usual manner by the hammer and is distinctly audible. The pitch of the sound is constant for any one string but varies with string dimensions, being higher for the shorter, lighter bass wires. As the phenomenon is the superposition of a high-pitched tone on a low-pitched one, it detracts from the musical quality of the pianoforte bass.

The frequency range of the "wolf" tones on the pianos the writer has examined, is from 500 to 3000 vibrations per second, whereas the frequency range of the fundamental tones of the bass strings, in which the "wolf" tones arise, is from 27 to 80 vibrations. It was thought, from the large interval between these two ranges, that the cause of the tone would not be found in the ordinary theory of hammered strings. Ghosh<sup>1</sup> and others have shown that the Fourier series of partial tones produced in strings struck by hammers is convergent. Thus, for ordinary strings and hammers, the partials around and above the fifteenth should be very weak. The "wolf" tone, if it be a high partial of the transverse modes of the string, should therefore be of low intensity; this is contrary to fact.

As a first attack on the problem of finding the cause of the "wolf" tone, the writer decided to determine accurately the frequency and complexity of this "wolf" effect, with the hope of establishing some relation between experimental results and the dimensions of the strings, hammers and soundboard of the piano. To this end, he made use of a tone analyzer which he had constructed.

### Description of Apparatus

The tone of the pianoforte, like a great many musical sounds, is complex in character and of transient nature. The intensity rises to a maximum in about one tenth of a second, falls rapidly for two seconds and becomes inaudible in approximately twenty seconds. A physical description of such a sound requires its analysis into sine wave components and the history of each component.

In recent years, the accurate ways of analyzing acoustic vibrations have employed the use of mechanical devices or the use of electrical methods. Of the former way, a noteworthy example is the phonodeik of Dr. D. C. Miller<sup>2</sup>, by means of which a graph of the instantaneous, representative wave form of a tone can be secured. The wave depicted by this graph can be separated into a Fourier series of components, with the aid of a rolling sphere, integrating type of analyzer. Of the electrical methods, the best modern development is the frequency analyzer of Messrs. Wegel and Moore.<sup>3</sup> With this machine, any complex, continuous wave can be separated into sine components.

The phonodeik has the advantage of following rapidly varying intensities but, due to the characteristics of the mechanical type of analyzer, it is limited to analysis by Fourier series.

The analyzer of Wegel and Moore separates a complex, continuous wave into a series of trigonometric components, whether or not they be in the progression represented by a Fourier series. It employs a series impedance circuit, consisting of capacity and inductance, which will indicate, by resonance, any frequency within its scope. The limitation of Wegel and Moore's apparatus is the sluggishness of the indicating meter,

and because of this, rapidly varying tones can not be analyzed.

The present investigation required an analyzer giving quick response and not limited to harmonic components. Therefore it was decided to use an apparatus similar in principle to that of Wegel and Moore but designed to follow rapid fluctuations. This necessitated the development of a special short-period galvanometer.

The schematic diagram of the analyzer is shown in the accompanying Figure 1. The aerial vibration of the tone is picked up by a capacity microphone and increased in intensity, as an alternating current, by a vacuum-tube amplifier (Amplifier No. 1). The various components of the tone are shunted out, in turn, by a variable series-tuned circuit, from which energy is transferred through a high ratio transformer.

Amplifier No. 2 increases the intensity of a particular component shunted out by the series-tuned circuit, so as to bring the energy level up to a point comparable with the sensitivity of the indicating meter.

The output current of Amplifier No. 2 is rectified and then conducted to the meter.

Let us consider in detail each part of the apparatus.

#### Microphone

The capacity microphone, or condenser transmitter, developed by the Bell System Laboratories into a most satisfactory device for transforming sound waves into electrical currents, has been described by Wente<sup>4</sup> and Crandall<sup>5</sup>, and the instrument has been found to give a uniform response over the range of frequencies ordinarily encountered.

in musical tones, with an increased response at low frequencies. The microphone of the Bell System Laboratories has a sensitivity of about 0.275 millivolts per dyne, per square centimeter, as sound pressure. It can be calibrated by means of a thermophone<sup>6</sup>.

#### Amplification System

The vacuum-tube amplifiers used in the analyzer are of the resistance-coupled type, furnishing uniform response over practically the entire audio range. The tubes are of large current capacity to secure freedom from distortion.

The average sound pressure encountered in tone analysis work was estimated at 10 dynes per square centimeter, and, as a convenience for measurement, a current of about 0.25 milliamperes ought to flow through the series-tuned circuit as a result of this pressure on the microphone. Morecroft<sup>7</sup> and others have deduced formulae for the response produced by resistance-coupled amplifiers, and, with the use of these formulae and tube data, keeping in mind the output desired, the amplifiers were designed. Amplifier No. 1 is a five tube device, giving 0.250 milliamperes in the unloaded plate circuit of the last tube, for one millivolt applied to the grid of the first tube. Amplifier No. 2 has three tubes and gives 0.210 milliamperes per millivolt applied.

#### Series-Tuned Circuit

The output of Amplifier No. 1 is directed into a system containing the series-tuned circuit and an impedance network, in parallel. The purpose of the network is to allow passage of the direct current component of the last tube of the amplifier and to counterbalance discrepancies that may be in the response of the system. The series-tuned

circuit selectively shunts components of the alternating current from the network.

The steady-state impedance of a series-tuned circuit is given by

$$\sqrt{R^2 + \left(2\pi fL - \frac{1}{2\pi fC}\right)^2}$$

where R = resistance  
 L = inductance  
 C = capacity  
 f = frequency

The maximum current will pass through the circuit when this is a minimum, that is, when

$$f = \frac{1}{2\pi\sqrt{LC}}$$

As there are practical advantages in varying the capacity rather than the inductance, the inductance of the circuit was set at either of two values and the capacity made selective.

Steinmetz<sup>8</sup> has discussed the theory of transient oscillations in circuits and, for series impedance networks, found an important factor to be the decrement,  $\frac{R}{2L}$ . This is an index of the rate at which the current in a circuit reaches its steady-state amplitude under a uniform, impressed alternating electromotive force.

For the analysis of transient vibrations, the decrement of the circuit should be large, that is, the resistance should be large compared to the inductance. However, for sharp resonance, the inductance must be large compared to resistance.

The proper choice of inductance and resistance in the circuit is then a matter of judgement, and it was decided that an inductance of 25 millihenries with a resistance of between 1.5 and 5 ohms was

approximately correct for the transient conditions to be met and the frequency range encountered. To minimize the effective resistance of the circuit, a coil with a core of high permeability and small electromagnetic losses must be used.

With such a value of inductance in the circuit, the decrement is, for a resistance value of 1.5 ohms,

$$\frac{R}{2L} = \frac{1.5}{2 \times 25 \times 10^{-3}} = 30$$

With this decrement, it was estimated that the current in the circuit would reach 99 per cent of its steady state amplitude, under a uniformly impressed electromotive force, in one tenth of a second. This time is satisfactory for the observations to be made.

To secure an inductance with the characteristics demanded, the writer constructed a coil having a powdered iron core. The coil is toroidal in shape, the core having a mean diameter of 10.05 centimeters and a rectangular cross-section of 5.3 by 3.3 centimeters, and is wound in four sections, each having 400 turns of wire. With the four sections in parallel, the inductance of the coil, as determined on an inductance bridge, was constant at 23.8 millihenries for currents up to five milliamperes and the resistance increased from 0.45 ohms for direct current to four ohms at 5000 cycles. Two other coils, one having a core of silicon steel laminations 0.035 centimeters thick and the other a core of laminations of the same material 0.007 centimeters thick, were tried, but both were unsatisfactory.

A switching arrangement in the circuit allows the four sections of the coil to be placed either in series or parallel, thus allowing two

frequency ranges, 25 to 1000 cycles and 80 to 10,000 cycles to be covered. For the series connection, the inductance is 480 millihenries.

The values of capacity used in conjunction with the inductance vary continuously from 200 microfarads down to 0.01 microfarads, with decade switching arrangements. Up to six microfarads, mica condensers are used to keep down effective resistance resulting from dielectric losses. The larger condensers are of paraffined paper. A small air condenser is added to the circuit as a vernier.

The primary winding of the coupling transformer, which is contained in the circuit, adds a small resistance and inductance both of which are negligible, since the primary contains only 30 turns of wire, and has its secondary of some 5000 turns operating into the grid circuit of the first tube of Amplifier No. 2.

#### Rectifier

The rectifier, of the full-wave type, has as its elements four copper-cuprous oxide plates, each three centimeters square. In experimenting with this part of the apparatus, an interesting property of the rectification was discovered. This is displayed on the accompanying Graph Sheets Nos. 1, 2 and 3.

Sheet No. 1 shows that the conversion of alternating current into direct is not linear and indicates that the rectification is less efficient at high than at low frequencies. The writer suspected that the curves on this sheet might be parabolas and so replotted them, using the square roots of the rectified current values as ordinates. The results were straight lines, a sample one of them being shown on Graph Sheet No. 2, and they prove that, for current densities, up to

the order of 0.1 milliamperes per square centimeter, the rectified current is proportional to the square of the input alternating current.

It will be noticed that the straight line of Sheet No. 2 does not pass exactly through the origin. This slight discrepancy was noticed on all the replots and may represent a "work function" or an index of the energy required to transport an electron from the copper to its oxide.

It was suspected that the decrease in rectification efficiency with increasing frequency might be due to the capacity of the rectifier plates, that is, that the rectifier might be equivalent to an impedance containing a capacity and resistance in parallel. If this be the case, then the value of the rectified current should be independent of the frequency if the alternating voltage applied across the rectifier be held constant. The results of a test of this nature are shown on Graph Sheet No. 3, and confirm the suspicion.

The "square" property of the rectifier is an aid in tone analysis. For, at any one frequency, the rectified current is proportional to the square of the alternating current. The square of the alternating current is proportional to the square of the voltage generated in the condenser transmitter, and, this, in turn, is proportional to the square of the sound pressure. But the square of the sound pressure, multiplied by a constant factor, is equal to the rate at which energy flows across unit area of wave front. Hence, by using a current meter attached to the rectifier, whose readings are directly proportional to current strength, we can read sound power directly.

#### Meter

The recording meter is a modification of the d'Arsonval galvanometer

It is shown schematically and in photograph, in Figure 2. The moving coil has been made light to shorten its period, and to maintain sensitivity, it is placed in a magnetic field of 5000 gauss. A damping loop, attached to the coil, brings it to a slightly overdamped condition. The deflections of the coil are measured by an optical system including a microscope with a linear eyepiece scale. The meter has a period of about 0.07 seconds, and a sensitivity of  $5 \times 10^{-6}$  amperes per division, for a microscope magnification of 150 diameters. A resistor, variable from 0 to 10,000 ohms, is placed in series with the meter to adjust the sensitivity of the analyzer.

#### Calibration of the Analyzer

By the use of a variable frequency vacuum-tube oscillator and a thermocouple for measuring small alternating currents, the voltage calibration of the analyzer was secured. The sensitivity curve of the Bell System Laboratories' condenser transmitter has been given by Wente<sup>4</sup> and Grandall<sup>5</sup>. By combining these two results, the acoustic calibration curve of the analyzer can be drawn. This is shown on Graph Sheet No. 4.

#### Laboratory

The room containing the analyzer has been made fairly free from reverberation by covering the walls with Celotex board and the floor with cork.

#### Accessory Apparatus

To secure a standard blow on the pianoforte key, a striker, shown in an accompanying photograph, was constructed. It consists of a brass arm, movable about a horizontal axis at its middle, adjustable in height, and carried on a vertical rod mounted on a floor base. One end of the arm has a felt-covered knob attached for striking the pianoforte key, and the other a lanyard with which the hammer can be raised. A stop for

regulating the upper position of the hammer is included, and an adjustable weight can be placed at notched points along the arm.

In order to compare the distribution of power in the tone of the piano with the distribution of energy in the vibrating string, the writer constructed an apparatus for photographing the motion of a string as shown in Figure 3. A view, as if the observer were above the apparatus and looking down on it, is drawn. The monochord consists of a heavy double beam, about three meters long, the space within the double beam being available for inserting a piano hammer and its action. The string is carried over sharp edged brass bridges, attached to the monochord and adjustable to any position along the beam, and is connected to a dynamometer. It is tuned by a turnscrew and the corresponding tension read. The illuminating and photographing system consists of an arc lamp, a condensing lens for concentrating the light on the string, an adjustable shutter for regulating the photographic exposure, a magnifying lens, and finally a vertical slit and a film drum directly connected to a motor.

The arc lamp is of the 110-volt, portable type. The shutter, of the bulb type, can be regulated to give exposures from one hundredth of a second to three seconds. The magnifying lens has focal length of about 4 centimeters. The film drum is driven at 1000 r.p.m. and rotates about a vertical axis. It is seven centimeters in diameter, and carries a photographic film wrapped on its periphery and held on with spring clips. The vertical slit is one fourth of a millimeter wide and ten centimeters high. Appropriate light baffles are placed around the lenses and drum.

The hammer action is placed under the string, the hammer striking

the string from beneath as in a grand pianoforte.

It is seen that since the string moves in a vertical plane, whereas the film is carried horizontally, a record of the motion of the string will be traced on the film.

### Experimental Results

For the experimental work, two grand pianofortes of well-known make were selected, one being seven and the other, five feet in length. Each, in turn, was placed in the laboratory and those bass notes which had prominent "wolf" tones were analyzed according to the following procedure.

The blow striker, with a 2 kilogram weight attached at a distance of 7.5 centimeters from the fulcrum on the knob side of the arm, was placed in position before the key to be struck, the knob, in its upper position, being three centimeters above the key. The tones resulting from the fall of the knob on to the key could be said to be forte in strength, to use a musical term. For each blow of the hammer, the maximum deflection of the meter coil of the analyzer was observed, and between each successive blow, the resonance frequency of the series-tuned circuit was increased a small amount, the frequency at the start being well below the frequency of the "wolf" tone and that at the end being above 10,000 cycles per second.

It was noticed that the movement of the meter coil agreed well with the transient nature ascribed to a pianoforte tone.

For each note, the deflection values of the meter coil were plotted as ordinates against frequency as abscissae. The results were a series of peaks, the ordinate of the top of each peak being taken as an indication of the maximum power of a tone component and the abscissa as the frequency of the component. From the calibration curve of the analyzer, the maximum acoustic powers of these components were determined, and plotted against frequency. The results are shown on the accompanying

Graph Sheets Nos. 5, 6, 7, and 8.

For purposes of comparison to be mentioned later, a bass note an E of frequency 41.2 vibrations per second, was selected on the larger pianoforte, and the string and hammer were removed and placed in the apparatus for photographing vibrating strings. The string was tuned to the same frequency it had in the pianoforte and the hammer was placed so that its striking point on the string was the same as that in the piano. A blow, of the same order as those used in the "wolf" tone analyses, was delivered to the string, and, after a short interval, a photograph of the motion of a point on the string was taken. This photograph, shown on an accompanying sheet, was analyzed into a Fourier series according to a scheme given by Hawley Taylor<sup>9</sup> and the relative energy in each partial vibration, the energy in the first partial being taken as unity, was determined by the use of the theory of strings given by Lord Rayleigh.<sup>10</sup>

The data for the photograph is:

Effective string length .....	127.4 cm.
Tension .....	127.5 kg.
Mass density of string .....	1.136 grams per cm.
Striking point .....	18 cm. from one end
Photographic point .....	10.75 cm. from other end
Time of photography after hammer impact .....	about 0.25 seconds

### Discussion

The bass note E of the larger pianoforte, the vibration of the string of which was photographed, was selected because of its relatively good tone quality. By the method described in the last section, the following data for the distribution of energy in the vibration of the string of this note were secured for the first ten partials:

Partial Vibration	Relative Energy
I	1
II	2.82
III	4.03
IV	2.83
V	2.91
VI	1.05
VII	.43
VIII	1.01
IX	1.40
X	1.40

These data show a fairly even distribution of energy, and were extended and corroborated by a complete tone analysis of the note E and other bass notes on the pianoforte, the analyses showing an even distribution of acoustic power up to about the twenty-fifth partial tone. The actual amount of power in each partial was found to be very small from the acoustic standpoint, and hence the sensation of pitch arising when a piano bass note is struck must be subjective, being attributed to the subjective difference tone, discovered and discussed by Helmholtz.<sup>11</sup>

The fact that the hammer distributes quite a large part of its energy among the upper partials of the string gives us a probable explanation of the source of the energy in the "wolf" tone.

As for the cause of the "wolf" effect, the writer suspected at first that the phenomenon might be due to a torsional vibration of the

wrapping on the string. Bass strings are not uniform, but consist of a steel wire core, tightly wrapped with either a single or double layer of copper wire, so as to increase the mass density of the string without great increase in stiffness. A few simple calculations on the probable frequency of the torsional vibration served, however, to eliminate this type of vibration as a cause.

It was then thought that the "wolf" tone might be due to a longitudinal vibration of the string, and a careful consideration of this type of string movement has led to theoretical results which agree closely with those obtained experimentally.

In discussing the longitudinal modes of motion of a wrapped string, one can neglect the elastic effort of the wrapping, but must include the mass of the wrapping. The following differential equation of motion may then be used:

$$M \frac{\partial^2 \xi}{\partial x^2} = AE \frac{\partial^2 \xi}{\partial x^2}$$

where M is the total linear mass density of the string  
 E is the modulus of elasticity of the core material (steel)  
 A is the cross-sectional area of the core  
 $\xi$  is a small displacement in the x-direction, the direction of the axis of the string

and the formula for the velocity of propagation is thus

On dividing the velocity by twice the length of the string, we secure the frequency of the lowest longitudinal mode, or

$$f = \frac{1}{2L} \sqrt{\frac{AE}{M}}$$

This last equation must be modified slightly when adapting it to an actual wrapped piano string, since the wrapping does not extend entirely to the active ends of the string, there being a short section of about one centimeter at each extremity that is bare, for the purposes of

suspension and tuning.

Let us now calculate the frequencies of the lowest longitudinal modes of the strings of the notes, the "wolf" tones of which have been analyzed. We have

String of note E<sup>b</sup> of large pianoforte

type of wrapping - double	
total active length	133.6 cm.
double wrapped length	128.0 "
single wrapped length	2.4 "
bare length	3.2 "
mass density in double wrapped portion	1.186 grams per cm.
mass density in single wrapped portion	.802 grams per cm.
cross-sectional area of core	.0122 square cm.

frequency of lowest longitudinal mode      554 vibrations per second

String of note F of large pianoforte

type of wrapping - single	
total active length	129.1 cm.
wrapped length	125.7 "
bare length	3.4 "
mass density in wrapped portion	.670 grams per cm.
cross-sectional area of core	.00937 square cm.

frequency of lowest longitudinal mode      668 vibrations per second

String of note B<sup>b</sup> of large pianoforte

type of wrapping - single	
total active length	119.3 cm.
wrapped length	115.9 cm.
bare length	3.4 "
mass density in wrapped portion	.444 grams per cm.
cross-sectional area of core	.00853 square cm.

frequency of lowest longitudinal mode      845 vibrations per second

String of note B of small pianoforte

type of wrapping - single	
total active length	97.0 cm.
wrapped length	94.5 "
bare length	2.5 "
mass density in wrapped portion	.759 grams per cm.
cross-sectional area of core	.01025 square cm.
frequency of lowest longitudinal mode	874 vibrations per second

The above calculations were made with the use of a value of  $2.06 \times 10^{12}$  dynes per square centimeter for the modulus of elasticity of steel wire, given in the Smithsonian Physical Tables.

Let us now inspect Graph Sheet No. 5. We notice a prominent component at 538 cycles, in good agreement with the calculated value of 554. We notice only three other prominent components at 1081, 1618, and 2146 cycles, and we observe that

$$\begin{aligned} 1081/538 &= 2.01 && \text{or} && 2 \\ 1618/538 &= 3.009 && \text{or} && 3 \\ 2146/538 &= 3.99 && \text{or} && 4 \end{aligned}$$

The last three components must therefore be upper modes of motion of the longitudinal vibration.

Turning to Graph Sheet No. 6, we observe two prominent components at 613 and 663 cycles. These compare well with the calculated frequency of 668. We note only two other prominent components at 1319 and 1998 cycles and also that

$$\begin{aligned} 1319/663 &= 1.99 && \text{or} && 2 \\ 1998/663 &= 3.01 && \text{or} && 3 \end{aligned}$$

On Graph Sheet No. 7 there is but one large component at 811 cycles, to be compared with a calculated frequency of 845.

Graph Sheet No. 8 has a number of components in the lower frequency region. Let us select the two at 869 and 936 as being close to the calculated value of 874. The only prominent peaks above these two are at 1735 and 2614 cycles, and we note that

$$1735/869 = 1.995 \text{ or } 2$$

$$2614/869 = 3.008 \text{ or } 3$$

Now, pianoforte hammers do not strike the strings normally but at an angle of about  $20^\circ$  to the normal. The tangential component of the hammer motion may therefore be instrumental in exciting a longitudinal motion in the string.

If the pianoforte string, in the pianoforte, be stroked gently with the finger in a longitudinal direction a gentle tone arises from the soundboard, and the pitch of this tone is identical with that of the "wolf" tone. Thus the soundboard and bass bridge are capable of transforming a longitudinal string vibration into a sound wave. Berry<sup>12</sup> has shown that there is a longitudinal motion of a pianoforte bridge.

It is possible that the longitudinal vibration couples with the nearest transverse mode of the string, the sound board acting as the coupling agent. Some evidence of this coupling action is shown on Graph Sheets Nos. 6 and 8 by the two components at 613 and 663 cycles and 869 and 936 cycles respectively.

The various modes of the longitudinal vibration evidently combine to produce a definite sensation of pitch just as do the partial tones of any musical instrument, in their action on the ear.

On all of Graph Sheets Nos. 5, 6, 7, and 8, a number of small

components are noted. These are simply upper transverse modes of the string, as can be shown by securing their frequency differences and noting that these differences are very approximately even multiples of the frequency of the fundamental transverse mode.

The "wolf" tone is not heard in the treble of the pianoforte. This is undoubtedly owing to the fact that the frequencies of the longitudinal vibrations are very high.

### Conclusion

The "wolf" tone of the pianoforte has as its mechanism a longitudinal vibration of the bass string. This longitudinal action has harmonic modes, these modes coupling with the nearest transverse modes, through the medium of the soundboard.

The vibration may be excited by the tangential part of the hammer motion..

Bibliography

1. R. N. Ghosh, Physical Review, 2nd Series, Vol. XXIV, Page 456
2. D. C. Miller, "Science of Musical Sounds", The Macmillan Co.
3. R. L. Wegel and C. R. Moore, Bell System Technical Journal,  
April, 1924, Vol. III, No. 2, page 299
4. E. C. Wente, Physical Review, 2nd Series, Vol. X, No. 1, page 39  
" " " " " Vol. XIX, No. 5, page 496
5. I. B. Crandall, Physical Review, 2nd Series, Vol. XI, No. 6, page 449
6. H. D. Arnold and I. B. Crandall, Physical Review, 2nd Series,  
Vol. X, No. 1, page 22
7. J. H. Morecroft, "Principles of Radio Communication", John Wiley  
and Sons, Inc.
8. C. P. Steinmetz, "Transient Electric Phenomena and Oscillations",  
McGraw-Hill Book Co.
9. Hawley O. Taylor, Physical Review, 2nd Series, Vol. VI, page 303
10. Lord Rayleigh, "Theory of Sound"
11. Hermann Helmholtz, "Sensations of Tone, " Longmans, Green and Co.
12. G. H. Berry, Philosophical Magazine, Series 6, Vol. XXII, page 113

### Acknowledgements

The writer wishes to acknowledge his indebtedness to the members of the Physics Department of the University of Cincinnati, for the helpful technical advice given him, and especially to Dr. Louis T. More, Dr. Robert C. Gowdy, and Dr. Lowell M. Alexander, for their valuable and constructive criticism.

He furthermore wishes to express his appreciation of the assistance tendered him by President Schneider, through whose efforts this research was made possible, and of the financial support given by the Baldwin Company, of Cincinnati.

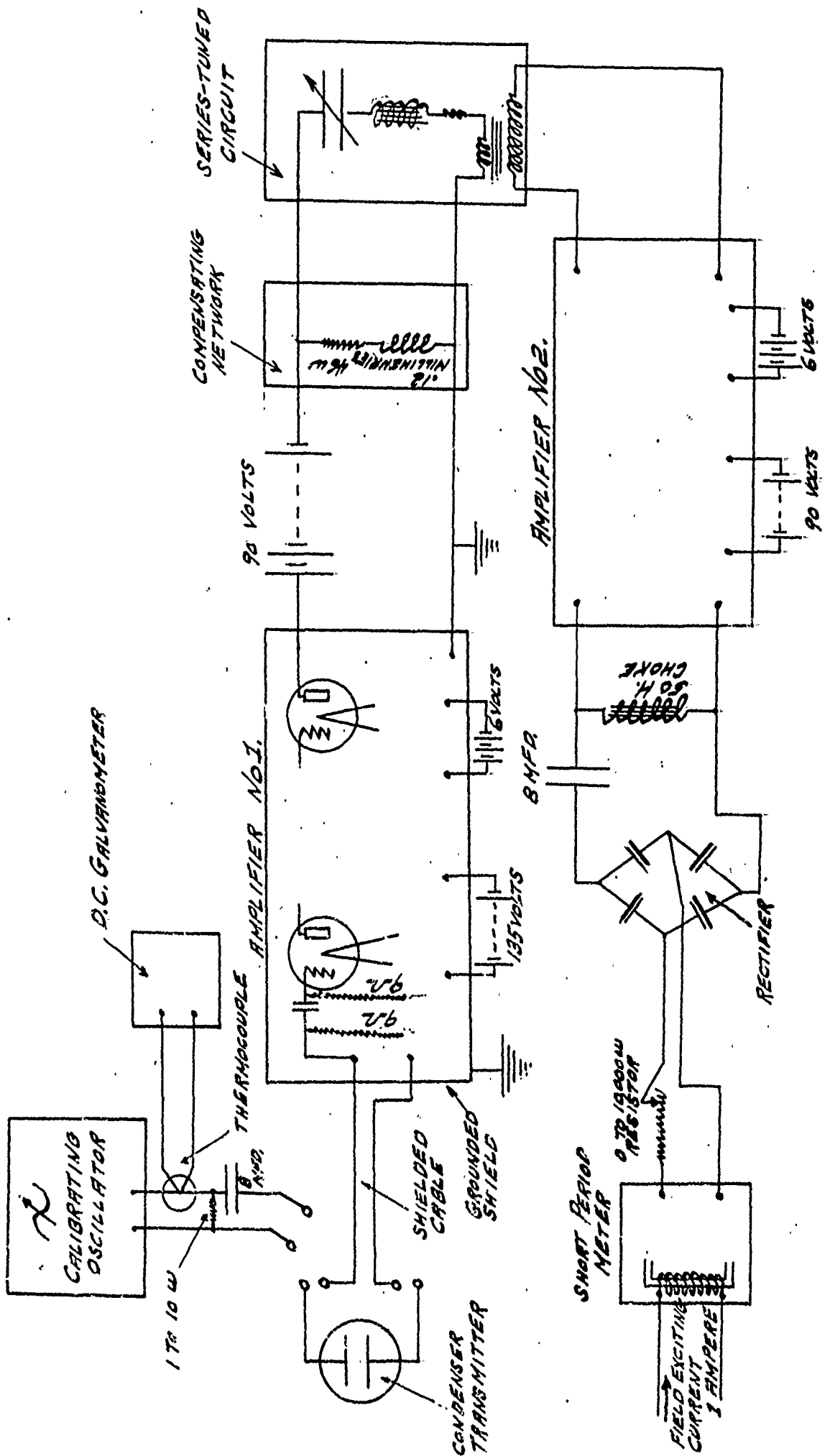

FIGURE I - SCHEMATIC OF ANALYZER

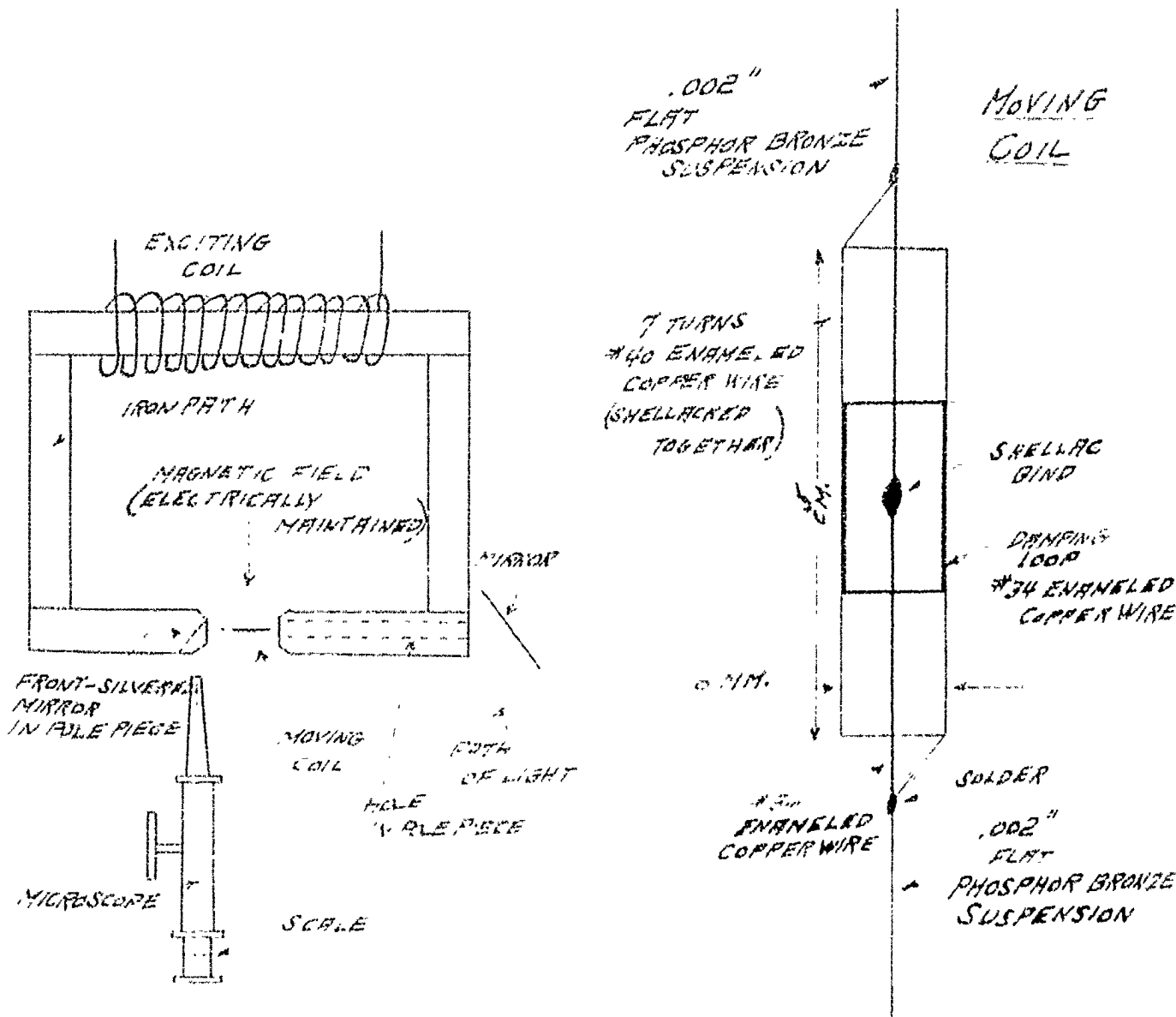

FIGURE 2  
METER

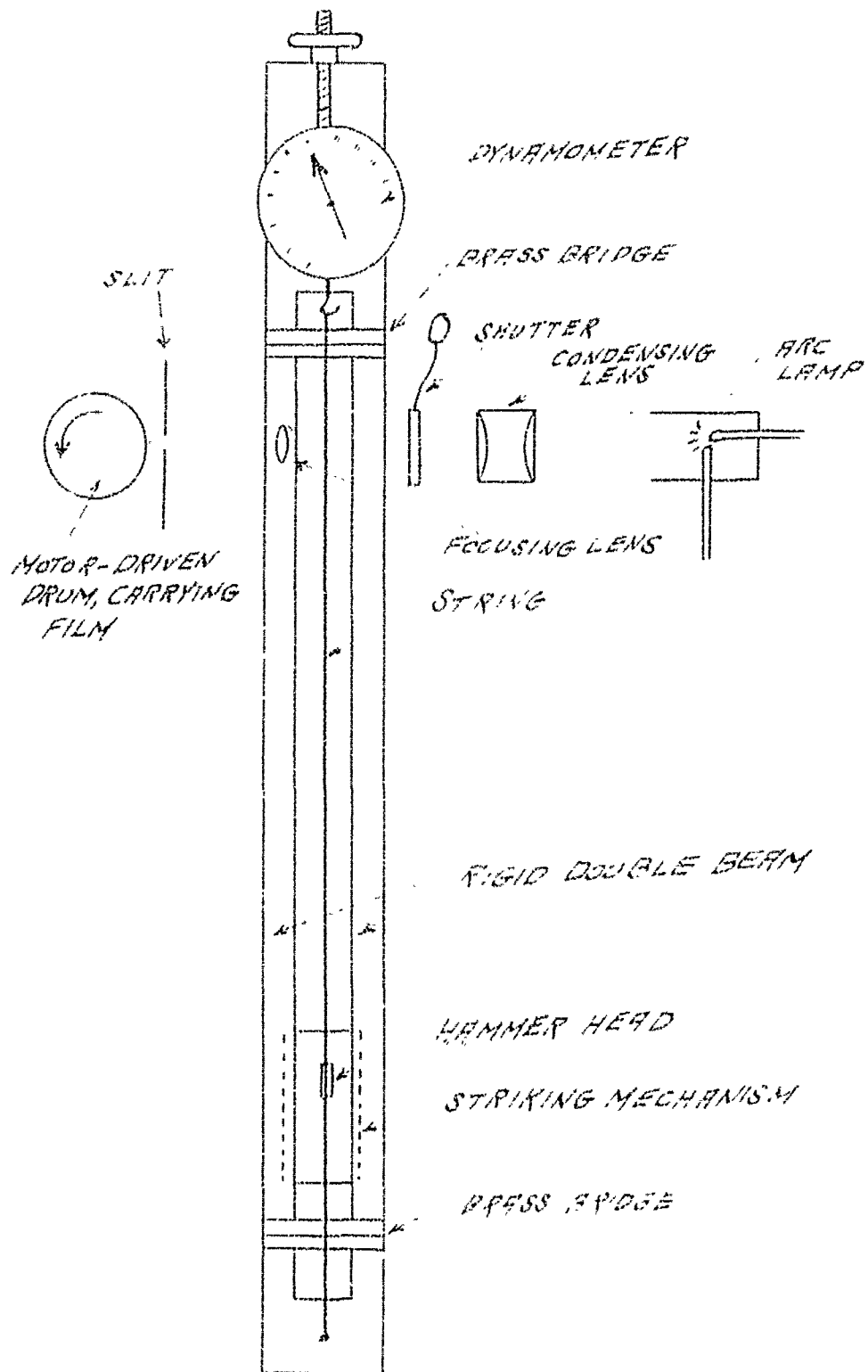
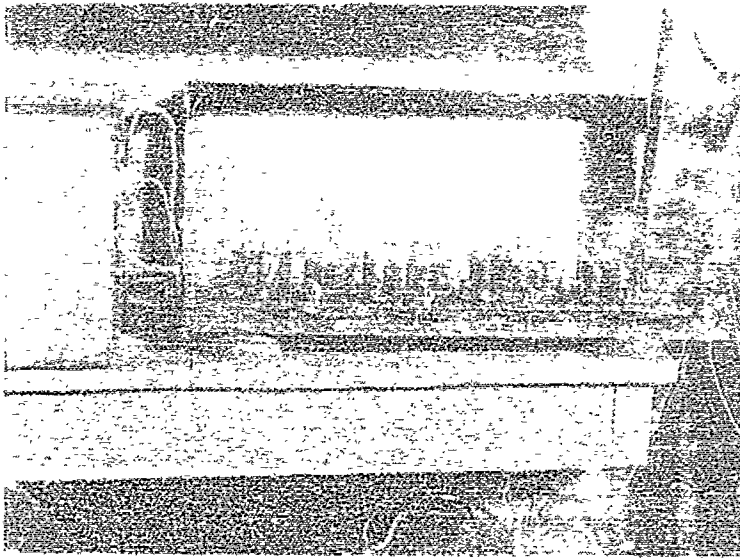
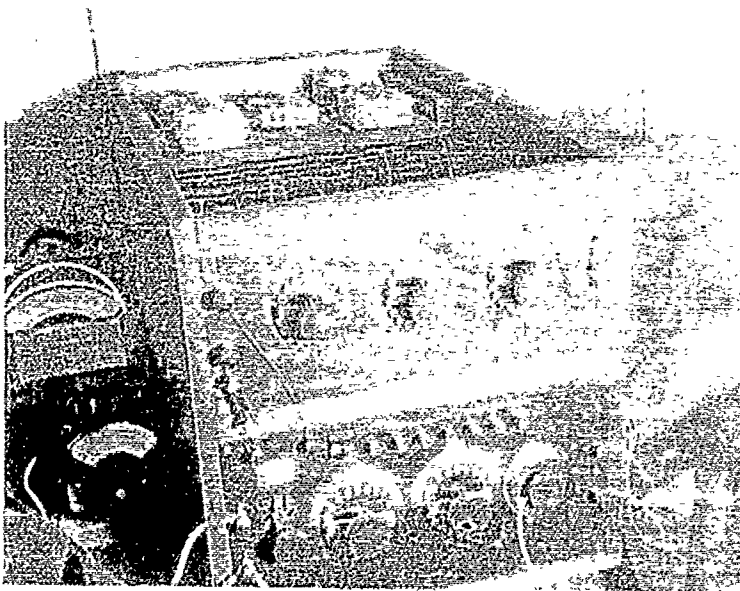

FIGURE 5  
 APPARATUS FOR PHOTOGRAPHING STRING



*AMPLIFIER NO 1.*



*SERIES - TUNED CIRCUIT*

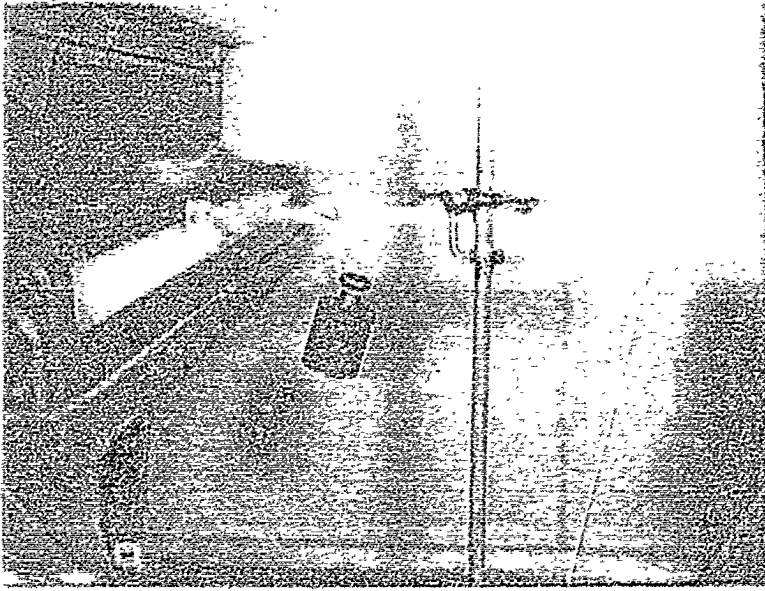

*STRIKER*

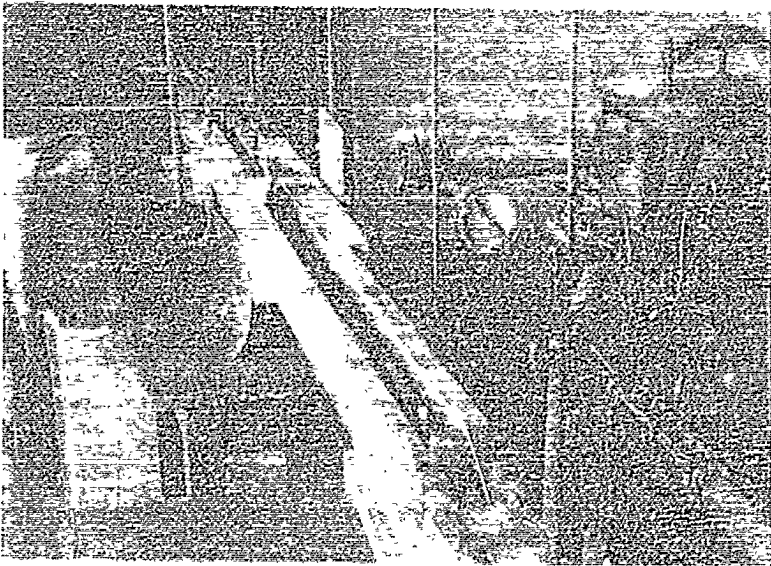

*PHOTOGRAPHIC APPARATUS*

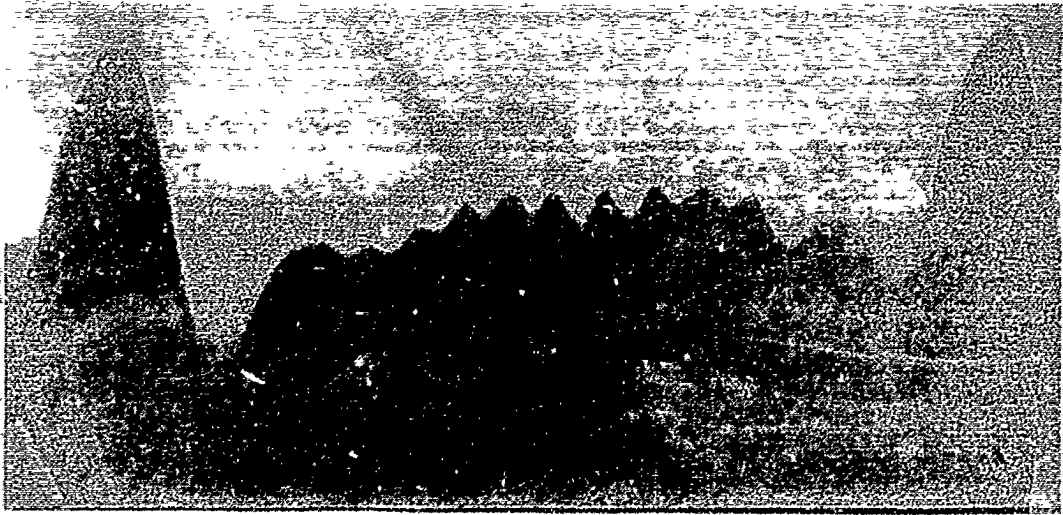

PHOTOGRAPH OF MOTION  
OF  
STRING OF NOTE E  
OF  
LARGE PIANOFORTE

GRAPH SHEET NO 1  
ACTION OF RECTIFIER  
AT VARIOUS FREQUENCIES

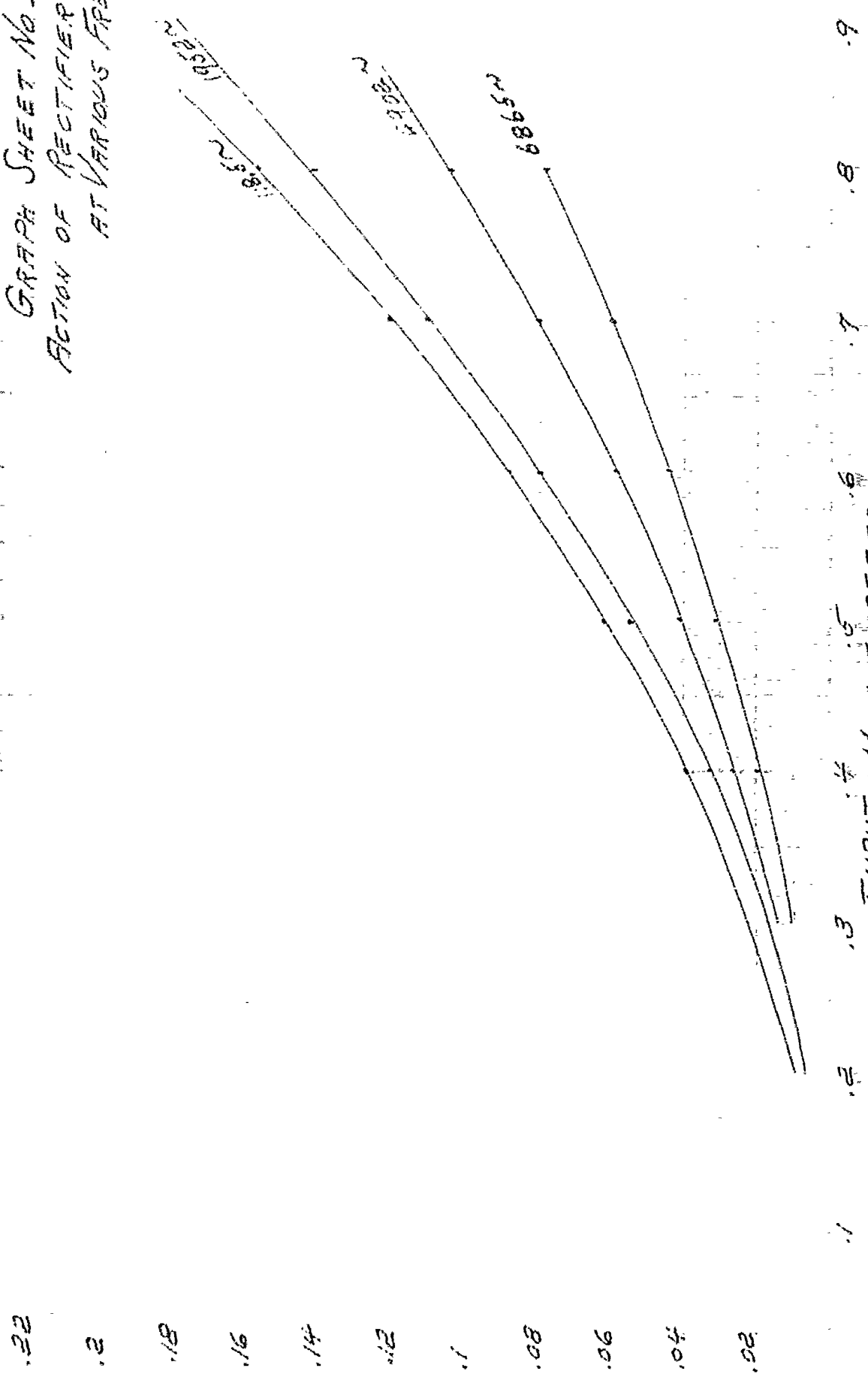

GRAPH SHEET No. 2  
 RE-LOT OF RECTIFIER  
 ACTION AT 1952 ~

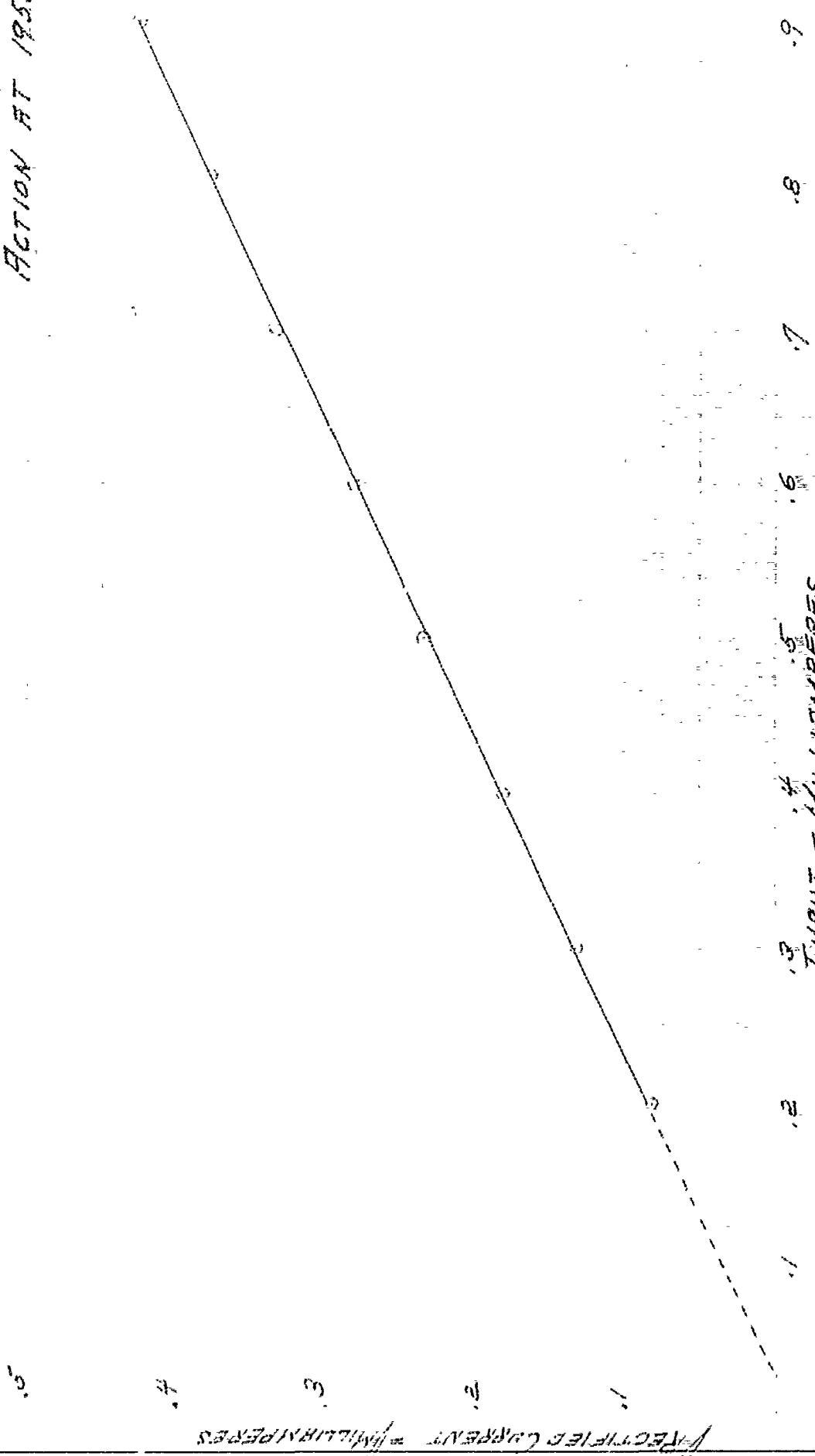

INPUT - MILLIAMPERES

RECTIFIER CURRENT - MILLIAMPERES

GRAPH SHEET No. 3  
ACTION OF RECTIFIER  
AT 297 MILLIVOLTS

RECTIFIED CURRENT - MILLIAMPERES

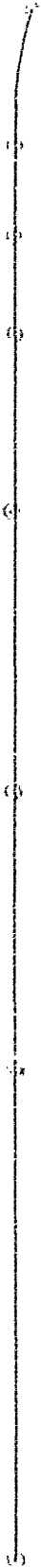

500 1000 2000 3000 4000 5000 6000 7000 8000

FREQUENCY - CYCLES PER SECOND

GRAPH SHEET No. 4  
 ACOUSTIC CALIBRATION CURVE  
 500 OHMS IN SERIES  
 WITH METER

8x10<sup>-2</sup>

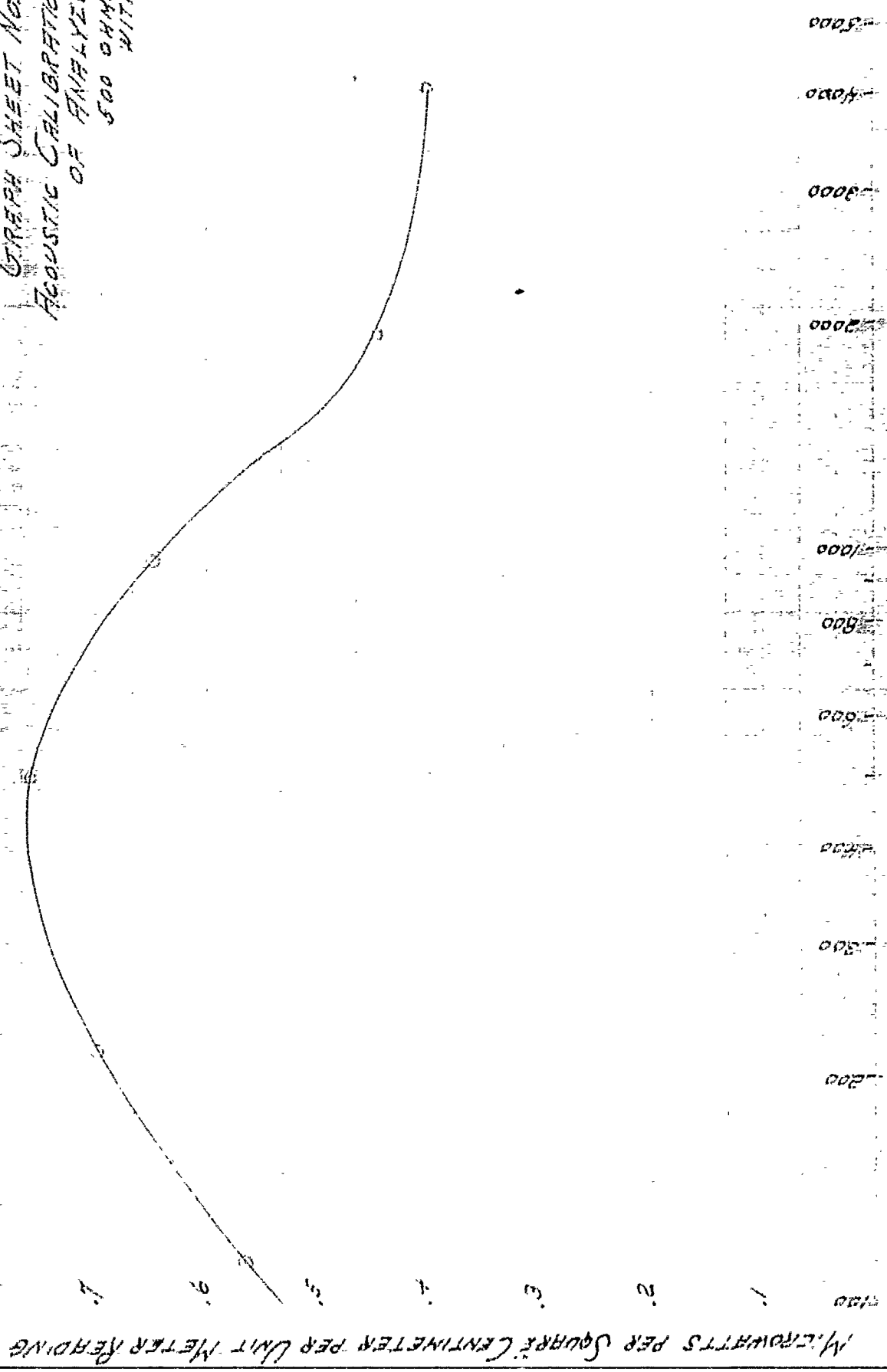

MICROWATTS PER SQUARE CENTIMETER PER UNIT METER READING

COMMUNITY - REC'D - DEC 10 1940



GRAPH SHEET No. 6  
 "WOLF" TONE ANALYSIS  
 LARGE PIANO FORTE  
 NOTE F 437 1/2 / SEC.

INTENSITY - MICROGRS PER SQUARE CM.  
 10 x 10<sup>-6</sup>

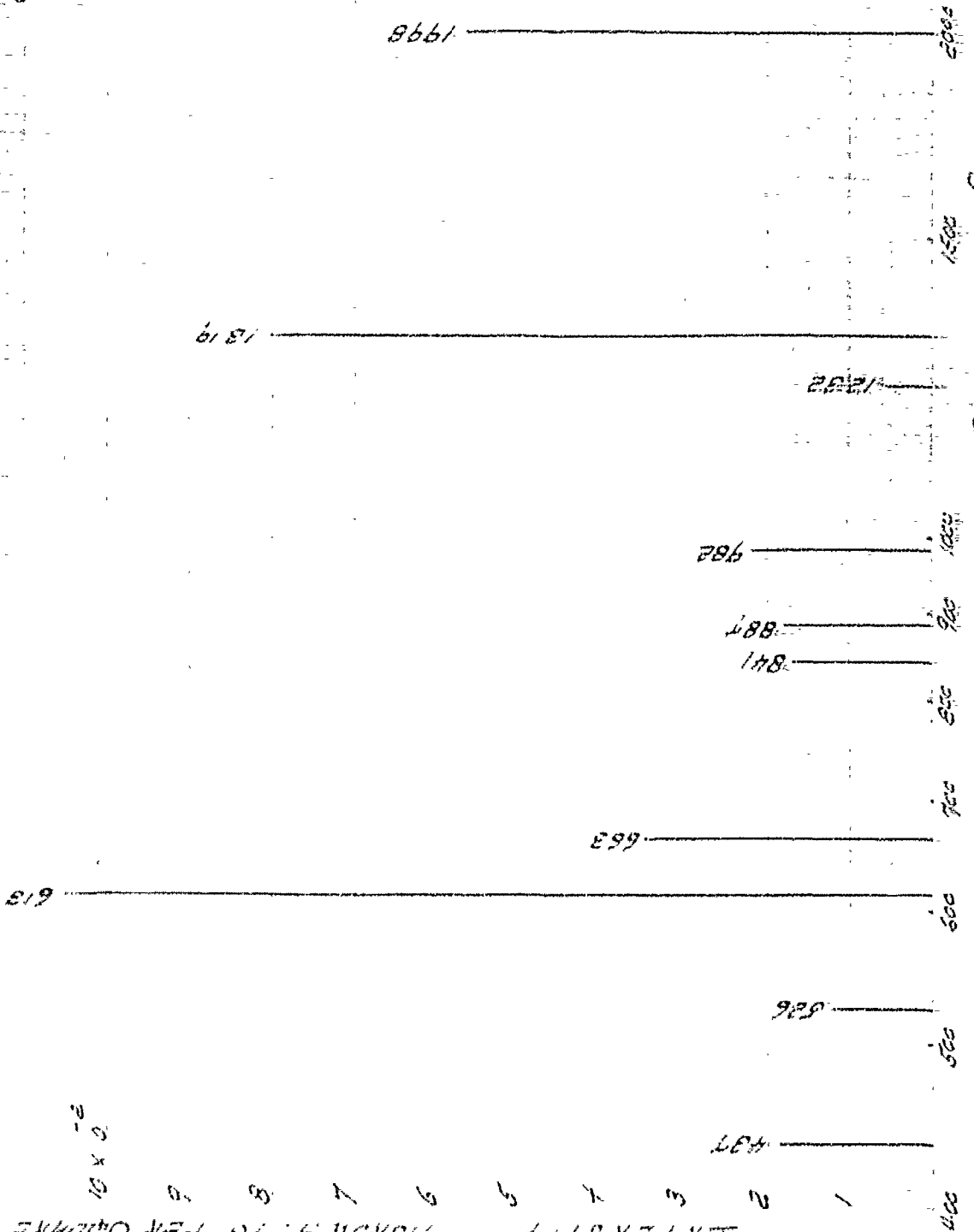

10,000  
 4000

FREQUENCY - CYCLES PER SECOND

GRAPH SHEET No. 7  
 "WOLF" TONE ANALYSIS  
 LARGE PIANO-FORTE  
 NOTE B<sup>6</sup> 58.3 ~/SEC.

INTENSITY - MICROWATTS PER SQUARE CM.  
 $10 \times 10^{-2}$

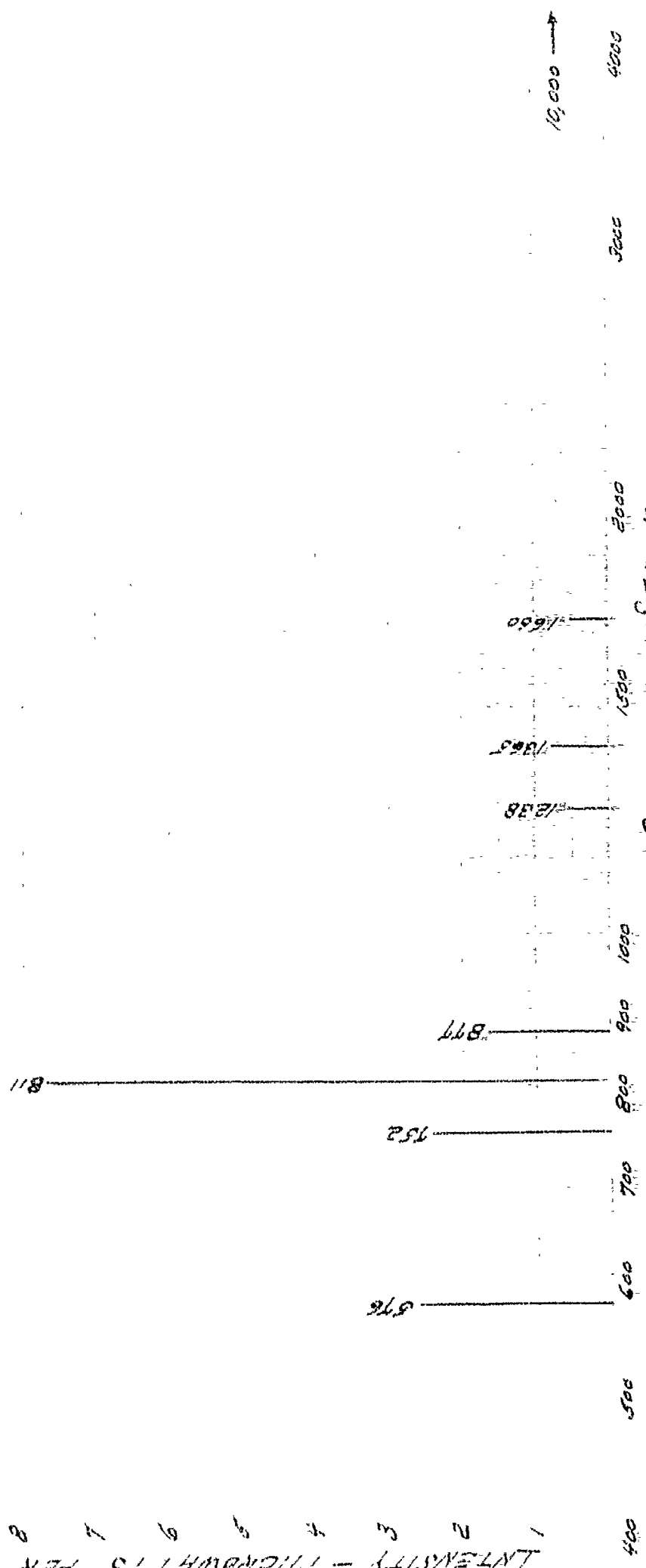

GRAPH SHEET No. 8  
 "WOLF" TONE ANALYSIS  
 SMALL AMPLITUDE  
 NOTE @ 618 2/SEC.

INTENSITY - MICROWATTS PER SQUARE CM

$10 \times 10^{-2}$

1  
2  
3  
4  
5  
6  
7  
8  
9  
0

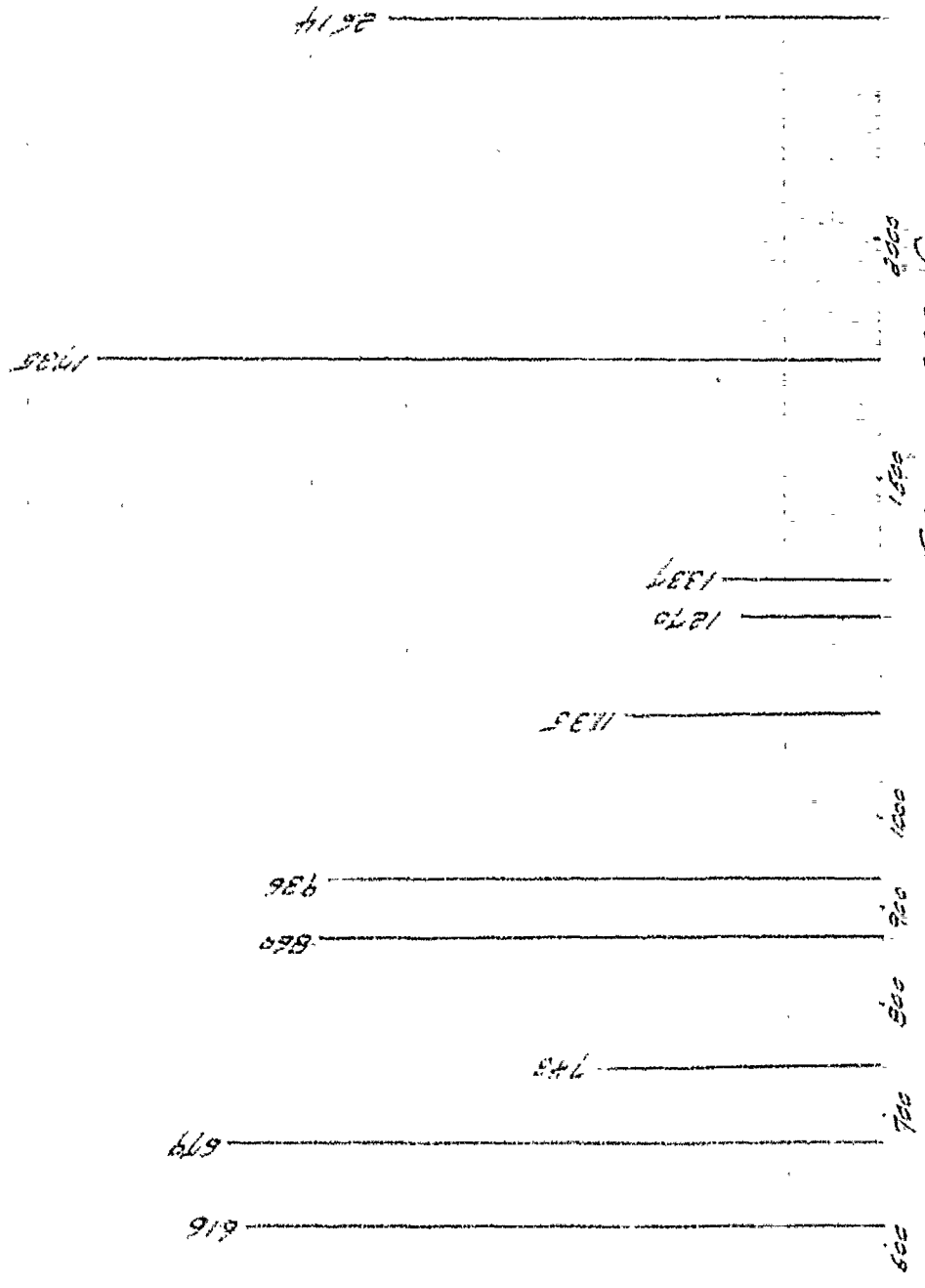

FREQUENCY - CYCLES PER SECOND

15,000  
5000  
4500  
4000  
3500