

2020 UC MET 151b. BattleBot Team “Mamba”

Senior Design III Report

A Baccalaureate thesis submitted to the
Department of Mechanical and Materials Engineering
College of Engineering and Applied Science
University of Cincinnati

in partial fulfillment of the
requirements for the degree of

Bachelor of Science

in Mechanical Engineering Technology

by

Nicholas D’Angelo, Evan Ruthsatz, Daniel Wittmann

April 2020

Thesis Advisor:

Professor Janet Dong, Ph.D.

Table of Contents

Problem Definition	4
<i>Problem Statement</i>	4
<i>Background of the Competition</i>	4
Research	5
<i>Scope of the Problem</i>	5
<i>Current State of the Art – Frame/Armor and Weapon Type</i>	5
<i>Wedge/Box</i>	5
<i>Spinner</i>	5
<i>Drum</i>	6
<i>Conclusions and Summary of Research – Frame/Armor and Weapon Type</i>	6
<i>Current State of the Art – Drivetrain</i>	7
<i>Belt</i>	7
<i>Chain</i>	8
<i>Gear</i>	8
<i>End User</i>	9
<i>Conclusions and Summary of Research - Drivetrain</i>	9
Quality Function Deployment	10
<i>Customer Features</i>	10
<i>Engineering Characteristics</i>	10
<i>House of Quality</i>	11
<i>Product Objectives</i>	13
Design Process and Selection	14
<i>4 Wheels with Medium Weapon</i>	14
<i>2 Wheels with Small Weapon</i>	15
<i>2 Wheels with Large Weapon</i>	16
<i>Complete Final Design</i>	18
<i>Frame System Analysis</i>	20
<i>Max Force Expected Calculations</i>	20
<i>Large 2 Wheel Analysis</i>	24
<i>Final Design Analysis</i>	26
<i>Armor Analysis</i>	29
<i>Final Frame and Armor Selection Overview</i>	31
<i>Drivetrain System</i>	32
<i>Drivetrain System Calculations</i>	33

<i>Weapon System</i>	35
<i>Weapon System Calculations</i>	39
<i>Electronics</i>	40
<i>Estimated Total Design Weight</i>	41
Proposed Fabrication and Assembly	42
<i>Frame and Armor</i>	42
<i>Drivetrain</i>	42
<i>Weapon System</i>	42
Planned Testing and Proof of Design	43
<i>Testing</i>	43
<i>Proof of Design</i>	43
Project Management	44
<i>Bill of Materials</i>	44
<i>Final Budget</i>	44
<i>Final Schedule</i>	45
References	46
Appendices	47
<i>Appendix A: Parts and Sources</i>	47
<i>Appendix B: BattleBot Survey Sample</i>	52
<i>Appendix C: Selection Matrices</i>	53
<i>Appendix D: 15 lb Technical Regulations for Xtreme BOTS Regional Competitions</i>	54
<i>Appendix E: Mechanical Drawings</i>	60

Problem Definition

Problem Statement

To design and manufacture a 15lb. BattleBot that will compete in the Xtreme STEM Collegiate Clash at Wright State University in the spring of 2020. The frame and armor components will be integrated with other BattleBot components such as the drivetrain, control system, and weapon system which will be created by team members Nick D'Angelo and Evan Ruthsatz.

Background of the Competition

The Xtreme STEM Collegiate Clash is a biannual event hosted at Wright State University and is open to any college students across the country. Xtreme STEM's goal is to "provide hands-on programs that engage students in Science, Technology, Engineering, and Mathematic (STEM) disciplines with career paths in manufacturing." (1) Xtreme STEM is a program of Ohio Robotics Inc., a nonprofit organization dedicated to building a stronger and smarter workforce.

Rules to the Collegiate Clash competition are simple and have been detailed on their website. For example, teams must consist of at least three college students and no adults except for a faculty advisor. Robots must weigh below 15 pounds and must always be on an approved movement restricting block when not in the fighting arena. (2) Matches are conducted in a round robin tournament style in order to determine seeding for the elimination rounds. If neither robot is knocked out during the three minutes, the winner is determined by judges on the criteria of aggression, control, and damage. (2) The competition regulations also give guidelines and restrictions to control and weapon systems that must be followed in order to qualify for the event. For instance, the BattleBots must have a manual disconnect which can be reached within sixty seconds to deactivate the bot. Controls must also be operated by a 2.4 GHz Spread Spectrum radio system. (2) Forbidden weapon types include electrical, heat or flammable, hydraulic, and radio frequency jamming. (2) The remainder of these regulations can be found in the Xtreme STEM Collegiate Clash Competition regulations and will be followed by the designers of this BattleBot exactly.

Research

Scope of the Problem

The main goal to overcome is to design and build a viable BattleBot that can compete and excel against other robots constructed by rival schools. The design must weight under 15 pounds and conform to the events guidelines and regulations. 15 pound BattleBots are small compared to other heavier weight class competitions and provided various challenges for success. Robots must be powerful, agile, and durable in order to compete and succeed.

Current State of the Art – Frame/Armor and Weapon Type

The first step in designing a BattleBot is to choose what type of robot you wish to create. BattleBots allow for endless creativity in design but there are some designs that have proven to be very effective in a 15 pound weight class. These designs can be split into four main categories and will effectively dictate the frame and armor system of a battle bot. These categories include the wedge/box, spinner, drum, and crusher. Hybrid systems using multiple methods are also designed as well. All of the varying designs will be described below.

Wedge/Box

Wedge BattleBots are designed with an inclined plane at the front of the robot. These robots are typically very structurally sound due to their box-like frame design and therefore hard to destroy. Unfortunately, wedge designs allow no room for a weapon and will not do much damage to opposing robots. The goal of wedge BattleBots is to outlast their opponent. (3) Designing a robot of this style would allow for maximum concentration in the frame's structural integrity and the armoring but will lack in offense. If the wedge aspect is removed, ample space is available for a weapon to be attached to the box frame. The additional weapon would allow the bot to have a formidable offense and a solid frame to play defense. These designs are also advantageous because they can be driven if flipped over.

Spinner

The spinner BattleBot is also a very effective design. This robot is constantly spinning its frame or a weapon while moving in many directions. As the BattleBot is turning, it is constantly playing offense and defense simultaneously. They can provide immense damage to the competition but at the cost of structural integrity to themselves. (3) Robots designed in this style could possibly provide great results in competition, but the longevity of the structural components can be questionable after multiple matches. The most famous BattleBot utilizing a spinner is Tombstone.



Figure 1: Tombstone

Tombstone received an award for the Most Destructive Robot. It achieved this award by spinning a tipped metal bar (seen in left of Figure 2) at high speeds and utilizing angular momentum to deliver maximum damage at one point on the blade. Tombstone is so effective because the design can deliver a huge amount of damage while allowing for greater structural integrity. This type of weapon also works on defense as well as it does on offense by offering a large area of attack. The downside of this design is that it can be self-destructive, and it can be difficult to make alterations to the BattleBot.

Drum

Arguably the most successful design is the drum. Drum BattleBots implement a large rotating mass at the front as their weapon. The mass at the front of the BattleBot can cause immense damage to the opponent due to its massive moment of inertia. In smaller weight classes, these BattleBots only have two wheels and stand up with the aid of pegs. (3) Drum BattleBots can be vulnerable however because the back end of the design must be lightweight. The frame and armor are much weaker in this area compared to others and subsequently the driver must always be cautious of this weak spot.

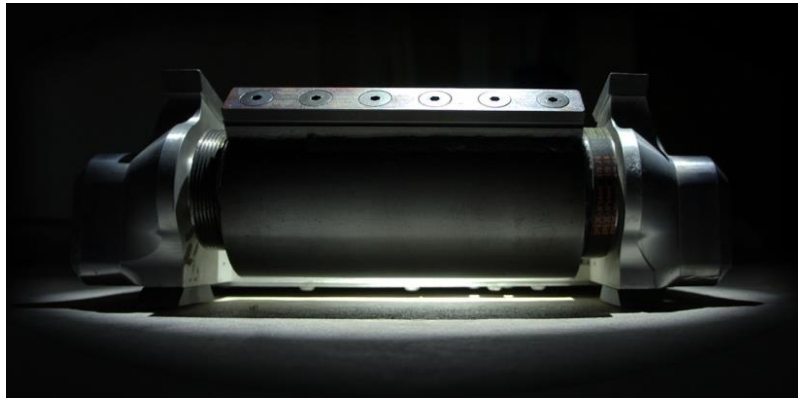

Figure 2: Drum BattleBot

The spinning drum is typically mounted to the front of the bot and spins upwards to knock the competitor into the air. The weapon is very efficient at getting a large amount of energy transferred. The drum is powered by a belt device or chain drive that is connected to an electric motor. This design is also very good at defense since the only part of the bot exposed is the drum. The downside of this design is that you need to get very close to your opponent to make it effective.

Conclusions and Summary of Research – Frame/Armor and Weapon Type

Through the research conducted it can be concluded that the optimal design for the BattleBot's frame would be that of a box design. Although simplistic, the box design allows for all components to be housed effectively and offers great support against attacks from all angles. It allows for various types of weapons to be implemented into the robot as well and can be driven on both sides of the frame. The ideal armoring for the proposed BattleBot would be steel with a high hardness, however other materials such as polycarbonates may need to be selected to save weight. The final recommendation of this report is to construct a box frame for the proposed BattleBot and to implement polycarbonate plating as armor if possible.

Developing an experienced driver by the time of the competition will be prove to be difficult so a weapon will be chosen that provides as much offense as it does defense. This weapon is the spinner. The spinner will be mounted to the front of the BattleBot to create a simpler design and ensure that our attack range will not be limited by the size of the bot.

Current State of the Art – Drivetrain

After conducting research on past UC BattleBot Senior Design projects and professional combat robot teams, it was determined there are many considerations to take into account when designing a drivetrain system. For the intended use of our robot, there are three main drivetrain systems technologies to choose from which are belt, chain, or gearbox. These technologies each boast their own pros and cons depending on the environment they are being used in.

Belt

A belt drive system is a very commonly used technology in mobility systems. Belts are used to transfer energy from one shaft to another and usually runs over two pulleys (4). There are various types of belt drives such as flat belt, v-belt, rope drive, and timing belt (4). Each variety can be beneficial to use in an application based on the orientation of the shafts, direction of belt movement, and power requirements. Belt drives offer advantages to other methods which include being cost-effective, simple, noise dampening, and shock absorbent. In BattleBot applications, belts are the most favorable because they allow slippage and the shafts do not need to be perfectly parallel which may become a factor when dealing with contact forces from an opposing robot's weapon (5). Some disadvantages of the belt drive are limited speeds, heavy load on shafts, and short service life. Past BattleBot senior design teams have used belt drives to operate both their weapon and mobility drivetrains. These systems proved to work well to meet the expectations that are expected by a 15 lb BattleBot.



Figure 3: Belt and Pulley

Chain

The next type of technology found in BattleBot drivetrains is the chain drive. Chain drives contain a roller chain that runs along two sprockets that are connected to a driveshaft and a driven shaft. Chain and sprocket systems work similar to a belt and pulley system, with the main difference being that chain drives do not allow any slippage (4). This type can be used when the distance between shafts is too large to use a gear train, which could be the case in the design of a combat robot. Some pros of using a chain system include no slip, constant angular velocity, and more compact with lower stress on shafts. However, chain systems in BattleBots have been a source of failure because there is lack of resistance to brute force. Along with that, chains are also more expensive, require more maintenance, and have a lower load capacity than gear drives (4).



Figure 4: Chain and Sprocket

Gear

When dealing with a small, confined space, the technology of a gear train or gearbox is the most preferred method of movement in a system. Gear drives are able to transmit considerable power over a short distance with a constant velocity ratio (4). This mechanism works by connecting gears to one another with teeth and use gear ratios to transmit power from a driver gear to the driven gear. There are many different types of gears which include spur gears, helical gears, bevel gears, worm gears, screw gears, and planetary. Gear drives are very efficient with a longer service life than the chain and belt drives, and are capable of very high velocity ratios (4). Gear drives can only be used with two shafts that are close in proximity, but fortunately it is likely this is the case in a combat robot. Other disadvantages include a higher cost, higher weight, and a low flexibility. Past BattleBot projects that used gear direct drives have proven to do well due to the simplicity in its design and low weights. These are some of the things to consider when using a gearbox in a BattleBot design

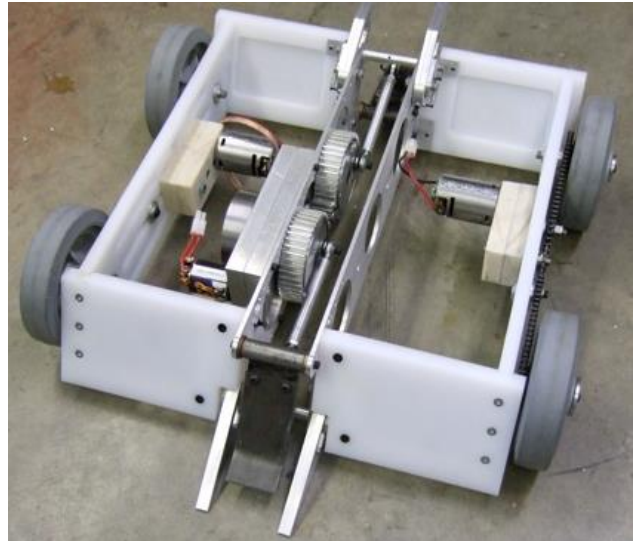

Figure 5: Gear Box

End User

Xtreme Collegiate Clash's 15lb. combat competition will be the end user to this BattleBot along with the members of our team. The University of Cincinnati's BattleBot Club will also be invested in this BattleBot as the primary source of our funding. The customer profile will closely resemble the requirements and regulations of the competition itself. It will also reflect the information gathered by our team members about the most successful BattleBot designs for this specific competition.

Conclusions and Summary of Research - Drivetrain

There are many options to choose from when it comes to creating a 15 lb. BattleBot. Each type of technology and component have their own set of pros and cons which need to be taken into consideration. From looking at previous University of Cincinnati Senior Design Projects, the most common configurations were to have two wheels that were driven with a gearbox and a belt driven weapon. This setup gives a simplicity to the drivetrain which allows for less weight and more flexibility in frame design. The biggest challenge for designing this BattleBot will be to maintain the weight requirement.

Quality Function Deployment

Customer Features

The following is a list of customer features developed by the team in order to gain information by surveying others. The survey was done on a 1 to 5 answering scale. This list does not have any ranking.

1. Low Total Investment Cost
2. Simple Ease of Operation (of BattleBot)
3. High Overall Efficiency (of BattleBot)
4. Effective Weapon Design
5. Strong Frame Durability
6. High Armor Strength
7. Reliable Safety Measures
8. Agile Drivetrain System

Engineering Characteristics

The following is a list of engineering characteristics determined by the team in order to satisfy the customer features during the design process. This list does not have any ranking.

1. Total Weight (lbs)
2. Frame Material Yield Strength (MPa)
3. Armor Yield Strength (MPa)
4. Armor Hardness (HB)
5. Torque to Wheels (N*m)
6. Battery life (mA*h)
7. Controller Frequency (Hz)
8. Weapon Fatigue Strength (MPa)
9. Torque to Weapon (N*m)
10. Overall Safety Factor
11. Weapon Yield Strength (MPa)



Row #	Max Relationship Value in Row	Relative Weight	Weight / Importance	Demanded Quality (a.k.a. "Customer Requirements" or "Whats")	Column #										
					1	2	3	4	5	6	7	8	9	10	11
Quality Characteristics (a.k.a. "Functional Requirements" or "Hows")					Total Weight (lbs)	Frame Material Yield Strength (MPa)	Armor Yield Strength (MPa)	Armor Hardness (HB)	Torque to Wheels (N*m)	Battery Life (mAh)	Controller Frequency (Hz)	Weapon Fatigue Strength (MPa)	Weapon Yield Strength (MPa)	Torque to Weapon (N*m)	Overall Safety Factor
1	9	10.0	1.0	Total Investment Cost	○	⊖	▲	▲		▲	▲	○	○	▲	
2	9	12.5	1.3	Ease of Operation					⊖	▲	○				
3	9	11.9	1.2	Overall Efficiency	○	○		○	○	⊖	▲	○	○	⊖	
4	9	14.4	1.4	Weapon Design	○							○	⊖	⊖	▲
5	9	13.1	1.3	Frame Durability	▲	⊖									○
6	9	13.1	1.3	Armor Strength	▲		⊖	⊖							○
7	9	11.9	1.2	Safety		○	⊖	⊖	▲			▲	▲	▲	⊖
8	9	13.1	1.3	Drivetrain Mechanism	○				⊖	▲	▲				

Target or Limit Value															
Difficulty (0=Easy to Accomplish, 10=Extremely Difficult)															
Max Relationship Value in Column	3	9	9	9	9	9	3	9	9	9	9	9	9	9	9
Weight / Importance	174.4	279.3	235.0	270.7	278.0	142.7	72.5	207.2	207.2	258.6	200.1				
Relative Weight	7.5	12.0	10.1	11.6	12.0	6.1	3.1	8.9	8.9	11.1	8.6				

Product Objectives

Based on the results of the House of Quality and the surveys conducted the weighted importance of the engineering characteristics are listed below with the highest rank as the most important. Each characteristic has their weighted rank beside them and add to equal 100. These factors will be optimized and focused on throughout the design.

1. Frame Yield Strength (12)
 - a. Material has high tensile strength
 - b. Remains cost effective
2. Torque to Wheels (12)
 - a. Efficient drivetrain mechanism provides proper power to weight ratio
3. Armor Hardness (11.6)
 - a. Material has high Brinell number
 - b. Material that is easy to machine
4. Torque to Weapon (11.1)
 - a. Larger weapon radius provides more torque and damage to opponent
5. Armor Yield Strength (10.1)
 - a. Strong material selection
 - b. Easy to machine material
6. Weapon Fatigue Strength (8.9)
 - a. Material selected can withstand multiple blows over a long period
7. Weapon Yield Strength (8.9)
 - a. Material has a high tensile strength
 - b. Remains cost effective
8. Overall Safety Factor (8.6)
 - a. Use material with high yield strength and low stress
9. Total Weight (7.5)
 - a. Must remain under 15lbs.
 - b. Be as close to 15lbs. as possible
10. Battery Life (6.1)
 - a. Battery must power BattleBot for duration of fight
 - b. Battery must withstand overloads
11. Controller Frequency (3.2)
 - a. Signal must remain constant to BattleBot to continue competition

Design Process and Selection

4 Wheels with Medium Weapon

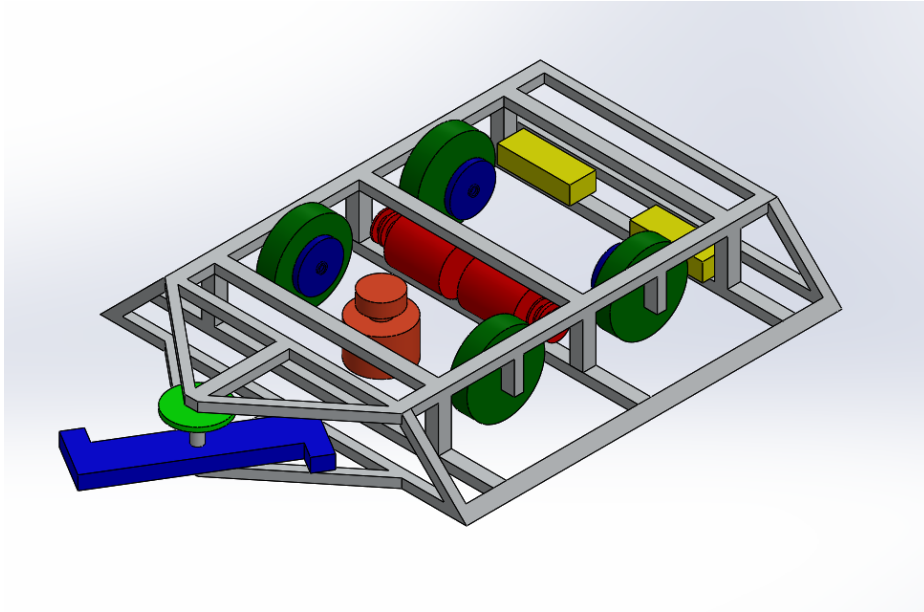

**Armor not shown.*

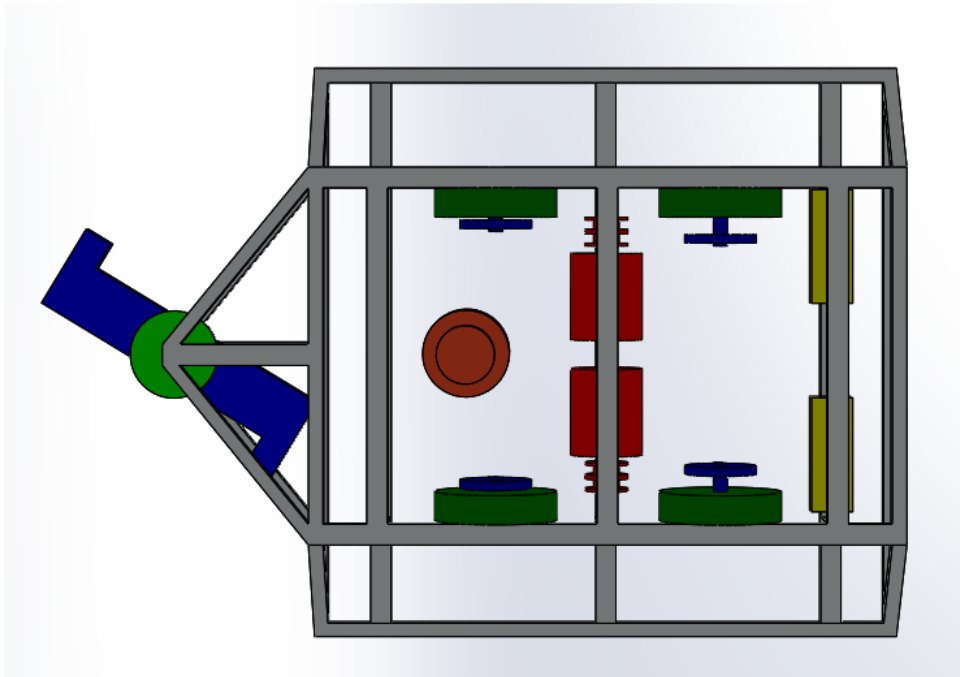

**Armor not shown.*

2 Wheels with Small Weapon

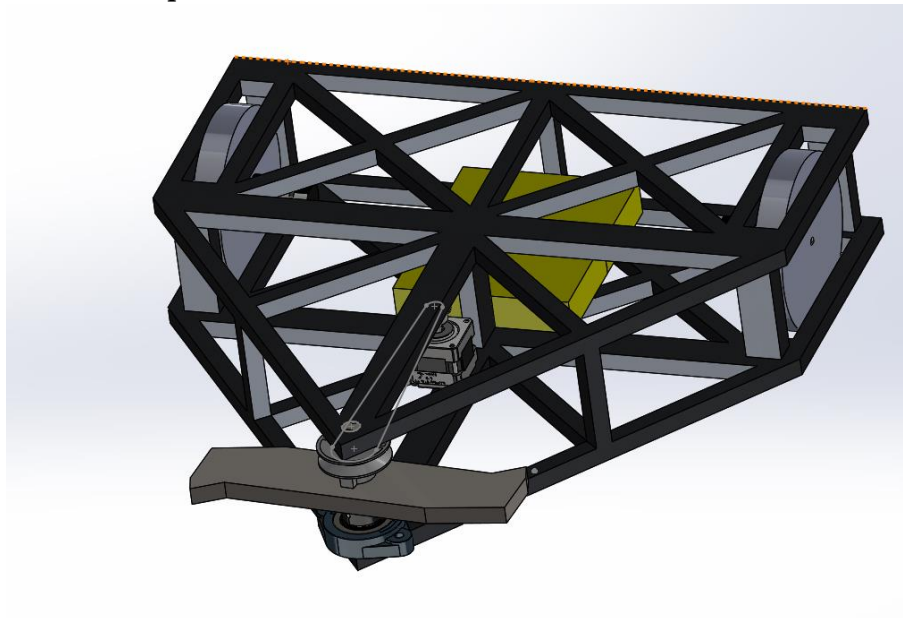

**Armor not shown.*

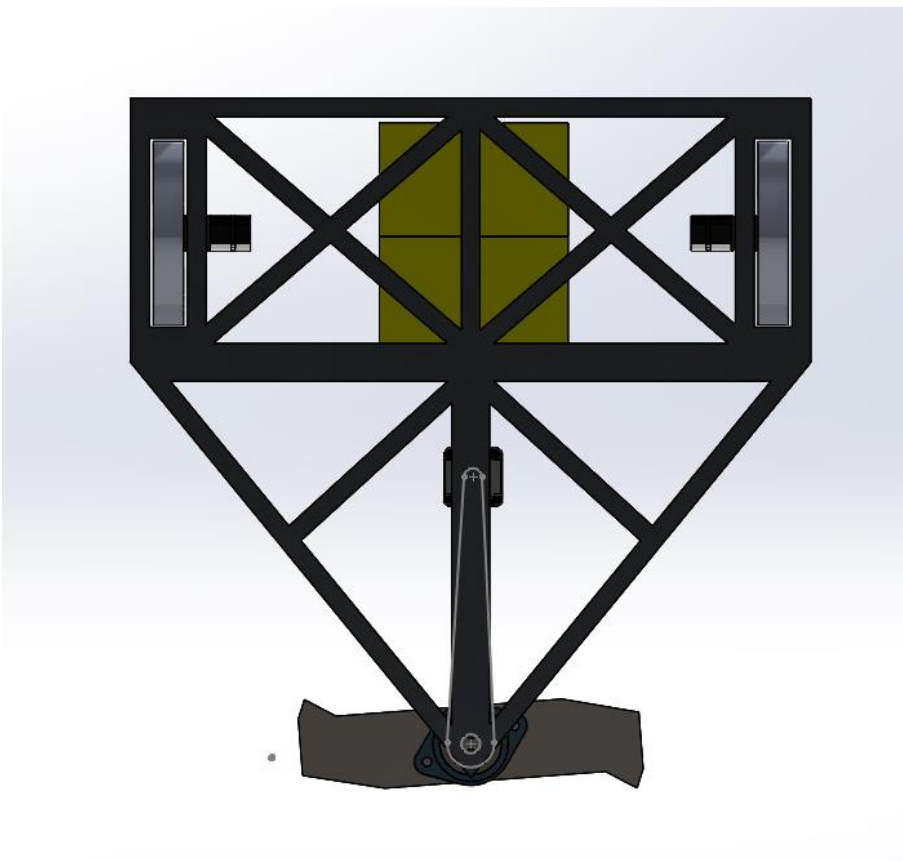

**Armor not shown.*

2 Wheels with Large Weapon

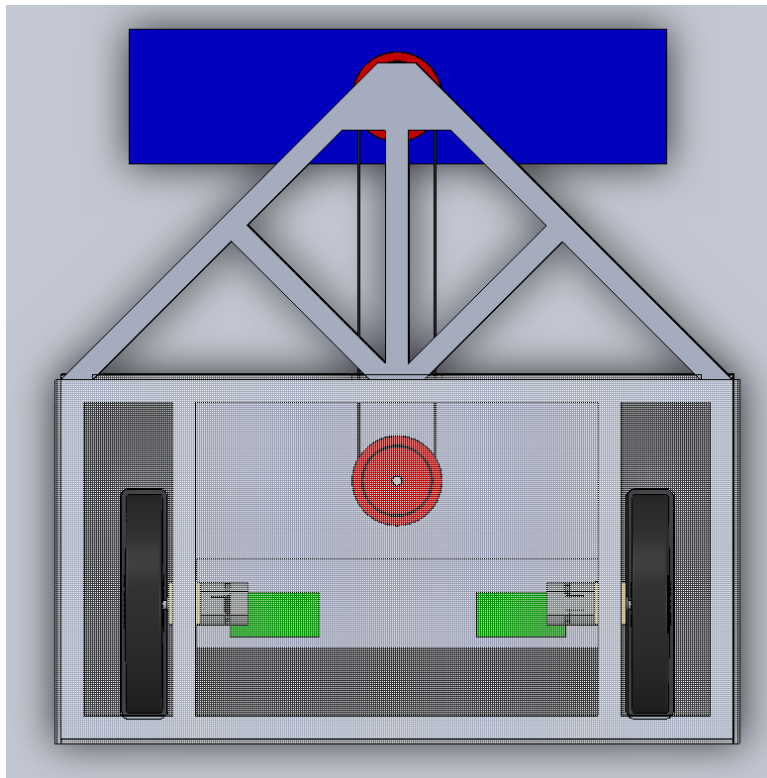
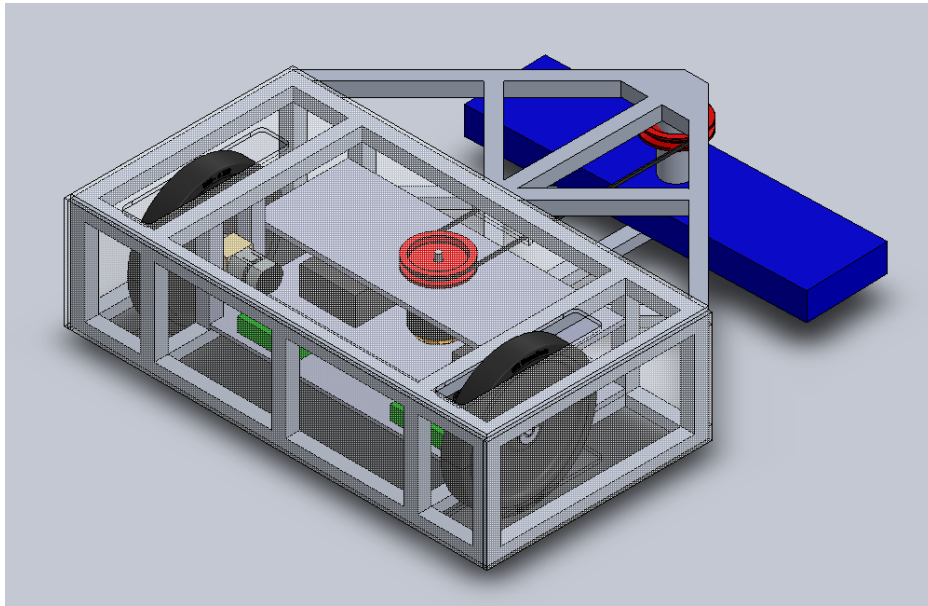

Design Concept Selection Matrix

		Overall Design Concepts					
		4 Wheels with Medium Weapon		2 Wheels with Small Weapon		2 Wheels with Large Weapon	
Criteria	Relative Weight	Rating (1-3)	Weighted Rating	Rating (1-3)	Weighted Rating	Rating (1-3)	Weighted Rating
Weight	15	1	15	3	45	2	30
Cost	10	1	10	2	20	2	20
Manufacturability	15	1	15	3	45	3	45
Reliability	15	2	30	2	30	2	30
Manuverability	10	3	30	2	20	2	20
Defensive Capability	15	2	30	2	30	2	30
Offensive Capability	20	1	20	1	20	3	60
Total	100		150		210		235

Complete Final Design

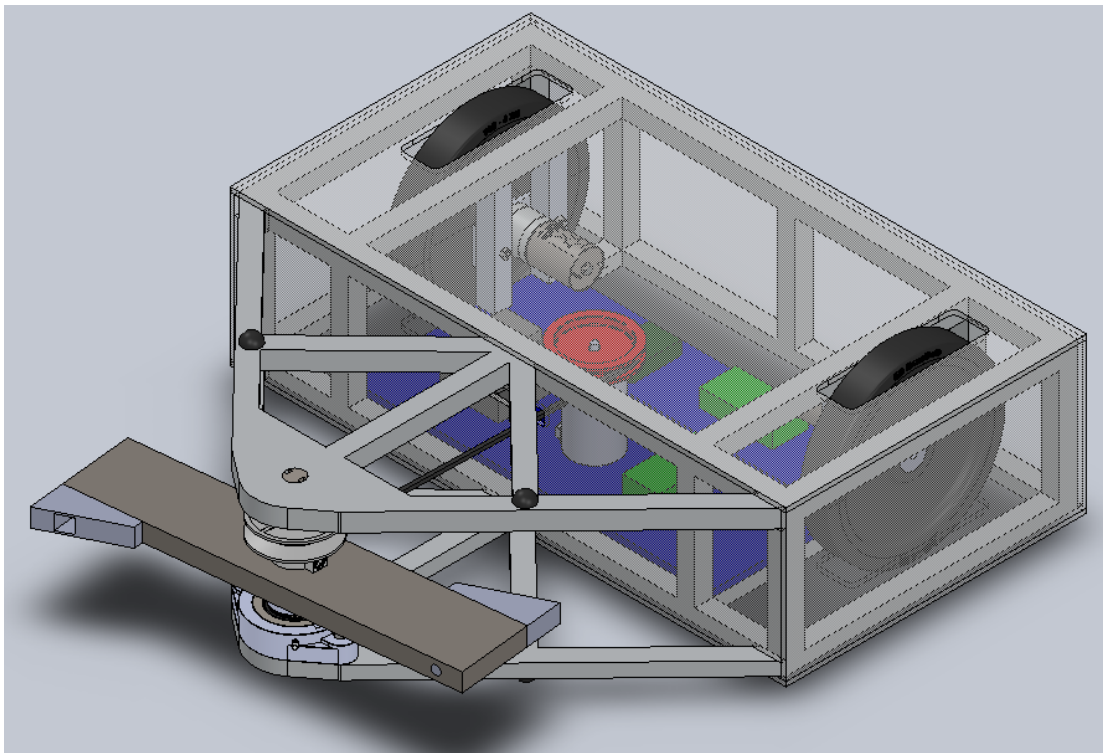
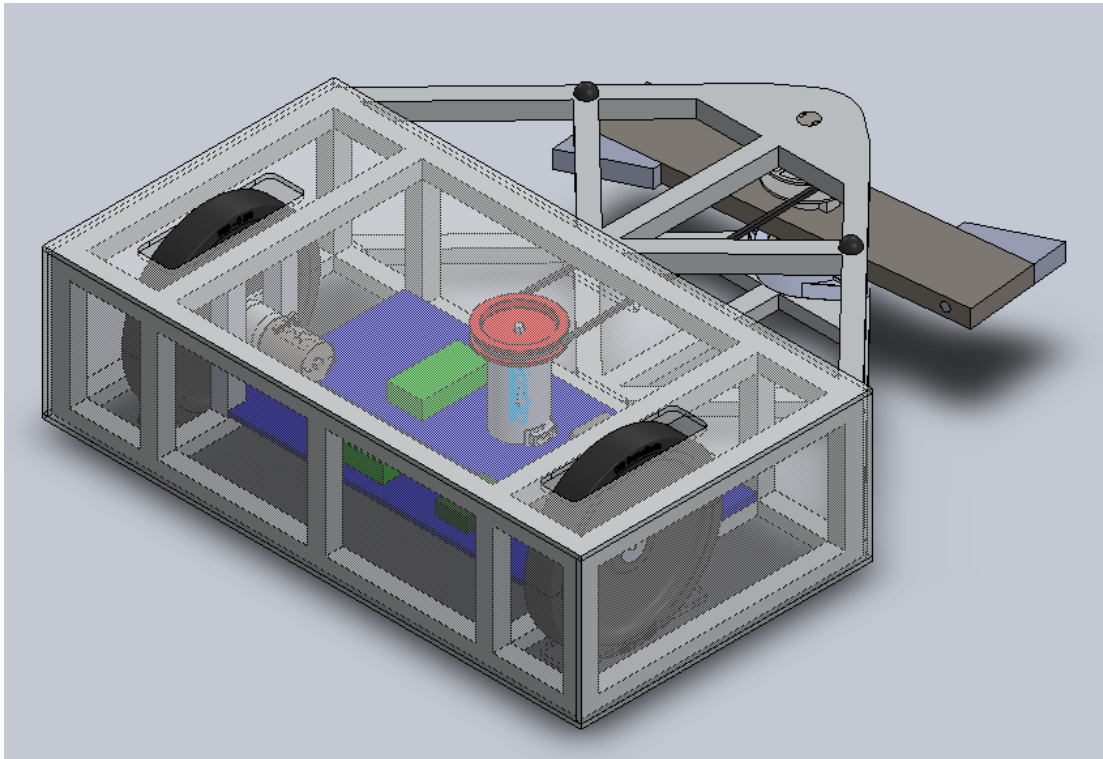

Complete Final Design, cont.

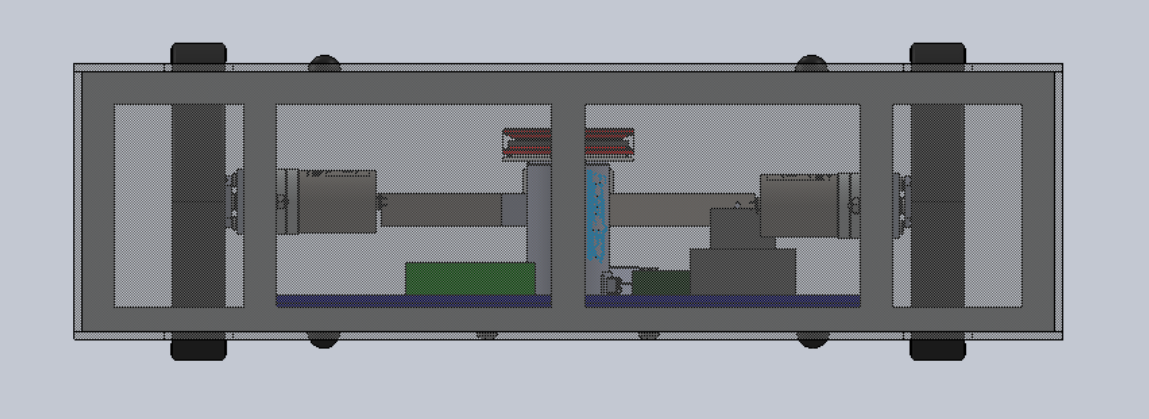
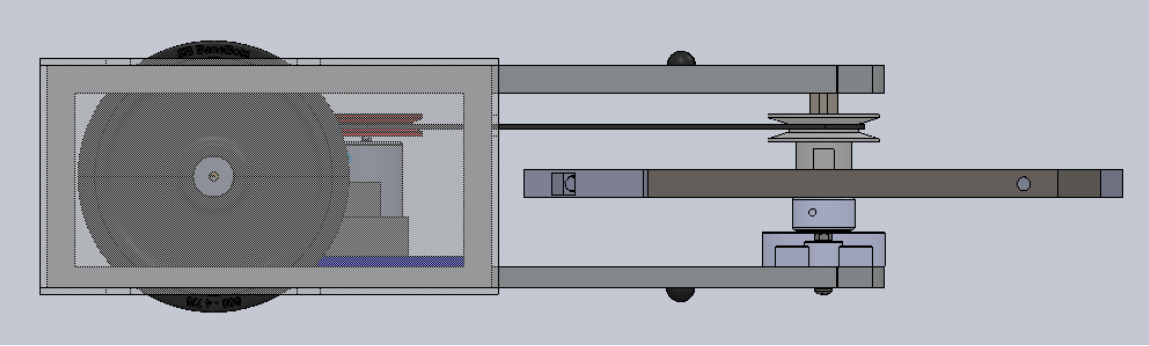
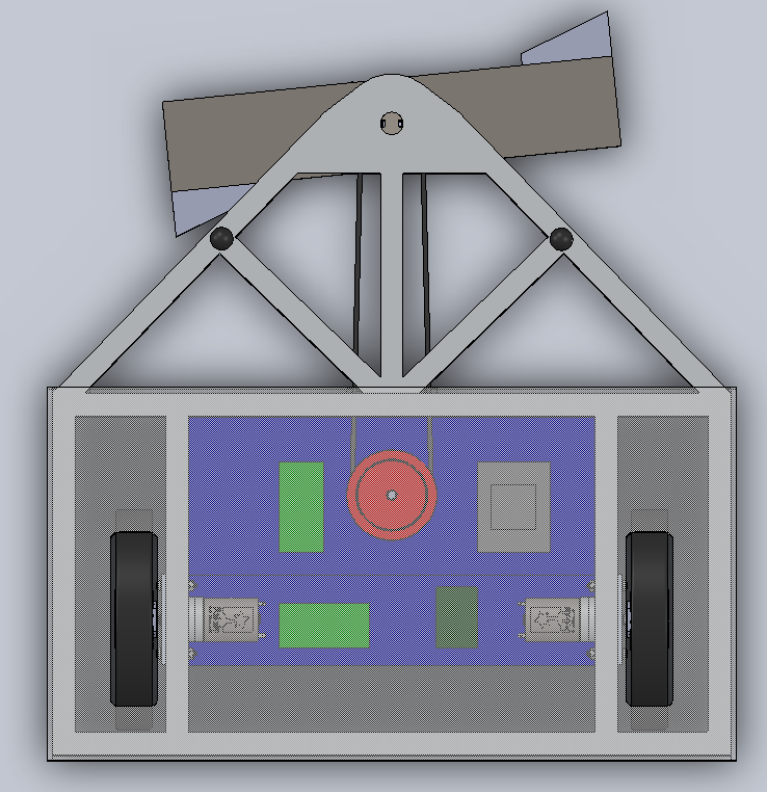

Frame System Analysis

The maximum force the BattleBot would withstand during a competition was calculated. This force was then applied to each designed frame in a “worst case scenario” situation meaning the BattleBot is pinned against a wall and receiving the full impact from an opposing BattleBot. Green arrows in the analysis indicate where the frame is fixed or will not move and the purple or orange arrows indicate where the force is being applied to.

Max Force Expected Calculations

Motor revolution assumption: 200rpm = 209.4 rad/s

Mass of weapon assumption: 1.361 kg

Radius of weapon assumption: .127 m

$$KE_{rotational} = \frac{1}{2}I\omega^2 \quad I = mr^2 = 1.361 \text{ kg} (.127 \text{ m})^2 = .02195$$

$$KE_{rotational} = \frac{1}{2}(.02195)(209.4^2) = 481.23 \text{ Joules}$$

$$KE_{moving \text{ bot}} = \frac{1}{2}mv^2$$

Assume velocity of bot to be 5 m/s

$$KE_{moving \text{ bot}} = \frac{1}{2}(6.804 \text{ kg})(5^2) = 85.05 \text{ J}$$

Speed of bot after combined impact:

$$\frac{1}{2}mv_f^2 = 481.23 + 85.05 = 566.28 \text{ J}$$

$$\frac{1}{2}(6.804)(v_f^2) = 566.28 \text{ J}$$

$$v_f = 12.9 \frac{\text{m}}{\text{s}} \quad \text{High Assumption}$$

$$\text{Momentum} = mv = 6.804(12.9) = 87.7 \text{ kg} \frac{\text{m}}{\text{s}}$$

$$\text{Impulse} = F_{avg}\Delta t = m\Delta v$$

Assume impact time to be 0.1s

$$F_{avg} = \frac{m\Delta v}{\Delta t} = \frac{6.804(12.9)}{.1} = 877.7 \text{ N} = 197.31 \text{ lbf}$$

4 Wheel Analysis

Analysis 1

- 877.7 N (200lbf) applied to the Al 6061 frame
- Max Stress: 30.15 MPa
- Yield Strength: 51.5 MPa
- Safety factor: 1.7

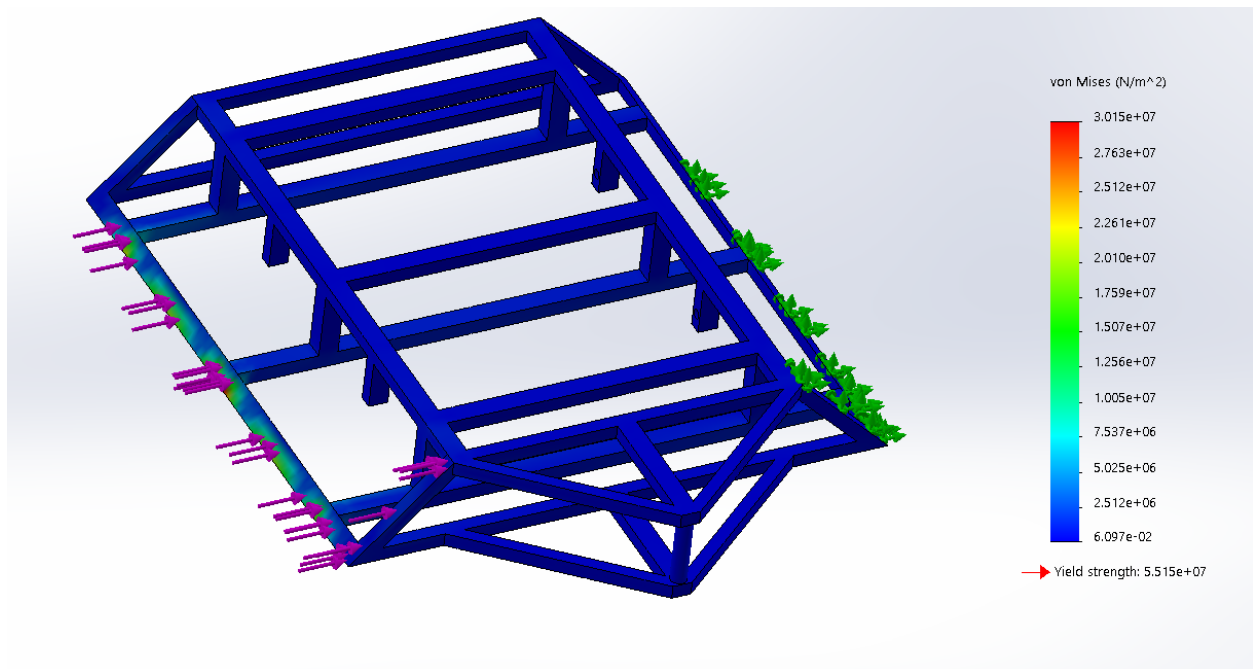

Analysis 2

- 877.7 N (200lbf) applied to the Al 6061 frame
- Max Stress: 55 MPa
- Yield Strength: 51.5 MPa
- Safety factor: .94

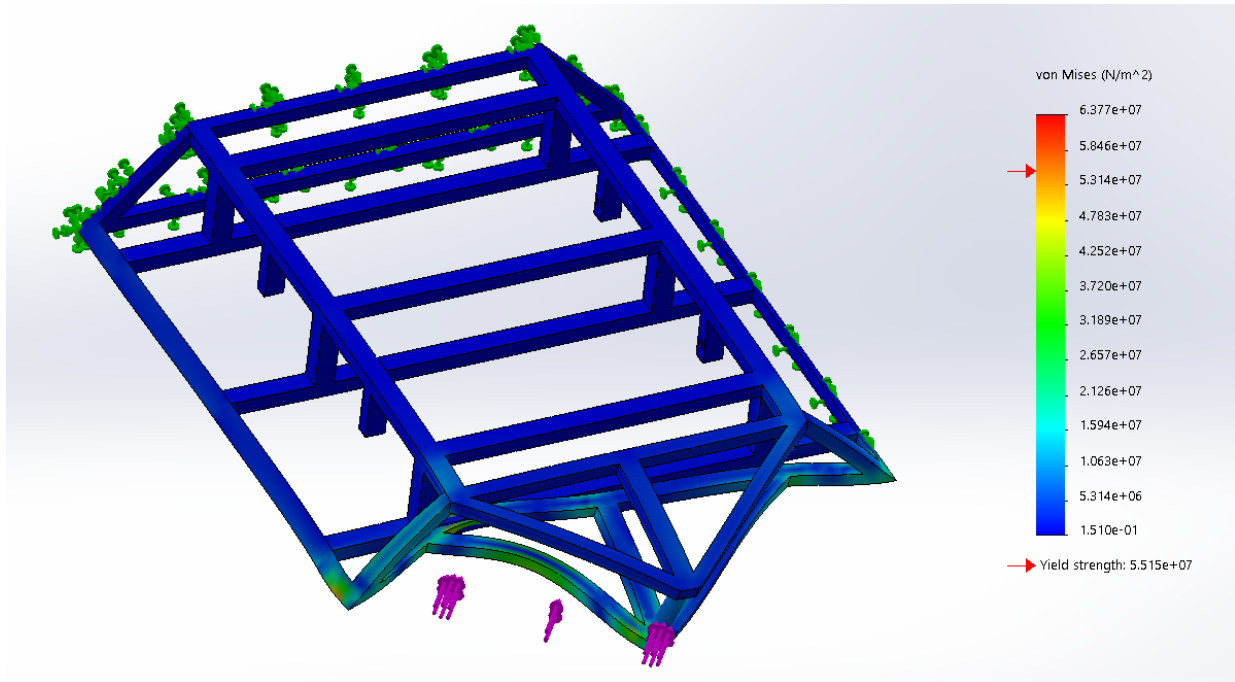

Analysis 3

- 877.7 N (200lbf) applied to the Al 6061 frame
- Max Stress: 56 MPa
- Yield Strength: 51.5 MPa
- Safety factor: .92

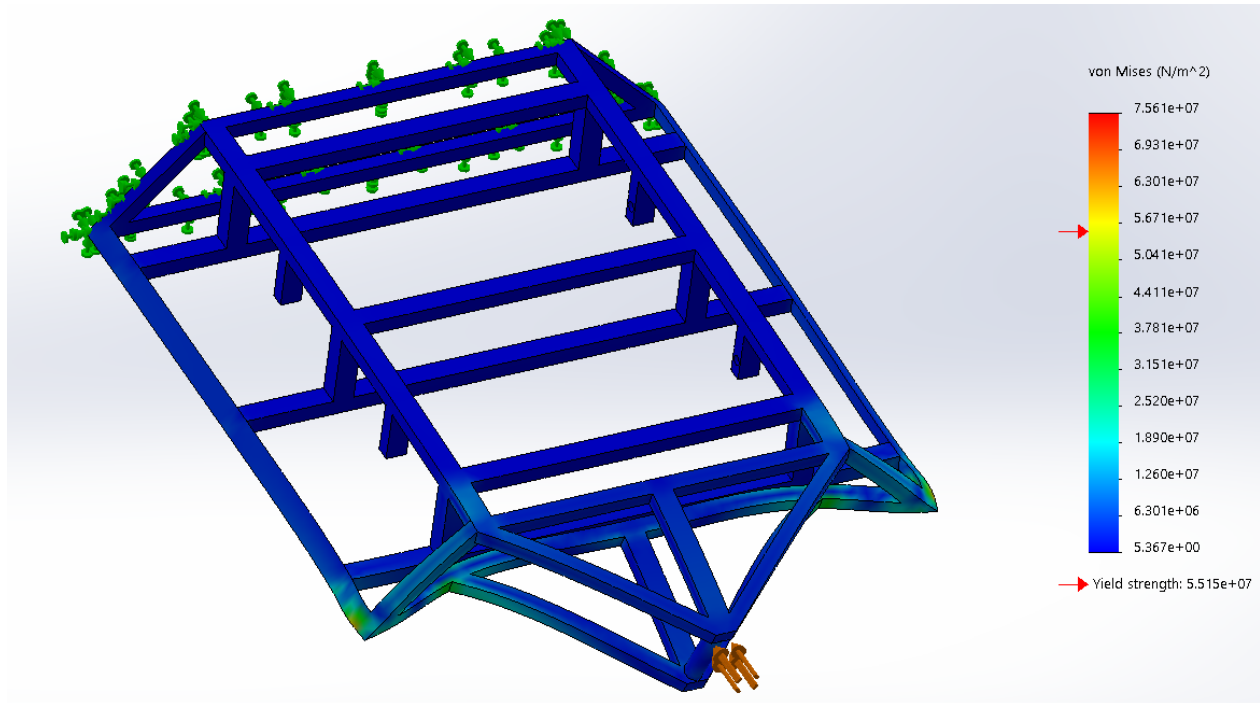

Large 2 Wheel Analysis

Analysis 1

- 877.7 N (200lbf) applied to the Al 6061 frame
- Max Stress: 5.4 MPa
- Yield Strength: 51.5 MPa
- Safety factor: 9.5

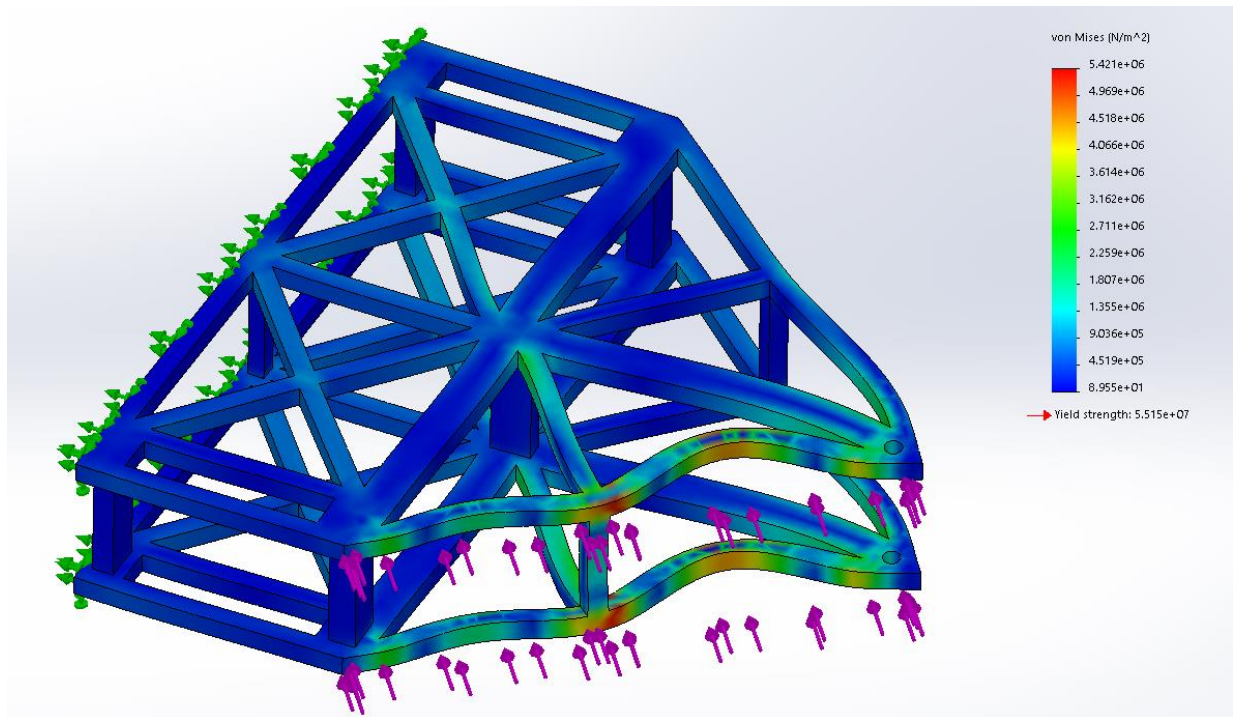

Analysis 2

- 877.7 N (200lbf) applied to the Al 6061 frame
- Max Stress: 14.9 MPa
- Yield Strength: 51.5 MPa
- Safety factor: 3.45

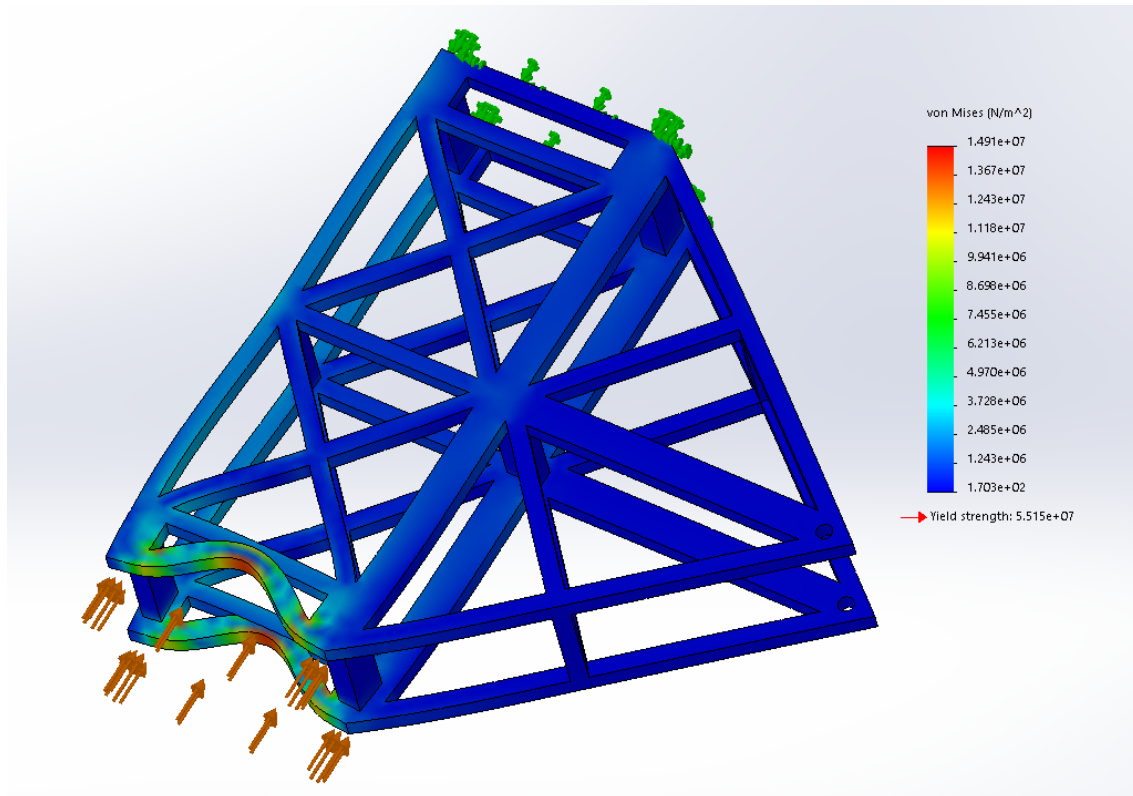

Final Design Analysis

Analysis 1

- 877.7 N (200lbf) applied to the Al 6061 frame
- Max Stress: 11.1 MPa
- Yield Strength: 51.5 MPa
- Safety factor: 4.64

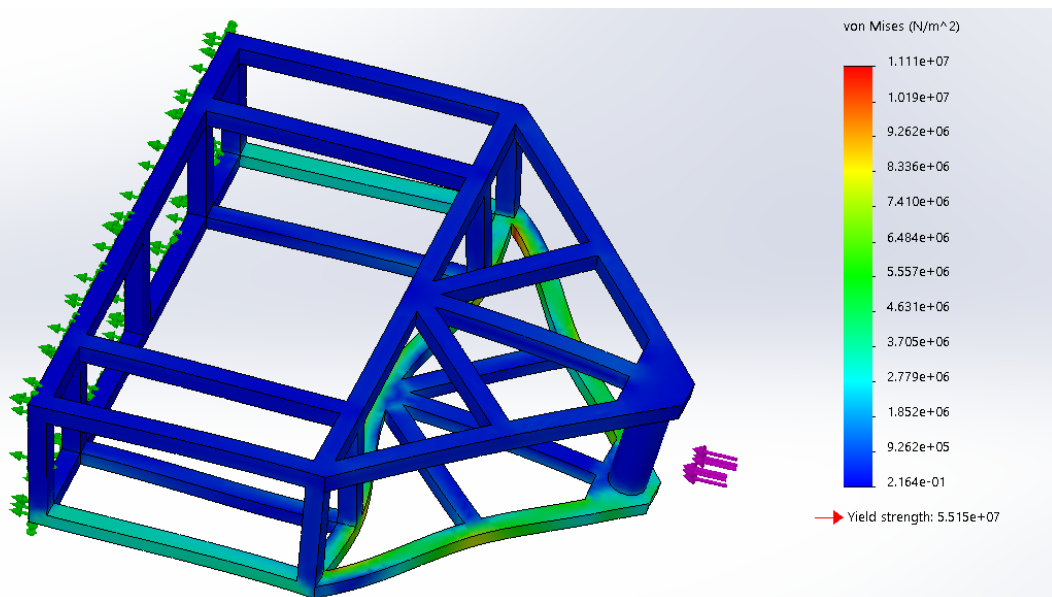
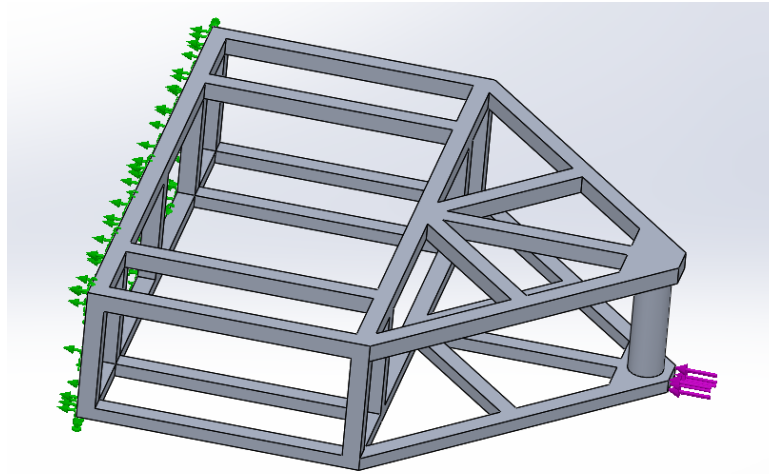

Analysis 2

- 877.7 N (200lbf) applied to the Al 6061 frame
- Max Stress: 15.15 MPa
- Yield Strength: 51.5 MPa
- Safety factor: 3.4

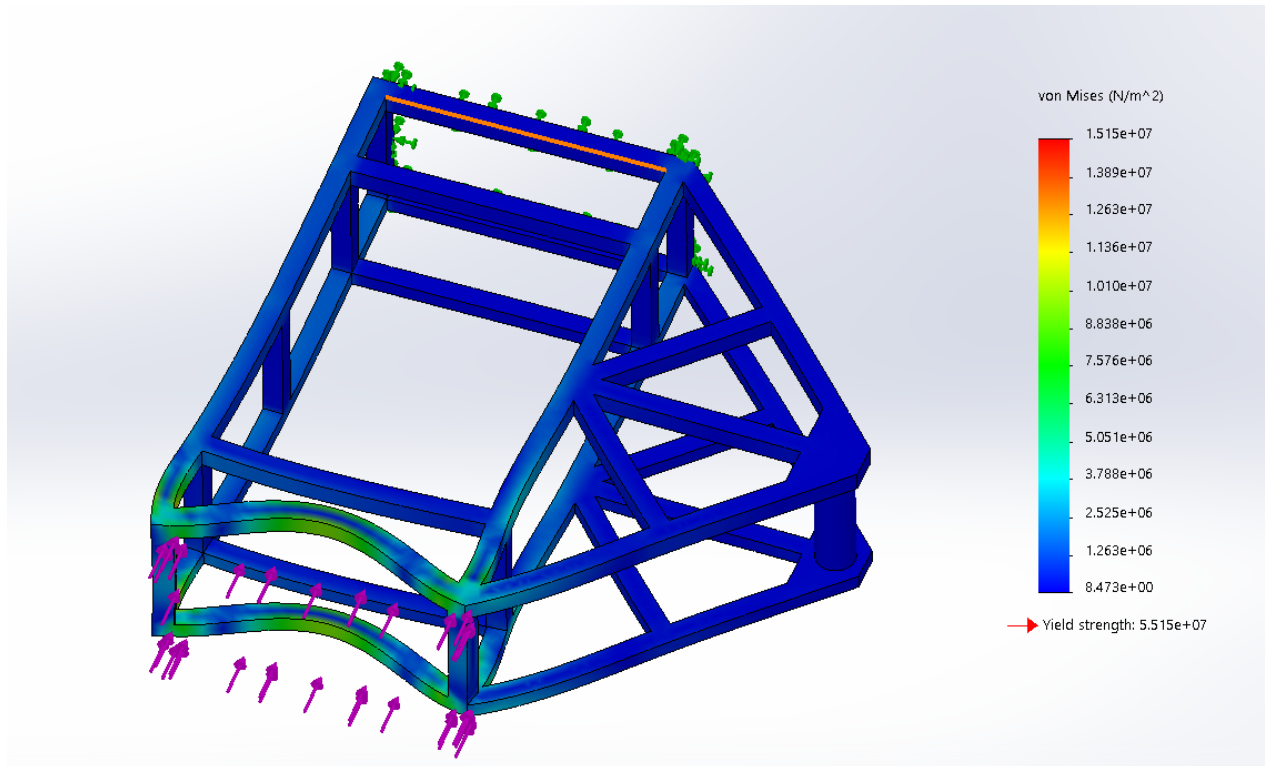

Analysis 3

- 877.7 N (200lbf) applied to the Al 6061 frame
- Max Stress: 11.52 MPa
- Yield Strength: 51.5 MPa
- Safety factor: 4.47

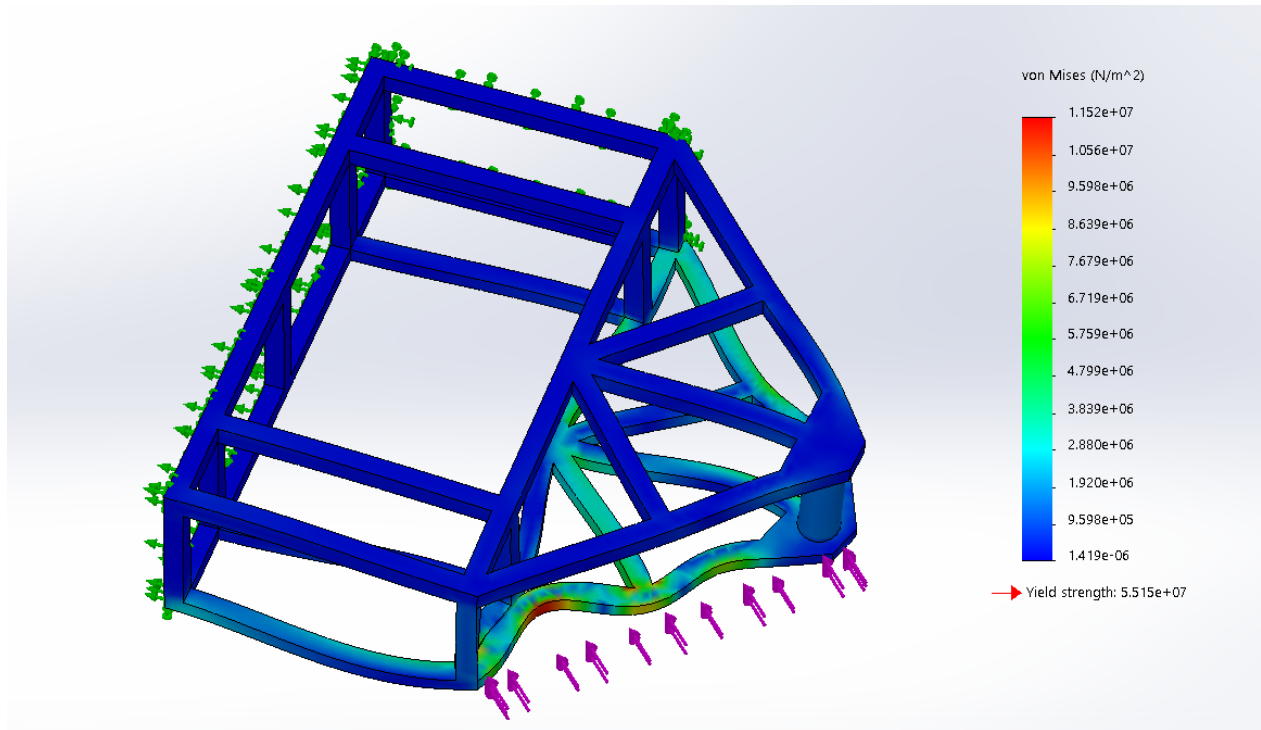

Armor Analysis

Analysis 1

- 877.7 N (200lbf) applied to the top of the polycarbonate sheet
- Max Stress: 13.97 MPa
- Yield Strength: 63 MPa
- Safety factor: 4.5

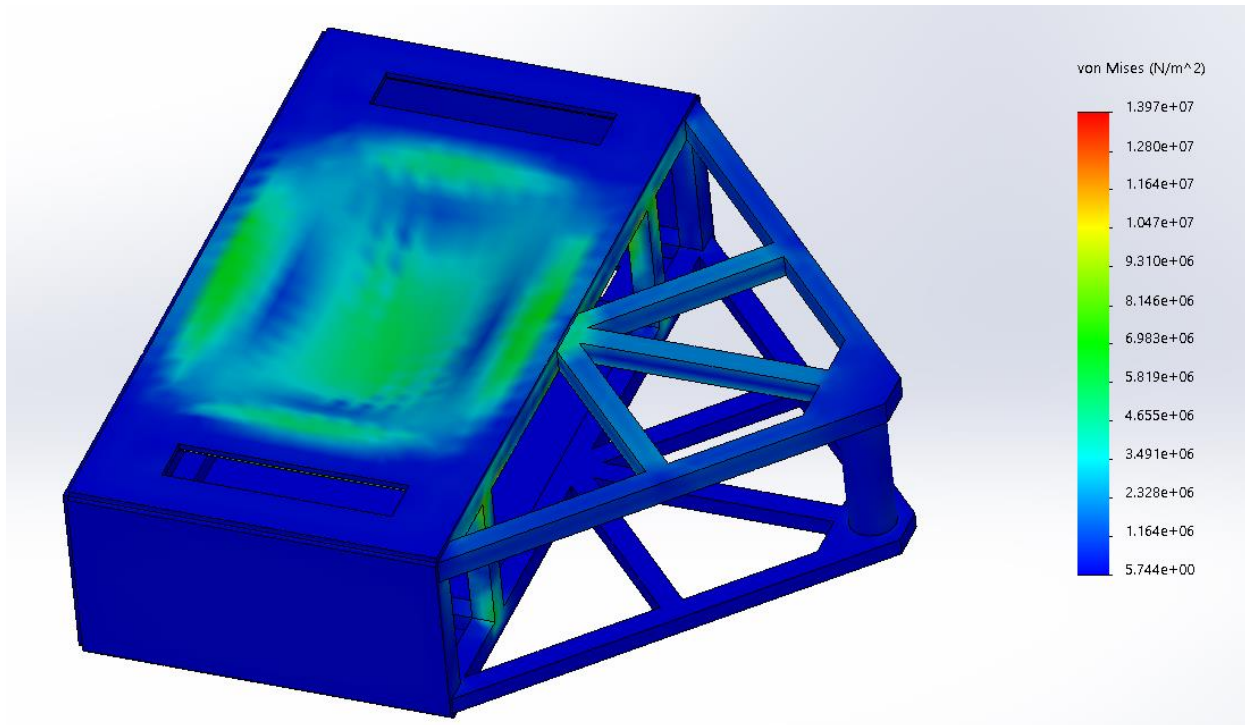

Analysis 2

- 877.7 N (200lbf) applied to the top of the polycarbonate sheet
- Max Stress: 14.1 MPa
- Yield Strength: 63 MPa
- Safety factor: 4.46

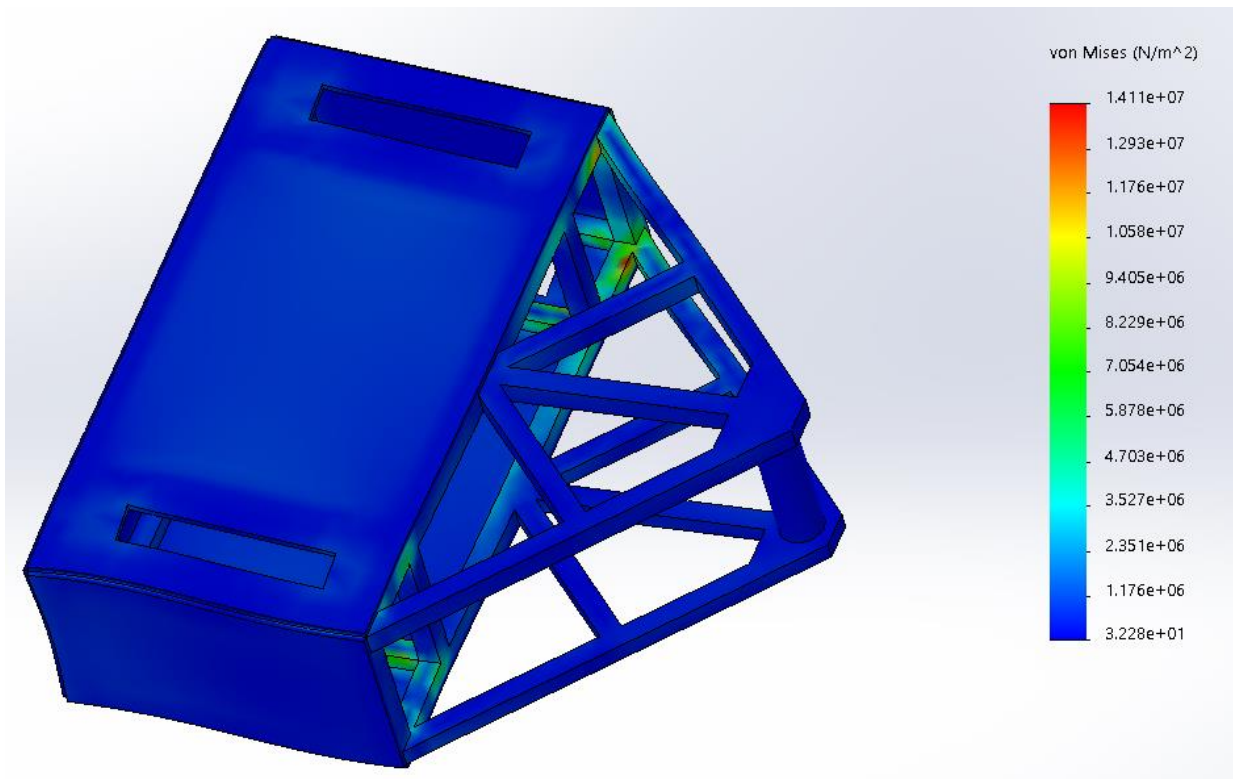

Final Frame and Armor Selection Overview

The final frame and armor plating combination can be seen below. Aluminum 6061 Alloy will be used to construct all of the major frame components. This alloy has a yield strength of 51.5 MPa and will be more than suitable for this application. During each test, the frame yielded a safety factor of 3.4 or above. The frame chosen was also the lightest of the three created and had ample room for components. Implementing enclosed wheels into the design gives the BattleBot more strength and reduces that fragility of its components. Polycarbonate sheeting was chosen as the armor because of its low material density and hardness. This material has a yield strength of 63 MPa and was able to withstand each test conducted with a safety factor or 4.46 or above. Polycarbonate can be cut and modified easily as well which will be beneficial to the construction of the BattleBot.

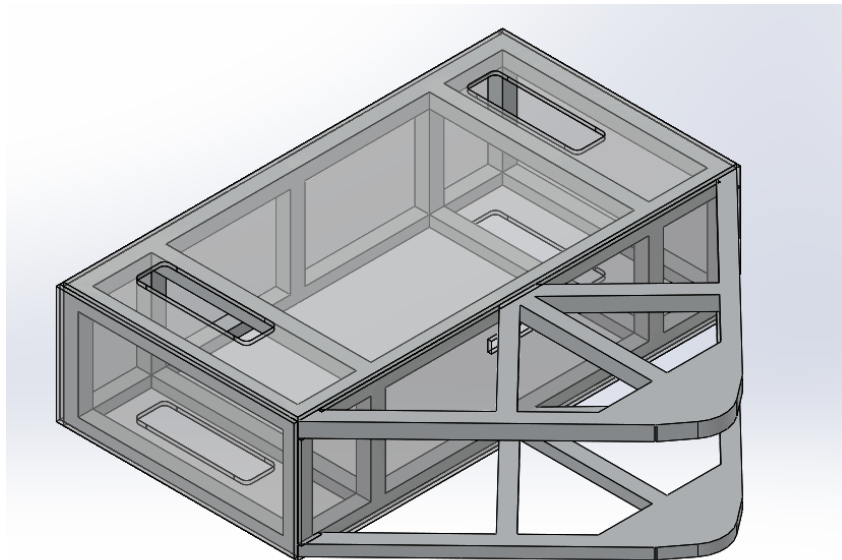
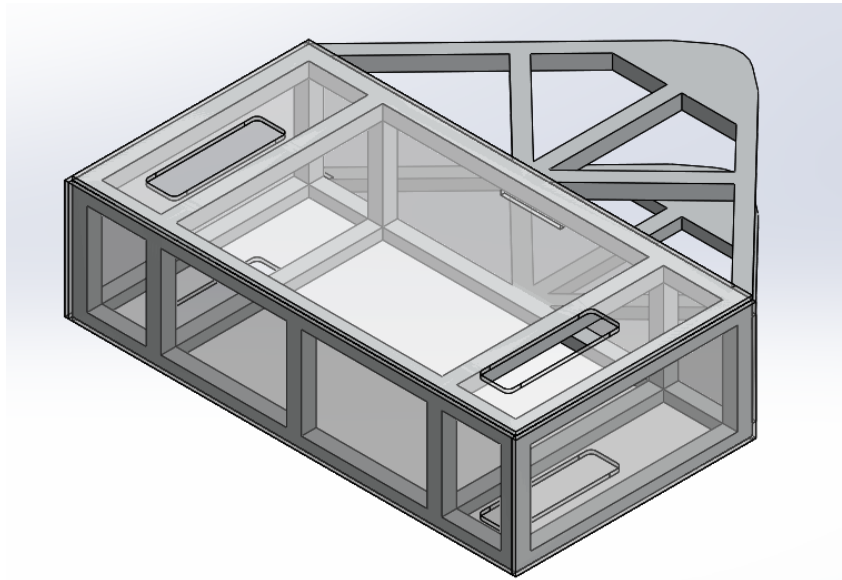

Drivetrain System

The movement drivetrain system for the BattleBot will consist of two 4 7/8" diameter wheels, each being driven with a brushed DC motor with a 210 output RPM and a reduction gearbox with a ratio of 47:1. This setup proved to be the best suited for our robot for multiple reasons such as overall weight, simplicity, and cost level. The motors comes with the gearbox already attached and will run in direct drive. The drivetrain is designed to be symmetrical and will use the same parts to drive each wheel. This will make for an easy to assemble system with a simplified bill of materials. A single DC motor controller will be used to control both of the motors and will communicate with the remote controller operated by a team member. Power for the motors will come from a cell of batteries dedicated solely to the drivetrain so the required voltage levels for operation can be easily maintained. A more detailed list of all the drivetrain components can be found in Appendix A.

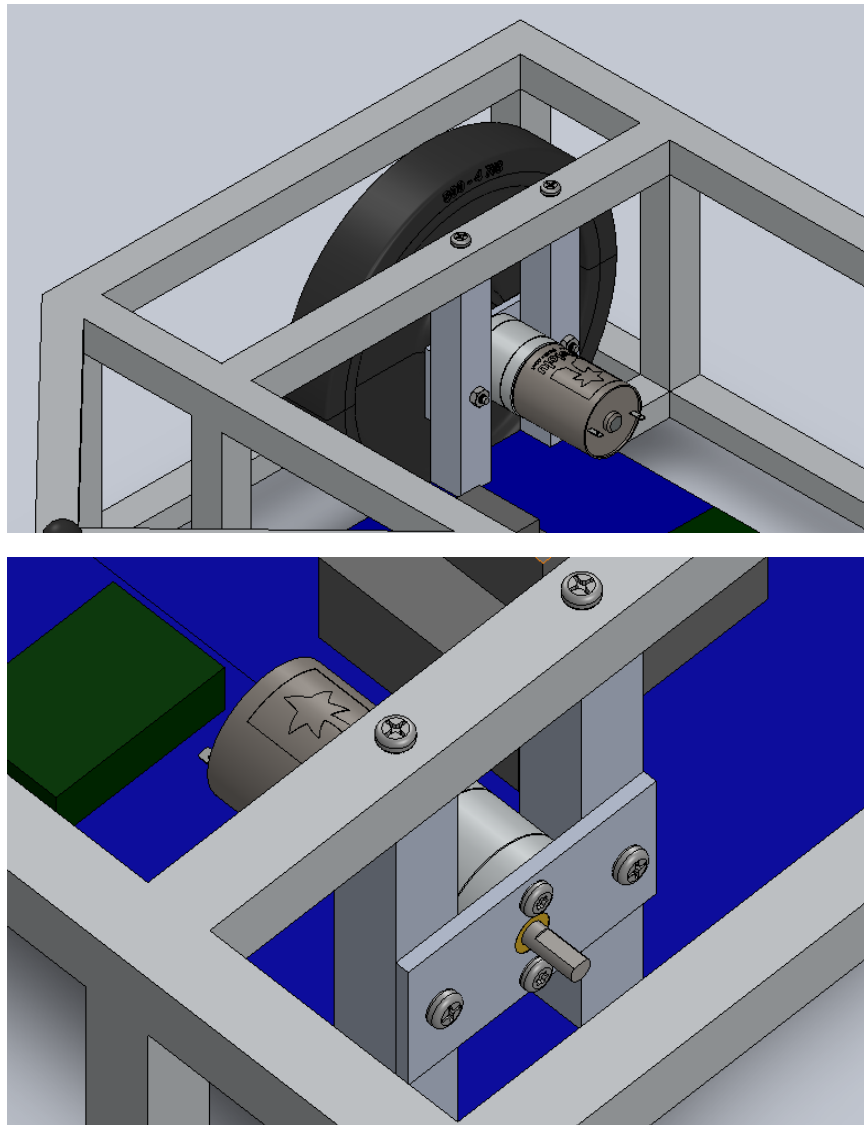

Drivetrain System Calculations

Finding Wheel RPM needed to meet goal of traveling the length of the arena in 2.5 seconds:

Goal: Travel Length of Arena in 2.5 seconds

Length of Arena = 10 feet

$$\text{Wheel Rotations needed} = \frac{\text{Length of arena}}{\text{Wheel Circumference}} = \frac{10\text{ft}}{\pi * \frac{4.875}{12}} = 7.835 \text{ rotations}$$

$$\text{Number of Wheel Rotations per second} = \frac{7.835 \text{ rotations}}{2.5 \text{ seconds}} = 3.13 \text{ rotations/sec}$$

$$\frac{\text{Rotations}}{\text{sec}} \rightarrow \text{RPM} = 3.13 \frac{\text{rotations}}{\text{sec}} * \frac{60\text{sec}}{1 \text{ min}} = 188.04 \text{ Wheel RPM needed to meet goal}$$

Speed of BattleBot:

Pololu Brushed DC Motor Output RPM = 210 RPM

$$\text{Speed of BattleBot} = 4.875 \text{ in} * \left(\frac{1\text{ft}}{12\text{in}}\right) * \frac{210\text{RPM}}{60 \text{ sec}} = 4.46 \text{ ft/sec}$$

$$\begin{aligned} \text{Speed of BattleBot} &= \frac{2 * \pi}{60} * \text{wheel radius} * \text{RPM} = \frac{2 * \pi}{60} * \frac{4.875}{2} * 210 \text{ RPM} \\ &= 53.57 \frac{\text{in}}{\text{second}} \text{ or } \mathbf{4.47} \frac{\text{ft}}{\text{second}} \end{aligned}$$

Turning Radius Calculations:

$$\text{Wheel Spread} = 10.5 \text{ in} = \text{Theoretical Turn Radius}$$

Turn Radius Time:

$$\text{Arc Length of a } 180^\circ \text{ Turn} = \frac{\text{Circumference}}{2} = \frac{\pi * 10.5 * 2}{2} = 2.75 \text{ ft}$$

$$\text{Time to complete } 180^\circ \text{ Turn} = \frac{\text{Turning Arc Length}}{\text{BattleBot Speed}} = \frac{2.75 \text{ ft}}{4.46 \text{ sec}} = 0.62 \text{ sec}$$

Torque Calculations:

$$\text{Single Wheel Load} = \frac{\text{Battlebot Weight}}{2 \text{ Wheels}} = \frac{15 \text{ lb}}{2} = 7.5 \text{ lb}$$

$$\text{Coefficient of friction between Dry Rubber and Dry Steel} = 0.95$$

$$\text{Friction Force on Wheels} = 0.95 * 7.5 \text{ lb} = 7.125 \text{ lb}$$

$$\text{Wheel Friction Torque} = 7.125 * \text{wheel radius} = 7.125 \text{ lb} * \frac{4.875 \text{ in}}{2} = 17.37 \text{ in} - \text{lb}$$

$$\text{Motor Torque: } 0.49 \text{ in} - \text{lb}$$

$$\text{Torque After Reduction: } 0.49 \text{ in} - \text{lb} * (64) = 31.44 \text{ in} - \text{lb}$$

Weapon System

The weapon system will utilize a Racestar 3660 Brushless motor to power the weapon system, it is capable of spinning around 6000 RPM. The weapon system will use a 1:2 pulley reduction so that the robot will maintain control while still delivering a powerful strike. The $\frac{3}{4}$ " fixed bore standard v-belt pulley will have two grooves to allow for two belts to transfer power from the motor to the blade. The blade shape was chosen for its simplicity to manufacture and for a tactical advantage with interchangeability of the tips if more reach is needed based on the opponent. The tips will be secured to the blade body with $\frac{1}{4}$ " flange bolts. The shaft will rotate on a $\frac{1}{2}$ " bore flange bearing. The shaft will utilize a step design to reinforce the center where the most stress will be applied; the larger diameter will be 0.75". The shaft will transfer power to the blade by using two key slots, the safety factor of the blade around the keys is 3.5 but if the design were to change in the future the key may be made larger for added reinforcement because this may be the most vulnerable point on the weapon system. Pieces of metal will be placed and secured in the key slot to prevent the weapon blade from moving vertically after impact.

The weapon system will also utilize a custom-built tensioning system. Two L shaped brackets will have rails on the bottom and be attached to the frame with bolts. The top of each bracket will have a roller on it which will be in contact with the belt a spring will attach to each of the brackets maintaining tension on the belts so they remain in contact with the pulleys after contact.

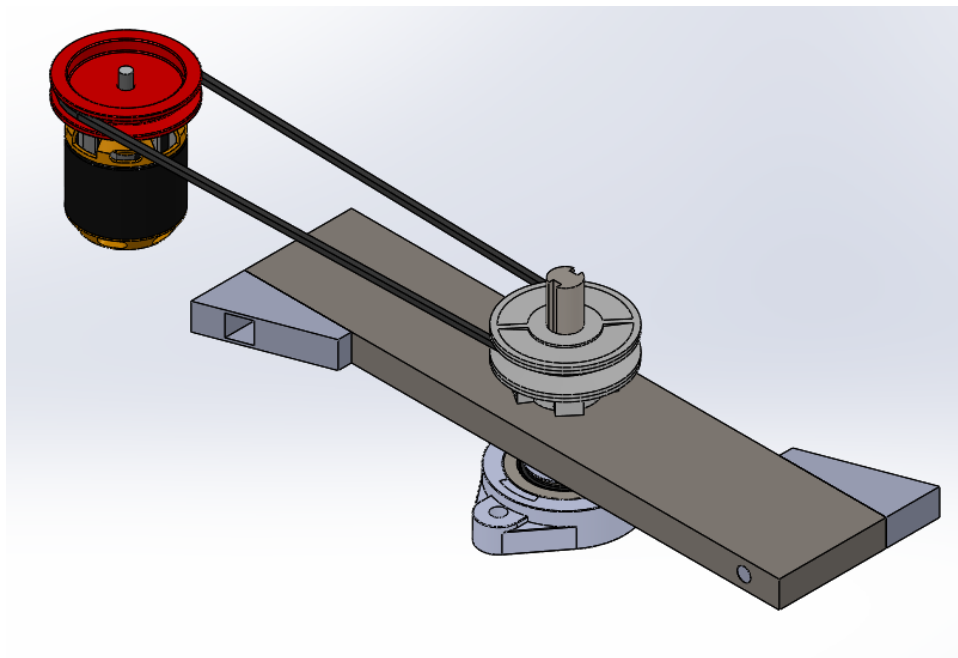

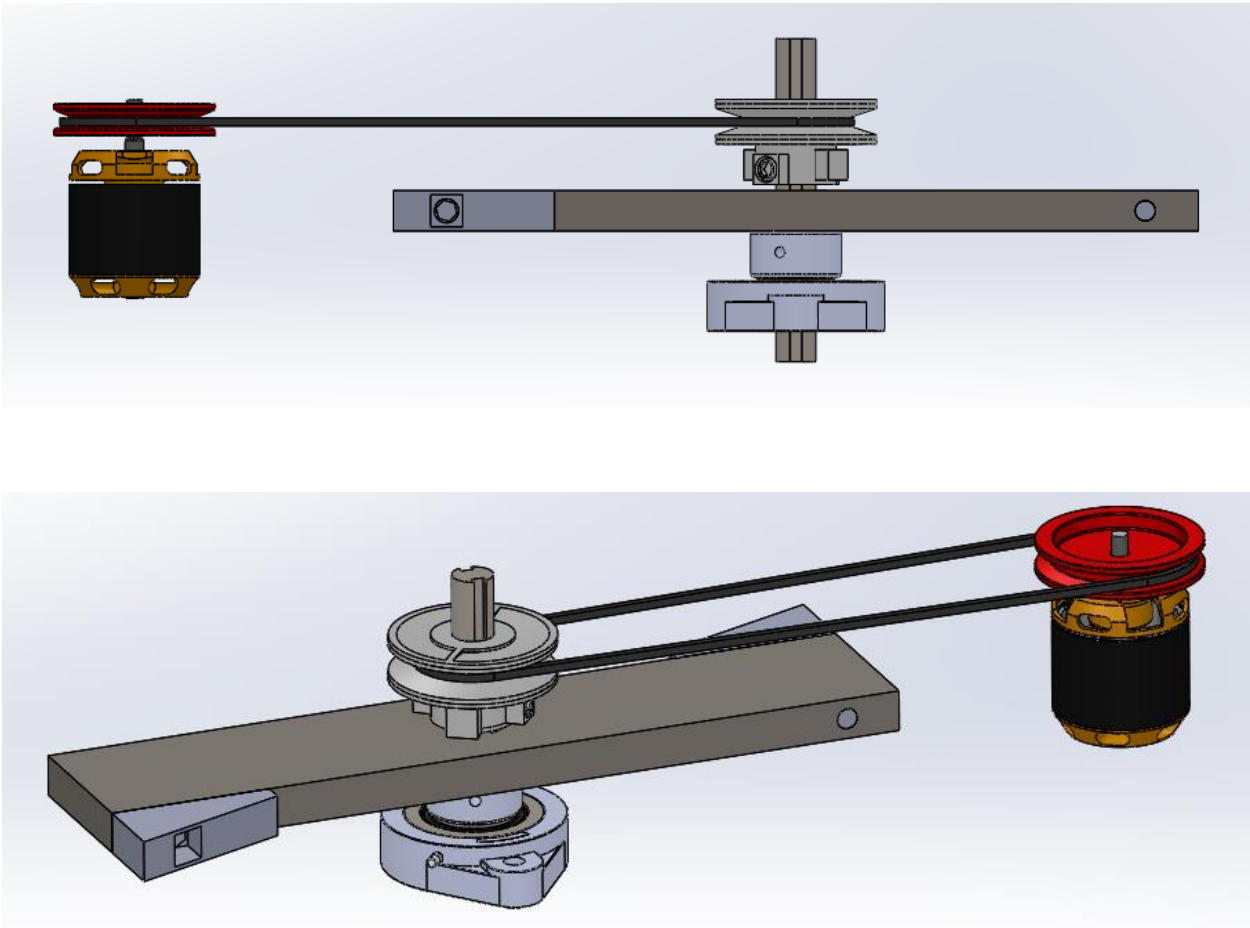

Weapon System Analysis

Analysis 1

- 359.6 N applied to tip of blade made out of 1010 Hot Rolled Steel
- Max Stress: 51 MPa
- Yield Strength: 180 MPa
- Safety factor: 3.5

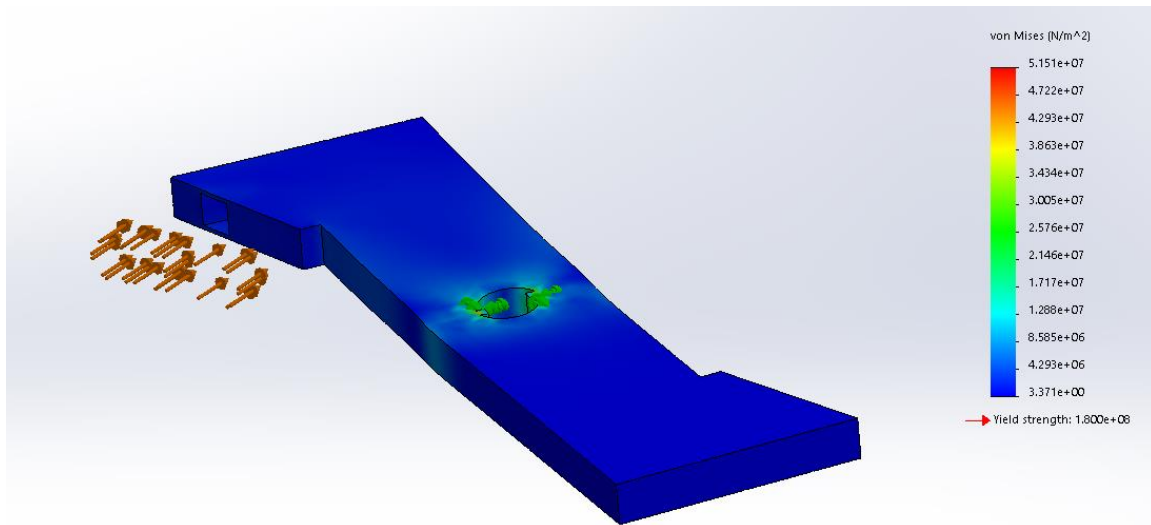

Analysis 2

- 359.6 N applied to key seat of shaft made of 1137 Cold Drawn Steel
- Max Stress: 33.78 MPa
- Yield Strength: 180 MPa
- Safety factor: 5.32

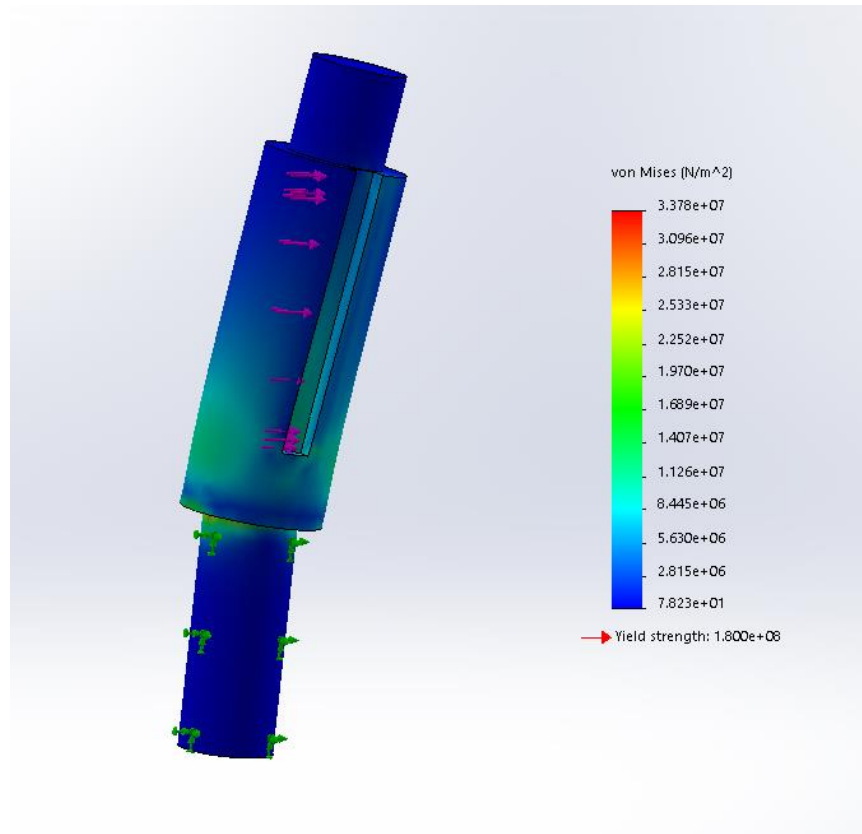

Weapon System Calculations

$$\text{Motor Torque} = \frac{\text{Rated Motor Amperage} * \text{HP Constant}}{\text{Rated Motor RPM}}$$

$$\text{Watts Consumed} = \text{Rated Motor Voltage} * \text{Rated Motor Amperage}$$

$$R_{\text{Motor}} = 0.078 \Omega$$

$$I_{\text{no-load}} = 0.8 \text{ A}/10\text{V}$$

$$\text{Rated Motor Amperage} = 60 \text{ A}$$

$$\text{Max Continuous Power} = 880 \text{ W}$$

$$\text{Max Horse Power} = \frac{880\text{W}}{746 \frac{\text{W}}{\text{HP}}} = 1.18\text{HP}$$

$$\text{Power (watts)} = \text{Torque (Nm)} * \text{Angular Velocity} \left(\frac{\text{rad}}{\text{s}} \right)$$

$$2000 \text{ RPM} = 207.24 \frac{\text{rad}}{\text{s}}$$

$$880\text{W} = \text{Torque(Nm)} * 207.24 \frac{\text{rad}}{\text{s}}$$

$$\text{Torque} = 4.24 \text{ Nm}$$

$$\text{Torque} = \frac{\text{HP} * 5252}{\text{RPM}} = \frac{1.18\text{HP} * 5252}{2000\text{RPM}} = 3.09 \text{ Nm}$$

$$.5I\omega^2 = .5mv^2 = .5 * .127\text{kg} - \text{m}^2 * 207.24 \frac{\text{rad}}{\text{s}} = .5 * 1.37\text{kg} * v^2$$

$$v = 26.24 \frac{\text{m}}{\text{s}}$$

$$I = mr^2 = 1.37\text{kg} * .127\text{m}^2$$

$$\text{Impulse} = F_{\text{avg}} * (\Delta t) = \left(1.36\text{kg} * 26.24 \frac{\text{m}}{\text{s}} \right) * (0.01\text{s}) = 359.6 \text{ N}$$

$$\text{Impulse with Safety Factor 2} = 719.2 \text{ N}$$

Electronics

Components for the electronic system will consist of two 1500mAh batteries. An electronic speed controller (ESC) will be attached to a brushless motor to drive the weapon. The two brushed motors powering the drivetrain are operated using a motor controller. The ESC and motor controller both connect to a 2.4 GHz receiver which receives signals from a remote control. Manual disconnects and running lights are present for both separate systems to coincide with the rules of the competition.

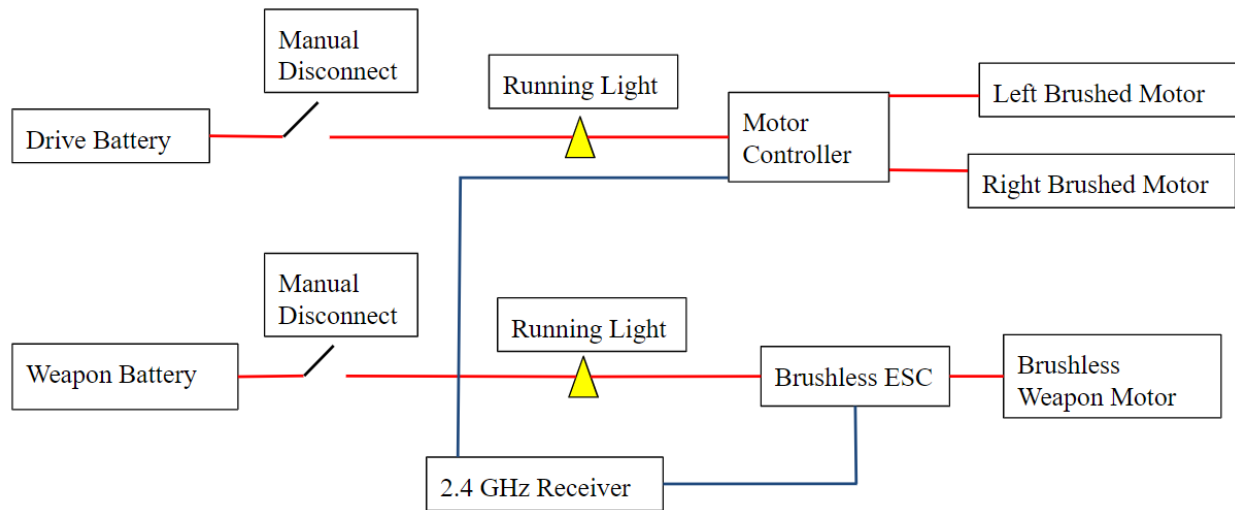

Estimated Total Design Weight

System Components	Weight (lbs)	QTY	Total Weight (lbs)
Weapon	2.5	1	2.5
Weapon Blade & Tips	0.5	1	0.5
Brushless Motor	0.5	1	0.5
Pulley System	0.33	1	0.33
Bearing	0.2	1	0.2
Shaft	0.5	1	0.5
Mounting Hardware	0.2	-	0.2
Drivetrain			
Pololu 47:1 Metal Gear motor	0.4	2	0.8
BaneBot 4 7/8" Wheel	0.32	2	0.64
BaneBot T81 Hub	0.03	2	0.06
Mounting Hardware	0.4	-	0.4
Frame & Armor			
Aluminum 6061 Frame	4.96	1	4.96
Polycarbonate Armor	1	1	1
Hardware	0.5	-	0.5
Electronics			
Brushless Speed Controller	0.15	1	0.15
Brushed DC Motor Driver	0.18	1	0.18
Batteries	0.21	2	0.42
Receivers	0.2	2	0.4
		Total	14.24

Proposed Fabrication and Assembly

Frame and Armor

The vast majority of the manufacturing of the frame will be conducted on a water jet cutter. Water jet cutters utilize extremely high pressure water often mixed with abrasive substances to blast through material. This machine is ideal for the fabrication of the frame because water jet cutters are very efficient at cutting metal sheet and plate. Aluminum 6061 plate 3/8" thick will be cut into two separate pieces, one for the upper half of the top frame and one for the lower half of the top frame. These two frame halves will then be duplicated to create the lower frame. Replacement parts will be created by repeating what has been described. To connect the frame components 1/2" Aluminum 6061 plate will be fabricated using metal band saw into support beams. Holes will be drilled into the frame and support beams in their corresponding locations. Self-tapping screws will be drilled into the holes to connect the frame to its support beams. Holes may then be drilled into the armor in the same location as the self-tapping screws. The screws can be removed, the armor aligned in place, and replaced. These holes and screws will be smaller to keep the weight minimal.

Drivetrain

To secure the drivetrain, two custom parts must be fabricated and added to the BattleBot. The first are vertical supports that will be manufactured out of leftover aluminum material from our frame construction. Each of these four total supports will have a mounting hole machined into the side of them that will be used to secure the second custom part, a mounting plate. This plate will connect the new supports to the brushed motor that drives the wheels and will be made out 10 gauge aluminum sheet metal. There will be five holes machined into this plate. Two holes will utilize the holes pattern on the sides of the support, another two will use two existing mounting holes on the face of the motor, and a fifth hole in the center of the plate will be for the shaft of the motor to reach the wheels. To connect the supports to the frame, a second set of two holes will be drilled and tapped on the top and bottom ends of the support. In order to accommodate these, four total holes (two for each of the four supports) will be drilled through the top and bottom of the frame in line with where the supports will be sitting. The appropriate hardware will be used for each hole to ensure the components will be fastened tightly and will not come lose during combat. All machinery needed for these fabrications can be found in the machine shop at the Victory Parkway Campus at UC.

Weapon System

Fabrication and assembly of the weapon system will be completed in separate parts. The 10" 1144 carbon steel ultra-strength 3/4" rod will be cut in half for two shafts, allowing for a replacement if the other is damaged during battle. The ends of the shafts will be cut to 1/2" diameter to fit into the bearings that will hold the shaft in place. The key seat for the shaft will have to be cut 1/4" wide using a planer or a milling machine on two opposing sides of the shaft. Small shallow holes will also be drilled in for set screws. Small pieces of scrap metal will be cut into shape and secured by the set screws in the key slot of the shaft. For the weapon blade body, it will be cut

from a hot rolled steel flat bar 10" x 7" into 2 blades using the water jet at 1819. At the same time, the center hole in the main weapon block will be precisely into the shaft shape with the two keys. Holes will also be drilled and tapped at each end of the weapon blade body to allow for the attachment of hard, replaceable weapon tips. A 2-bolt flange bearing with ball bearing insert and 1/2" bore diameter will attach to the bottom and bottom of the frame.

Planned Testing and Proof of Design

Testing

Various forms of testing will be conducted on the design when completed. One of the key components to testing is the remote control. Maneuverability and top speed trials will be conducted using the connected remote control. These trials will also help to hone the skills of the remote control operator and aid in the final competition. Another key feature that will be tested is the battery life of the BattleBot. This will help determine if the design can last through an entire fight and if replacement batteries need to be considered. Weapon startup time tests will also be conducted. This would mean the amount of time it takes for the weapon to reach its maximum RPM and give an idea as to when the proper time would be to strike an opponent. To test the durability of the frame and armor, the BattleBot will be struck various times by a previous BattleBot built by the UC BattleBot Club for the same competition. Finally, the damage the weapon can inflict will be determined using the fully operational BattleBot and steel plates.

Proof of Design

In order to prove that the BattleBot constructed works, it will compete in trials and fights against other BattleBots created by the UC BattleBot Club this year. These fights will try to keep damage at a minimum but also help determine weak points in the design. The final proof of design will be the Xtreme BattleBots Competition. If the design succeeds in the tournament and wins its matches the design will prove to be successful.

Project Management

Bill of Materials

P/N*	Description*	Quantity*	Price Per Unit*	Total	Manufacturer
Instructions		School Year*	Team Name*	Total Cost	
This form is to be filled out by a battlebot team to request the parts they need. All fields with a * next to them are required to be filled out.		19-20	Mamba	\$947.06	
CTS-6-48	Clear Polycarbonate Sheet 1/8" thick 48"x18"	1	\$45.00	\$45.00	Acme Plastics
	Acme Plastics Shipping Cost	1	\$39.65	\$39.65	Acme Plastics
	47:1 Metal Gearmotor 25Dx52L mm HP 12V	2	\$21.95	\$43.90	Pololu
	Trossen Robotics Shipping Cost	1	\$15.78	15.78	BaneBots
T81P-496BB	BaneBots Wheel, 4-7/8" x 0.8", Hub Mount, 60A, Black	2	\$3.50	\$7.00	BaneBots
T81H-RM61	T81 Hub, 4mm Shaft	2	\$3.15	\$6.30	BaneBots
	Banebots Shipping Costs	1	\$10.25	\$10.25	BaneBots
	Racerstar 3660 Brushless Waterproof Sensorless Motor 80A ESC For 1/8 1/10 Short Course Rally Car - 2600KV	1	\$67.45	\$67.45	Racerstar
	Racerstar LED Program Card For Racerstar Surpass Rocket ESC	1	\$7.64	\$7.64	Racerstar
SBLF201-8G	2-Bolt Flange Bearing with Ball Bearing Insert and 1/2" Bore Dia.	2	\$15.00	\$30.00	Tritan
5UHH3	3/4" Fixed Bore Standard V-Belt Pulley, For V-Belt Section: 4L, 5L, A, AX, B, BX	1	\$54.00	\$54.00	TB WOODS
	Grainger Shipping Costs	1	\$12.25	\$12.25	
91715A136	Rounded Head Thread-Cutting Screws for Metal Black Zinc-Plated Steel, 10-24 Thread, 3/4" Long	1	\$10.73	\$10.73	McMaster-Carr
6628K33	Easy-to-Machine 1144 Carbon Steel Rod Ultra-Strength, 3/4" Diameter	1	\$9.85	\$9.85	McMaster-Carr
	McMaster Shipping Costs	1	\$15.03	15.03	
6061ASHT500	6061 0.5" Aluminum plate 10"x16"	1	\$30.39	\$30.39	Midwest Steel and Aluminum
(HRFB127)	Hot Roll Steel Flat Bar, Size: 1/2" x 7", Length 10"	1	\$20.54	20.54	Midwest Steel and Aluminum
	Midwest Steel and Aluminum Shipping Cost	1	\$17.31	17.31	Midwest Steel and Aluminum
	Batteries - to be ordered by club through hobby shop	4	\$40.00	\$160.00	
Spektrum AR620	Spektrum AR620 6-Channel RC Sport Receiver	1	\$39.99	\$39.99	
	Amazon Shipping	1	\$5.00	5	
	6061 0.375" Aluminum plate 32"x32"	1	\$249.00	\$249.00	1819 Innovation Hub

Final Budget

Item	Cost
Frame Material	\$400
Armor Components	\$50
Weapon Components	\$300
Drivetrain Components	\$250
Competition Registration Fee	\$50
Miscellaneous Hardware	\$100
Miscellaneous Components	\$50
Total	\$1200

Final Schedule

Schedule 2019/2020 Battlebot Team Nick D'Angelo, Evan Ruthsatz, Danny Wittmann	Problem Statement	Research	QFD	Proposal	Final C concept Decision	Senior Design 2 Presentation	Ordering Parts	Machining & Assembly	SD III Requirements Changed	Programming	Testing and Redesign	Tech Expo (Cancelled)	Competition (Cancelled)	SD III Revised Due Date	Final Presentation (Cancelled)
	Senior Design 1														
August	8/14/2019														
September		9/19/2019													
Senior Design 2															
October			9/27/2019	10/4/2019	10/16/2019										
November															
December															
Senior Design 3															
January						1/30/2020									
February															
March									3/15/2020						
April												4/9/2020	4/18/2020	4/20/2020	4/20-24/2020

References

1. **STEM, Xtreme.** Inspiring The Pursuit of Careers in Manufacturing. *Xtremestem.org*. [Online] Ohio Robotics Inc. , 2019. [Cited: September 11, 2019.] xtremestem.org.
2. —. Collegiate Clash Competition Procedures. *Xtremestem.org*. [Online] January 9th, 2017. [Cited: September 12, 2019.] <https://xtremestem.org/wp-content/uploads/2017/01/Collegiate-Clash-Competition-Procedures.pdf>.
3. **Amirault, S.B.** Types of Battlebots. *S.B.A. Invent*. [Online] S.B.A. Invent, 2019. [Cited: September 12th, 2019.] <https://sbainvent.com/battlebot-design/types-of-battlebots/>.
4. **Chennu, Vinodh Reddy.** Belt Drives: Types, Advantages, Disadvantages. *ME Mechanical*. [Online] January 14, 2017. <https://me-mechanicalengineering.com/belt-drives/>.
5. **Cheslock, Markus.** *2019 UC MET Battlebot Team*. B.S. : University of Cincinnati, 2019.

Appendices

Appendix A: Parts and Sources

Drivetrain



Pololu 47:1 Metal Gearmotor 25Dx52L mm HP 12V

<https://www.pololu.com/product/3205>

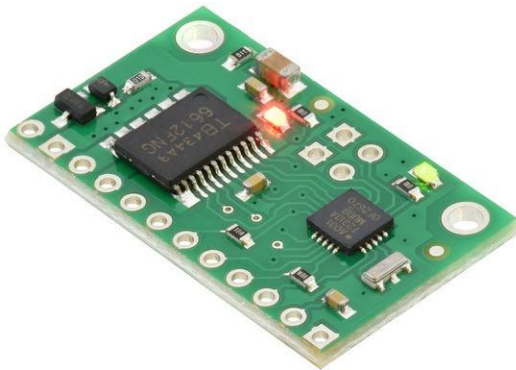

Pololu Qik 2s9v1 Dual Serial Motor Controller

<https://www.pololu.com/product/1110>



BaneBots T81 Hub, 4mm Shaft

<http://www.banebots.com/product/T81H-RM41.html>



BaneBots Wheel, 4-7/8" x 0.8", Hub Mount, 60A, Black

<http://www.banebots.com/product/T81P-496BB.html>

Weapon



Racerstar 3660 Brushless Waterproof Sensorless Motor 80A ESC For 1/8 1/10 Short Course Rally Car - 2600KV

https://www.banggood.com/Racerstar-3660-Brushless-Waterproof-Sensorless-Motor-80A-ESC-For-18-110-Short-Course-Rally-Car-p-1069993.html?ID=511866&cur_warehouse=CN

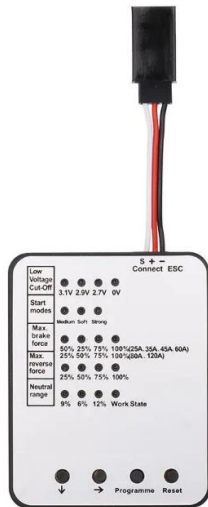

Racerstar LED Program Card for Racerstar Surpass Rocket ESC

https://usa.banggood.com/Racerstar-LED-Program-Card-For-25354560A-ESC-Motor-Set-p-1057127.html?gmcCountry=US¤cy=USD&createTmp=1&utm_source=googleshopping&utm_medium=cpc_bgcs&utm_content=frank&utm_campaign=pla-usg-all-pc&gclid=Cj0KCQjwyr0BRDcARIsAEt86IDQMq5pYJBQU5_0tST2SYvvF8JBZarmTRGY0WOz4vxZ6tzCoSyKKPkAplI6EALw_wcB&cur_warehouse=CN



2-Bolt Flange Bearing with Ball Bearing Insert and 1/2" Bore Dia.

<https://www.grainger.com/product/DAYTON-2-Bolt-Flange-Bearing-with-3FCN5>



3/4" Fixed Bore Standard V-Belt Pulley, For V-Belt Section: 4L, 5L, A, AX, B, BX

<https://www.grainger.com/product/TB-WOOD-S-3-4-Fixed-Bore-Standard-V-5RJH6>



AR620 6 Channel Sport Receiver

<https://www.spektrumrc.com/Products/Default.aspx?ProdID=SPMAR620>

Appendix B: BattleBot Survey Sample

Customer Survey

151b. Battlebot Design

The goal of this survey is to obtain customer feedback on important features to help in the conceptual design process. These questions are designed to help us determine the best styles of battlebot for competition.

Please circle or highlight your answer.

How satisfied are you with the following features on current Battlebot designs?

1=very unsatisfied 5= very satisfied

Total Investment Cost:	1	2	3	4	5
Ease of Operation:	1	2	3	4	5
Overall Efficiency:	1	2	3	4	5
Weapon Design:	1	2	3	4	5
Frame Durability:	1	2	3	4	5
Armor strength:	1	2	3	4	5
Safety:	1	2	3	4	5
Drivetrain Mechanism:	1	2	3	4	5

How important to you are the following features in a Battlebot design?

Total Investment Cost:	1	2	3	4	5
Ease of Operation:	1	2	3	4	5
Overall Efficiency:	1	2	3	4	5
Weapon Design:	1	2	3	4	5
Frame Durability:	1	2	3	4	5
Armor strength:	1	2	3	4	5
Safety:	1	2	3	4	5
Drivetrain Mechanism:	1	2	3	4	5

Are there any other features that are important to you?

Appendix C: Selection Matrices

Overall Design Concepts							
		4 Wheels with Medium Weapon		2 Wheels with Small Weapon		2 Wheels with Large Weapon	
Criteria	Relative Weight	Rating (1-3)	Weighted Rating	Rating (1-3)	Weighted Rating	Rating (1-3)	Weighted Rating
Weight	15	1	15	3	45	2	30
Cost	10	1	10	2	20	2	20
Manufacturability	15	1	15	3	45	3	45
Reliability	15	2	30	2	30	2	30
Manuverability	10	3	30	2	20	2	20
Defensive Capability	15	2	30	2	30	2	30
Offensive Capability	20	1	20	1	20	3	60
Total	100		150		210		235

Wheel Drivetrain Technology Selection

	Belt			Chain			Gearbox		
	Relative Weight	Rating (1-3)	Weighted Rating	Relative Weight	Rating (1-3)	Weighted Rating	Relative Weight	Rating (1-3)	Weighted Rating
Cost	10	3	0.71	10	1	0.24	10	2	0.48
Weight	8	2	0.38	8	1	0.19	8	3	0.57
Simplicity	6	2	0.29	6	1	0.14	6	3	0.43
Durability	5	2	0.24	5	3	0.36	5	1	0.12
Torque	7	1	0.17	7	3	0.50	7	2	0.33
Efficiency	6	1	0.14	6	2	0.29	6	3	0.43
	42		1.93	42		1.71	42		2.36

Drivetrain Motor Selection

	Brushed Motor			Brushless Motor		
	Relative Weight	Rating (1-3)	Weighted Rating	Relative Weight	Rating (1-3)	Weighted Rating
Cost	10	2	0.48	10	1	0.24
Weight	8	2	0.38	8	1	0.19
Simplicity	6	2	0.29	6	1	0.14
Durability	5	1	0.12	5	2	0.24
Torque	7	1	0.17	7	2	0.33
Efficiency	6	1	0.14	6	2	0.29
	42		1.57	42		1.43

Appendix D: 15 lb Technical Regulations for Xtreme BOTS Regional Competitions

1. General

- 1.1. All participants build and operate robots at their own risk. Combat robotics is inherently dangerous. There is no amount of regulation that can encompass all the dangers involved. Please take care to not hurt yourself or others when building, testing and competing.
- 1.2. If you have a robot or weapon design that does not fit within the categories set forth in these rules or is in some way ambiguous or borderline, please contact info@xtremebots.org. Safe innovation is always encouraged, but surprising the event staff with your brilliant exploitation of a loophole may cause your robot to be disqualified before it ever competes.
- 1.3. Compliance with all event rules is mandatory. It is expected that competitors stay within the rules and procedures of their own accord and do not require constant policing.
- 1.4. Each event has safety inspections. It is at their sole discretion that your robot is allowed to compete. As a builder you are obligated to disclose all operating principles and potential dangers to the inspection staff.
- 1.5. Cardinal Safety Rules: Failure to comply with any of the following rules could result in expulsion or worse, injury and death.
 - 1.5.1. Proper activation and deactivation of robots is critical. Robots must only be activated in the arena, testing areas, or with expressed consent of the event personnel or its safety officials.
 - 1.5.2. All robots must be able to be FULLY deactivated, which includes power to the drive and the weaponry, **within 60 seconds by a manual disconnect.** (Removable link or Main Power Switch)
 - 1.5.3. All robots not in an arena or official testing area must be raised or blocked up in a manner so that their wheels or legs cannot cause movement if the robot were turned on. Runaway bots are VERY dangerous. (We strongly suggest a custom designed block that ensures the robot will not be inadvertently dislodged from the block)
 - 1.5.4. Locking devices: Moving weapons that can cause damage or injury must have a **clearly visible** locking device in place **at all times** when not in the arena. Locking devices must be painted in neon orange or another high-visibility color. Locking devices must be clearly capable of stopping, arresting or otherwise preventing harmful motion of the weapon. C- Clamps and locking pliers are not allowed.
 - 1.5.5. Weapon locking pins **must be in place** when weapon power is applied during a robot's power-on procedure. This includes **all** powered weapons regardless of the power source or weight class.
 - 1.5.6. It is expected that all builders will follow basic safety practices during work on the robot at your pit station. Please be alert and aware of your pit neighbors and people passing by. Continued failure to follow safety directions could result in an individuals or the entire team disqualification

- for the event. (This includes and is not limited to wearing SAFETY GLASSES at ALL times while in the pit area.)
- 1.5.7. Any sharp-edged weapon must have the edge effectively covered until the bot is in the ring.
 2. Weight Classes. These events offer the 15 pound weight class only.
 3. Mobility
 - 3.1. All robots must have easily visible and controlled mobility in order to compete. Methods of mobility include:
 - 3.1.1. Rolling (wheels, tracks or the whole robot)
 - 3.1.2. Non-wheeled: non-wheeled robots have no rolling elements in contact with the floor and no continuous rolling or cam operated motion in contact with the floor, either directly or via a linkage. Motion is “continuous” if continuous operation of the drive motor(s) produces continuous motion of the robot.
 - 3.1.3. Shuffling (rotational cam operated legs)
 - 3.1.4. Ground effect air cushions (hovercrafts)
 4. Robot control requirements:
 - 4.1. Tele-operated robots must be radio controlled via 2.4GHz Spread Spectrum radio systems.
 - 4.2. Tethered control is not allowed.
 - 4.3. Radio system restrictions for this event with corresponding weight and or weapon restrictions:
 - 4.3.1. Radio systems that stop all motion in the robot (drive and weapons), when the transmitter loses power or signal, are required for all robots. This may be inherent in the robots electrical system or be part of programmed fail-safes in the radio.
 - 4.3.2. All robot radio systems must be Spektrum (preferred) or Hobby King 2.4 ghz spread spectrum radio systems. No other radio systems are allowed.
 5. Autonomous/Semi-Autonomous Robots: Any robot that moves, seeks a target, or activates weapons without human control is considered autonomous. If your robot is autonomous contact league personnel.
 - 5.1. Autonomous robots must have a clearly visible light for each autonomous subsystem that indicates whether or not it is in autonomous mode, e.g. if your robot has two autonomous weapons it should have two “autonomous mode” lights (this is separate from any power or radio indicator lights used).
 - 5.2. The autonomous functionality of a robot must have the capability of being remotely armed and disarmed. (This does not include internal sensors, drive gyros, or closed loop motor controls.)
 - 5.2.1. While disarmed, all autonomous functions must be disabled.

- 5.2.2. When activated the robot must have no autonomous functions enabled, and all autonomous functions must failsafe to off if there is loss of power or radio signal.
- 5.2.3. In case of damage to components that remotely disarm the robot, the robots autonomous functions are required to automatically disarm within one minute of the match length time after being armed.

6. Batteries and Power

- 6.1. The only permitted batteries are ones that cannot spill or spray any of their contents when damaged or inverted. This means that standard automotive and motorcycle wet cell batteries are prohibited. Examples of batteries that are permitted: gel cells, Hawkers, NiCads, NiMh, dry cells, AGM, LIon, A123 LiFe Nano Phosphate. **Lithium Polymer batteries (LiPo) are prohibited (Fire and explosion hazard exists when incorrectly charged, shorted, or punctured).** If your design uses a new type of battery, or you are not sure about it, contact info@xtremebots.org.
- 6.2. All nominal onboard maximum voltages are limited to: **24 Volts for 15# class robots** for this league. (It is understood that a charged battery's initial voltage state is above their nominal rated value)
- 6.3. All electrical power to weapons and drive systems (systems that could cause potential human bodily injury) must have a manual disconnect that can be activated within **15 seconds** without endangering the person turning it off. (E.g. No body parts in the way of weapons or pinch points.) Shut down must include a **manually** operated mechanical method of disconnecting the main battery power, such as a switch (Hella, Whyachi, etc) or removable link. Relays may be used to control power, but there must also be a mechanical disconnect. Please note that complete shut down time is specified in section 1.5.
- 6.4. All efforts must be made to protect battery terminals from a direct short and causing a battery fire.

All Robots must have a separate light per circuit that is **easily visible from the outside** of the robot and shows that its circuit's power is activated. LED's and fiber optics are good, low power options for this.

7. Pneumatics

- 7.1. All 15# robots must use Low Pressure Air systems. (LPA)
- 7.2. Pneumatic systems on board the robot must only employ nonflammable, nonreactive gases (compressed air or disposable CO2 cartridges are permissible).
- 7.3. Example diagrams of typical pneumatic systems:
 - 7.3.1. 15# class robots - CO2 based systems, see attachment below
- 7.4. Pneumatic system refilling process:
 - 7.4.1. You must have a safe way of refilling the system and determining the on board pressure.
 - 7.4.2. The maximum pressure that may be stored or used for the 15# class robot is **150 PSI** or less. The maximum total volume of pressurized gas is **8 cubic feet** at standard temperature and pressure.
 - 7.4.3. All components must be used within the specifications provided by the manufacturer or supplier. If the specifications aren't available or reliable,

then it will be up to the Safety Official to decide if the component is being used in a sufficiently safe manner.

- 7.5. You must have a safe and secure method of refilling your pneumatic system. All LPA systems must have the standard Schrader valve for refilling; all CO2 systems must use single use tanks.
- 7.6. All pneumatic components on board a robot must be securely mounted. Particular attention must be made to pressure vessel mounting and armor to ensure that if ruptured it will not escape the robot. (The terms 'pressure vessel, bottle, and source tank' are used interchangeably)
- 7.7. All pneumatic components within the robot must be rated or certified for AT LEAST the maximum pressure in that part of the system. You may be required to show rating or certification documentation on ANY component in your system.
- 7.8. All pressure vessels must be rated for at least **120%** of the pressure they are used at. (This is to give them a margin of safety if damaged during a fight.) It is not permissible to use fiber wound pressure vessels with liquefied gasses like CO2 due to extreme temperature cycling.
- 7.9. All primary pressure vessels must have an over pressure device (burst/rupture disk or over pressure 'pop off') set to no more than 130% of that pressure vessels rating. (Most commercially available bottles come with the correct burst assemblies, use of these is encouraged)
- 7.10. If regulators or compressors are used anywhere in the pneumatic system there must be an (additional) over pressure device downstream of the regulator or compressor set for no more than **130%** of the lowest rated component in that part of the pneumatic system.
- 7.11. All pneumatic systems must have a manual main shut off valve to isolate the rest of the system from the source tank. This valve must be easily accessed for robot deactivation and refilling. It must also be out of any danger areas.
- 7.12. All pneumatic systems must have a manual bleed valve downstream of the main shut off valve to depressurize the system. This bleed valve must be easily accessed for deactivation. This valve must be left OPEN whenever the robot is not in the arena to ensure the system cannot operate accidentally.
 - 7.12.1. It is **required** to be able to easily bleed all pressure in the robot before exiting the arena. (You may be required to bleed the entire system if it is believed that you have any damaged components.)
- 7.13. All pneumatic systems must have appropriate gauges scaled for maximum resolution of the pressures in that part of the system.
- 7.14. If back check valves are used anywhere in the system you must ensure that any part of the system they isolate can be bled and has an over pressure device.
8. Hydraulics
 - 8.1. Robots in the 15# class are **NOT** allowed to use hydraulics.
9. Internal Combustion Engines (ICE) and liquid fuels.
 - 9.1. Robots in the 15# class are **NOT** allowed to use ICE.
10. Rotational weapons or full body spinning robots:

- 10.1. Spinning weapons that can contact the outer arena walls during normal operation must be pre-approved by the event. (Contact with an inner arena curb, or containment wall is allowed and does not require prior permission.)
- 10.2. Spinning weapons must come to a full stop within **30 seconds** of the power being removed.
- 11. Springs and flywheels
 - 11.1. Springs used in robots will use the remaining rules in this section. Safe operation, good engineering and best practices must be used in all systems.
 - 11.2. Any large springs used for drive or weapon power must have a way of loading and actuating the spring remotely under the robots power.
 - 11.2.1. Under no circumstances must a large spring be loaded when the robot is out of the arena or testing area.
 - 11.2.2. Small springs like those used within switches or other small internal operations are exempt from this rule.
 - 11.3. Any flywheel or similar kinetic energy storing device must not be spinning or storing energy in any way unless inside the arena or testing area.
 - 11.3.1. There must be a way of generating and dissipating the energy from the device remotely under the robots power.
 - 11.4. All springs, flywheels, and similar kinetic energy storing devices must fail to a safe position on loss of radio contact or power.
- 12. Forbidden Weapons and Materials. The following weapons and materials are absolutely forbidden from use:
 - 12.1. Weapons designed to cause invisible damage to the other robot. This includes but is not limited to:
 - 12.1.1. Electrical weapons
 - 12.1.2. RF jamming equipment, etc.
 - 12.1.3. RF noise generated by an IC engine. (Please use shielding around sparking components)
 - 12.1.4. EMF fields from permanent or electro-magnets that affect another robot's electronics.
 - 12.1.5. Weapons or defenses that stop combat completely of both (or more) robots. This includes nets, tapes, strings, and other entanglement devices.
 - 12.2. Weapons that require significant cleanup, or in some way damages the arena to require repair for further matches. This includes but is not limited to:
 - 12.2.1. Liquid weapons. Additionally a bot may not have liquid that can spill out when the robot is superficially damaged.
 - 12.2.2. Foams and liquefied gasses
 - 12.2.3. Powders, sand, ball bearings and other dry chaff weapons
 - 12.3. Un-tethered Projectiles (see tethered projectile description in Special Weapons section 13.1)
 - 12.4. Heat and fire are forbidden as weapons. This includes, but is not limited to the following:

- 12.4.1. Heat or fire weapons not specifically allowed in the Special Weapons section (13.1.1)
- 12.4.2. Flammable liquids or gases
- 12.4.3. Explosives or flammable solids such as:
 - DOT Class C devices
 - Gunpowder / Cartridge Primers
 - Military Explosives, etc.
- 12.5. Light and smoke based weapons that impair the viewing of robots by an Entrant, Judge, Official or Viewer. (You are allowed to physically engulf your opponent with your robot however.) This includes, but is not limited to the following:
 - 12.5.1. Smoke weapons not specifically allowed in the Special Weapons section (13.1.1)
 - 12.5.2. Lights such as external lasers above „class I“ and bright strobe lights which may blind the opponent.
- 12.6. Hazardous or dangerous materials are forbidden from use anywhere on a robot where they may contact humans, or by way of the robot being damaged (within reason) contact humans.
- 13. Special weapon descriptions allowed at this event:
 - 13.1. Tethered Projectiles are allowed at these events, and must be no longer than 3 feet.
 - 13.1.1. Heat, Smoke and Fire are not allowed at these events.

Appendix E: Mechanical Drawings

