

# 1971 Jeep Civilian Jeep (CJ5) Modification Suspension & Brakes

Senior Design Proposal submitted to the  
Department of Mechanical and Materials Engineering  
College of Engineering and Applied Science  
University of Cincinnati

in partial fulfillment of the  
requirements for the degree of

Bachelor of Science

in Mechanical Engineering Technology

by

**Mark R. Brockert**

April 2020

Thesis Advisor:

**Professor Ahmed Elgafy, Ph.D.**

# Table of Contents

Problem Statement.....	3
Research .....	3
Background of the Problem .....	3
State of the Art.....	4
End User .....	4
Summary of Research .....	5
Quality Function Deployment.....	5
Customer Features .....	5
Engineering Characteristics .....	5
Product Objectives .....	6
House of Quality .....	7
Design Concepts .....	8
Concept/Component Selection.....	9
Disc Brake Calculations and Load Conditions.....	9
Emergency Brake Calculations and Load Conditions.....	10
Suspension Calculations and Load Conditions .....	11
Finite Element Analysis.....	12
FEA: E-Brake Bracket .....	12
FEA: Leaf Spring Suspension.....	13
Fabrication and Assembly.....	13
E-Brake Bracket Fabrication.....	13
E-Brake Bracket Assembly .....	15
Suspension and Disc Brake Assembly .....	16
Testing .....	18
Disc Brake Testing.....	18
Emergency Brake Testing.....	18
Suspension Testing .....	18
Project Management .....	19
Project Budget.....	19
Project Schedule .....	19
References: .....	20
Appendices .....	21
A1: Customer Survey.....	21
A2: E-Brake Bracket SolidWorks Drawing .....	22
A3: Initial Jeep Photos .....	23
A4: Completed Project Photos .....	24

## **Problem Statement**

Due to Jeep's utilitarian design, they are often used off- road. Off-road terrain can be very dangerous, and unfortunately older jeeps did not have the proper structure and safety features to operate feasibly in these environments. We are proposing to design, analyze, fabricate, and test various performance improvements for a 1971 Jeep CJ5 to improve the performance, safety, and structure during off-road driving. This will require a custom full tube roll cage, an improvement of the front and rear suspension, a custom and complete exhaust system, an improvement of the front and rear brakes, an addition of a custom designed emergency/parking brake system, various body and frame improvements, and various drivetrain and engine improvements.

This will be a team project and the team members consist of Melissa Rapien (M.E. 2020), Mike Rapien (M.E. 2020), and myself, Mark Brockert (M.E.T. 2020). My focus will be designing a cost effective and efficient solution to improve the performance and safety of the 1971 Jeep CJ5's suspension and braking systems. Melissa will focus on designing and building a custom exhaust system that is more free flowing, efficient, and quieter. Mike will focus on the roll cage for rollover protection.

## **Research**

### **Background of the Problem**

Jeep is an iconic American symbol known across the globe, especially among military history enthusiasts, car collectors, car restoration enthusiasts, hobbyists, and Jeep fanatics. The Jeep CJ-5 is an iconic American vehicle for so many and was hailed by many, including President Eisenhower (1), as one of the major factors in the winning of World War II. Jeep's popularity and utilitarian design has caused many owners to redesign and restore the older models to drive once again on the streets. There is also an enormous community of Jeep lovers that live and breathe to take their Jeep off-road and across the most demanding and rigorous terrains. This group of off-road fanatics and hobbyists is very large and growing, and it is a tight knit community. Most members feel a sense of camaraderie with other Jeep owners and even have a special hand wave to other Jeep motorists, similar to motorcyclists.

With the advancement of technology and Jeep, there are countless number of ways to customize your Jeep to your style and needs. There are numerous ways people utilize their Jeep, ranging from daily use transportation, mudding, trail riding, rock crawling, taking to the sand dunes, or even competing in local or national events; each requiring various performance enhancements.

Unfortunately, older models were not built with the extreme capabilities of today's standards. I will focus on two main issues that the CJ-5 was notorious for having: stiff and rigid suspension, and a poorly sealed, leaky transfer case that caused brakes to underperform by allowing oil to contact the emergency brake pads. These issues have been known and discussed by owners on online forum, earlycj5.com. The CJ-5 transfer case did not have a gasket and the stock seals were known to be inefficient (2). However, "The CJ-5 has the distinct honor of being a vehicle that was hard to kill off... equaling the longest production run of note." (3) With the arrival of the Jeep Wrangler and the mechanical and technological advancements available, the potential of Jeep's off-road abilities skyrocketed after transitioning into control arm and coil spring systems.

To fully utilize modern technology, we will be redesigning the suspension by changing the geometry, material characteristics, and the mounting design of the leaf springs. Also, we will be completely designing a custom stand-alone emergency brake system, upgrading the front brakes to discs from the standard drum brakes, and upgrading the rear drums to a newer more efficient drum brake system.

### **State of the Art**

With Jeep's popularity and aftermarket community, there is an abundance of products or solutions to improve a Jeep's performance. Most products on the market today have upgraded strength, updated geometry, and higher overall quality. However, these solutions can be very expensive and are generally marketed for extreme usage.

### **Suspension Conversion Kits**

There are many conversion kits, both Jeep specific and generic, designed to change the suspension from the standard leaf spring system to a modern shock and spring system. Coil spring setups can be very expensive and do not have the load capacity as that of leaf springs. "Leaf springs are capable of handling much higher loads with less deflection than coils." (4) Given the mounting requirements of leaf springs however, they do not provide the same amount of adjustability and customization as coil springs. Coil springs also offer more range of suspension movement however with newly designed leaf springs that are longer, wider, thinner, and softer than older designs, leaf springs can flex even more and provide a smoother and more fluid ride.

### **Retrofit Kits**

Aside from suspension conversion kits, there are also aftermarket components and kits designed from newer Jeep Wranglers that could be retrofitted but these are generally very expensive and time consuming. For example, rocky-road.com offers kits for many different models of Jeeps and their solutions for the 1971 CJ-5 range from \$2857 - \$3387 (5). These kits would require adding control arms and many additional parts with the newer systems that may not be necessary for non-extreme use.

### **Brakes**

Brake technology has not changed drastically but it has been improved upon since 1971. By upgrading to modern and more efficient drum and disc brakes, the braking power will be improved tremendously. However, there are no readily available emergency brake kits besides the standard transfer case mounted, E-brake kit from Kaiser Willys Auto Supply LLC. This kit cost \$399.99 (6) and will not solve the underlying problem of a leaking transfer case that has since been redesigned and now includes gaskets and proper seals. Consequently, we propose to design a standalone E-brake system.

### **End User**

The end user of this project will most likely be an owner of any older model Jeep that would like to improve the performance and safety of their Jeep for off-road use. Many owners may not benefit from this as it designed for hobbyists and off-road enthusiasts. The end user is looking

for a cost effective and efficient solution that will allow their Jeep to travel safely in an off-road environment while remaining road legal. There are many existing solutions, but most are typically very expensive.

### **Summary of Research**

My solution should be cost effective and efficient in terms of performance and durability. We do not need top of the line performance but to maintain a healthy balance of cost, efficiency, and safety in order to safely operate the Jeep in low to medium risk trail riding. We will not be doing extreme rock crawling so complete coil conversion is not necessary however, by redesigning the leaf spring geometry, we will need to redesign mounting brackets and frame supports. We will also need to design a cost effective and standalone E-brake system to eliminate the possibility of oil contaminating the brake pads.

## **Quality Function Deployment**

### **Customer Features**

Using the above research and the survey responses, the following customer features were ranked in order of importance based on the weight achieved from the survey results. See appendix for survey.

1. Safety (4.8)
2. Durability (4.4)
3. Maneuverability (4.2)
4. Cost (2.6)
5. Easy Installation (2.1)
6. Fuel Efficiency (1.2)

### **Engineering Characteristics**

Using the Material Selection/Part Quality (25%): Material selection for machined and fabricated parts and part quality for purchased parts will need to be considered to improve durability and overall design quality

Suspension Flexibility/Ductility (13%): Ability of the suspension to flex (or not flex) when necessary under applicable circumstances. There will be some specific range of motion that will have to be calculated as efficient for off-road use and this range will need to be maintained throughout design changes.

Weight (8%): The weight will ideally be minimized to improve engine performance and braking power

Braking Force (14%): Braking power will ideally be maximized to improve the time required to come to complete stop but also to hold the vehicle in an unnatural position as will likely be needed during off-road use.

Installation Time (5%): The installation and design complexity will ideally be minimized while maintaining efficiency.

Additional E-Brake (13%): Assist with braking during off-road use if standard brakes are less efficient due to environment (mud, sand, etc.)

Total Cost (5%): The cost will ideally be minimized

Stability (8%): Weight Distribution and stability of the vehicle will need to be maintained during street and off-road use under normal circumstances.

Turning Radius (9%): There will be some specific range of motion that will have to be calculated as efficient for off-road use and this range will need to be maintained throughout design changes

## **Product Objectives**

1. Safety (27%)
  - a. Materials and components will be selected/designed to withstand the mechanical stresses during operation
  - b. Braking force/capacity will be maximized
  - c. Additional standalone E-brake system will be designed and installed
2. Durability (24%)
  - a. Materials and components will be selected/designed to withstand the mechanical stresses during operation
3. Maneuverability (23%)
  - a. Weight will be minimized
  - b. Materials and components will be selected/designed to withstand the mechanical stresses during operation
4. Cost (14%)
  - a. Design changes will follow proposed budget as closely as possible
5. Easy Installation (12%)
  - a. Design changes will be cost effective and attempt to design solution as functional as possible without overdesigning.

# House of Quality

QFD: House of Quality  
 Project: 1971 Jeep CJ-5 Redesign  
 Revision: 2  
 Date: 10/3/2019

Mark Brockert

Correlations	
Positive	+
Negative	-
No Correlation	

Relationships	
Strong	●
Moderate	○
Weak	▽

Direction of Improvement	
Maximize	▲
Target	◇
Minimize	▼

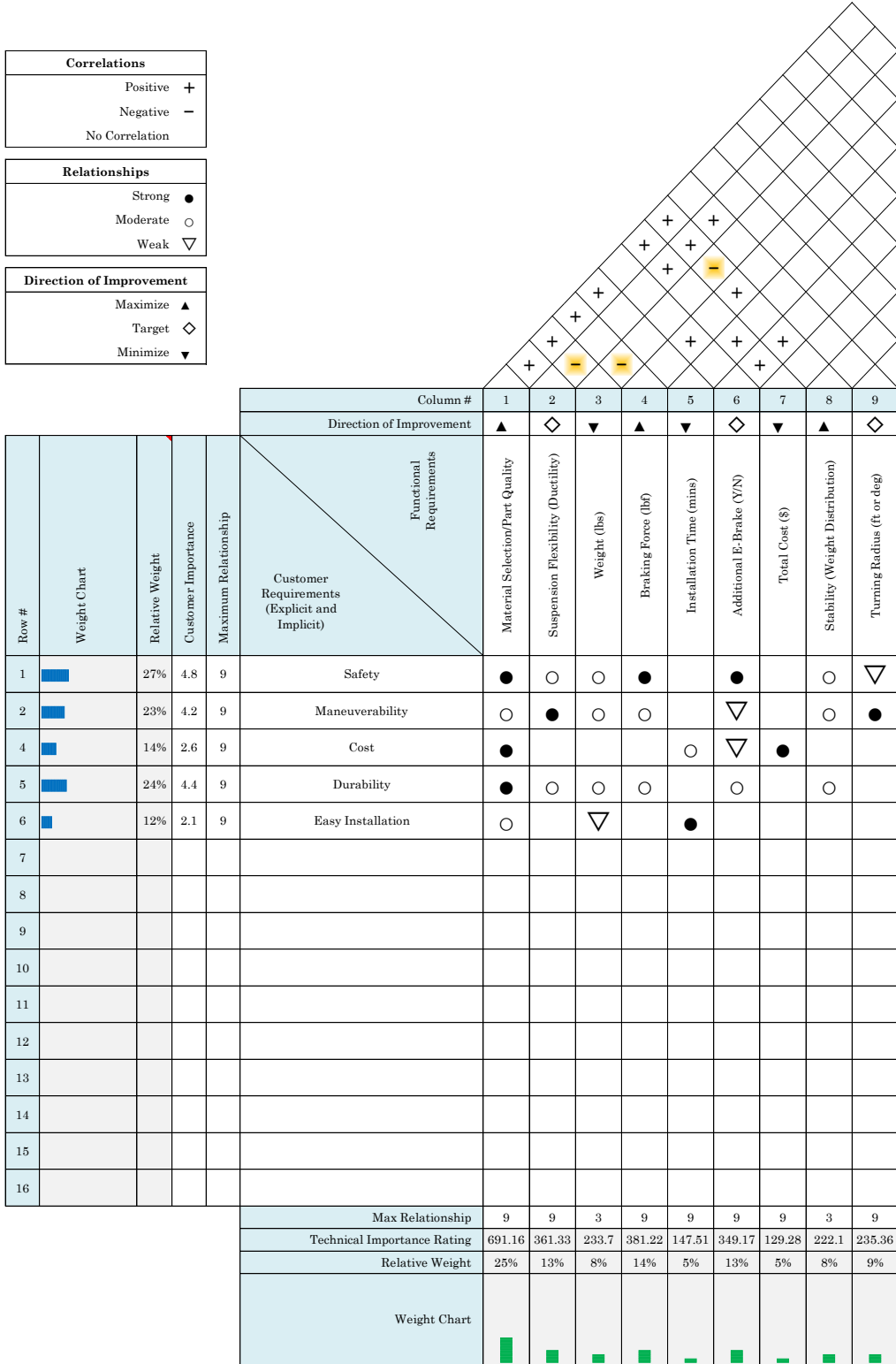

Figure 1: House of Quality

## Design Concepts

### E-Brake Concept 1

A brake rotor and caliber can be mounted to the transfer case on the rear axle shaft between the transfer case yoke. An e-brake system can be accomplished with an e-brake pedal and cable that presses brake pads on the rotor that will stop the rear axle driveshaft.

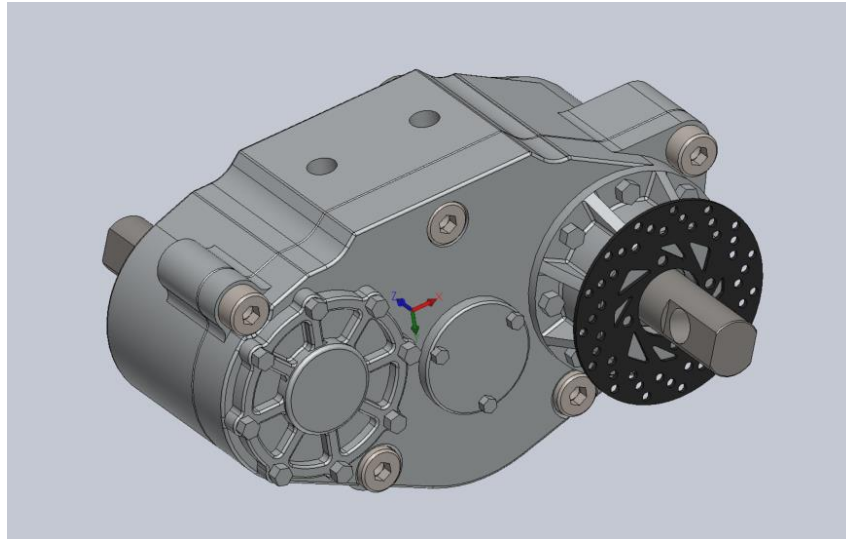

Figure 2: E-Brake concept 1 3D screen capture of transfer case and rotor

### Suspension Concept 1

Longer leaf springs that will allow for increased flexibility but will require adjustment of mounting locations. This concept is simple and cheap.

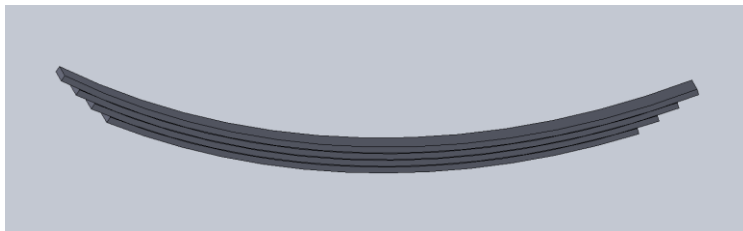

Figure 3: Altered size leaf spring concept 1

### Suspension Concept 2

Longer, wider, thinner, and softer leaf springs allowing for increased flexibility and a smoother ride but because they are wider, will require newly designed mounting brackets (not yet modeled). This concept will provide better performance but will require additional testing and calculation to determine appropriate width, material selection and mounting location.



Figure 4: Altered size leaf spring concept 2

## Concept/Component Selection

### Disc Brake Calculations and Load Conditions

The brake component selection was reverse engineered to ensure performance and safety standards set by the National Association of Transportation. These specifications required a vehicle traveling at 30mph to stop within 45ft and 4 seconds. The calculations using the selected braking components can be seen below:

Overall weight + driver  $\cong$  3000 lbs.

Vehicle speed  $\cong$  30mph = 44ft/s

$$\text{Kinetic Energy} = \frac{1}{2}mv^2 = \frac{1}{2} \left( \frac{3000\text{lb}}{32.2\text{ft/s}^2} \right) \left( \frac{44\text{ft}}{\text{s}} \right)^2 = 90186.34 \text{ ft. lb.}$$

$$\text{Required Stopping Force} = \frac{\text{KE}}{\text{SD}} = \frac{90186.34 \text{ ft. lb.}}{45\text{ft}} = 2004.14 \text{ lbf}$$

$$\text{Minimum Stopping Force per tire: } \frac{2004.14\text{lb}}{4 \text{ tires}} = 501.04 \text{ lbf}$$

Estimated Driver force on brake pedal: 70 lbf

Master Cylinder Diameter = 1in

Diameter of Rotor = 11.75in

Diameter of Tire = 33in

Caliper OD = 2.9125in

Coefficient of Friction = 0.4

$$\text{Pedal Ratio} = \frac{24.8\text{in}}{4\text{in}} = 6.2$$

Mechanical Brake Pedal Output Force: Pedal Ratio \* Pedal Force

$$F_{\text{BP}} = 6.2(70\text{lb}) = 437.50\text{lb}$$

Master Cylinder Hydraulic Pressure:  $F_{\text{BP}}/\text{Effective Area}$

$$P_{\text{MC}} = 437.50\text{lb} / \left( \frac{\pi(1\text{in})^2}{4} \right) = 557.04 \text{ psi}$$

Caliper Force:  $P_{\text{MC}} * \text{Caliper Area}$

$$F_{\text{Cal}} = 557.04\text{psi} \left( \frac{\pi(2.9125\text{in})^2}{4} \right) = 3711.16 \text{ lb.}$$

Clamp Force:  $2 * F_{\text{Cal}} = 2(3711.16\text{lb}) = 7422.32 \text{ lb.}$

Friction Force:  $\mu_{\text{Rotor}} * F_{\text{Clamp}} = 0.4(7422.32\text{lb}) = 2968.93 \text{ lb.}$

Torque:  $F_f * \text{Rotor Radius} = 2968.93\text{lb} \left( \frac{11.75}{2} \text{in} \right) = 17442.46 \text{ lb. in}$

Stopping Force per tire:  $\frac{T}{\text{Tire Radius}} = \frac{17442.46\text{lb in}}{\frac{33}{2}\text{in}} = 1057.12 \text{ lb.}$

$$\text{Disc Brake FoS} = \frac{1057.12\text{lb}}{501.04\text{lb}} = 2.11$$

## Emergency Brake Calculations and Load Conditions

The brake component selection was reverse engineered to ensure performance and safety standards set by the National Association of Transportation. These specifications required a vehicle must remain stationary on an incline of at least 20 degrees after the parking brake is engaged. The calculations using the selected braking components can be seen below:

$$\theta = 20^\circ$$

Dry Road Conditions,  $\mu = 0.7$

Wet Road Conditions,  $\mu = 0.4$

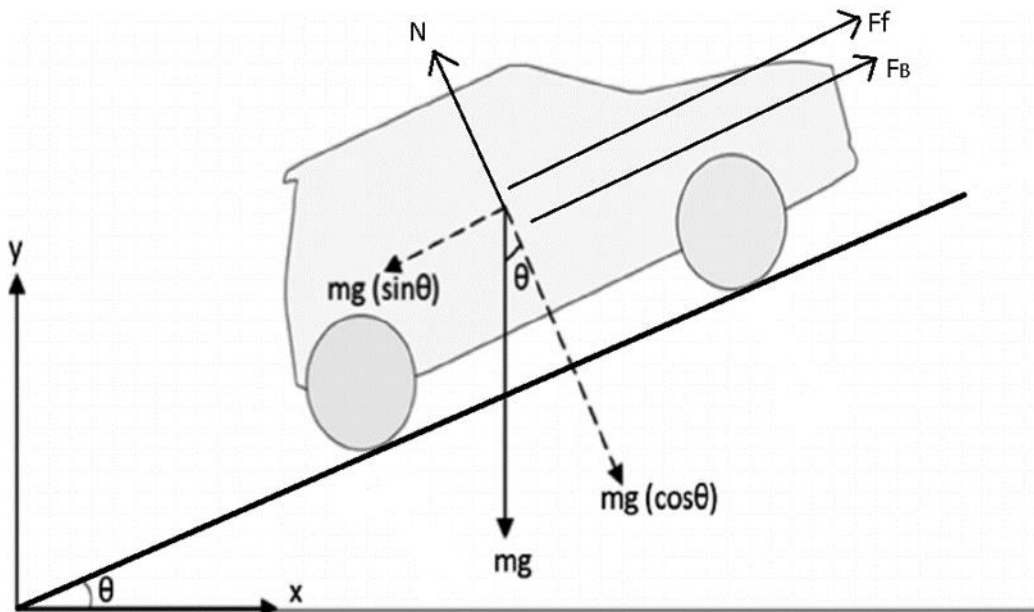

Figure 5: E-Brake Calc. Free Body Diagram

$$\sum F_y = 0 = N - mg(\cos\theta)$$

$$N = mg(\cos\theta)$$

$$F_f = \mu N = mg(\cos\theta)\mu$$

$$\sum F_x = 0 = F_B + F_f - mg(\sin\theta)$$

$$F_B = mg(\sin\theta) - mg(\cos\theta)\mu$$

$$\text{Dry } F_B = 3000\sin 20 - 3000\cos 20(0.7) = 1881.9\text{lb}$$

$$\text{Wet } F_B = 3000\sin 20 - 3000\cos 20(0.4) = 2249.2\text{lb}$$

Parking Brake Pedal Ratio: 6.2

Parking Brake Pedal Force: 140 lb.

Master Cylinder Diameter = 1in

Caliper OD = 2.9125in

Parking Brake Pedal Output Force: Pedal Ratio \* Pedal Force

$$F_{BP} = 6.2(140\text{lb}) = 868\text{lb}$$

Master Cylinder Hydraulic Pressure:  $F_{BP}/\text{Effective Area}$

$$P_{MC} = 868\text{lb} / \left( \frac{\pi(1\text{in})^2}{4} \right) = 1105.17 \text{ psi}$$

Caliper Force:  $P_{MC} * \text{Caliper Area}$

$$F_{Cal} = 1105.17\text{psi} \left( \frac{\pi(2.9125\text{in})^2}{4} \right) = 7362.95 \text{ lb.}$$

Clamp Force:  $2 * F_{Cal} = 2(7362.95\text{lb}) = 14725.89 \text{ lb.}$

Friction Force:  $\mu_{Rotor} * F_{Clamp} = 0.4(14725.89\text{lb}) = 5890.36 \text{ lb.}$

$$\text{Dry Road FoS} = \frac{5890.36\text{lb}}{1881.9\text{lb}} = 3.13$$

$$\text{Wet Road FoS} = \frac{5890.36\text{lb}}{2249.2\text{lb}} = 2.62$$

### Suspension Calculations and Load Conditions

The suspension component selection was reverse engineered to ensure performance and safety standards set by the project budget, scope, and the desired function of the Jeep. A leaf spring design is ideal due to the simplicity, affordability, and performance capabilities. Although a spring coil system could provide greater performance capabilities, the budget and desired performance allow for a leaf spring design to provide the necessary output.

Overall weight + driver  $\cong 3000 \text{ lbs.}$

Each leaf spring supports  $\frac{1}{4}$  of total weight

AISI 5160 Alloy Spring Steel:

- Yield Strength,  $S_y = 39,900 \text{ psi}$
- Ultimate Strength,  $S_u = 105,000 \text{ psi}$

$$\sigma_{\max} = \frac{3FL}{Nbh^2} = \frac{3\left(\frac{3000}{4}\text{lb.}\right)22\text{in}}{5(2.5\text{in})(1.25\text{in})^2} = 2534.4 \text{ psi}$$

F : applied force                      L : characteristic length

N : number of layers/leafs      b : leaf width                      h : total thickness

$$\text{Static } \sigma_d = \frac{S_y}{2} = \frac{39,900}{2} = 19950 \text{ psi}$$

$$\text{Static FoS} = \frac{19950}{2534.4} = 7.87$$

$$\text{Repeated } \sigma_d = \frac{S_u}{8} = \frac{105,000}{8} = 13125 \text{ psi}$$

$$\text{Repeated FoS} = \frac{13125}{2534.4} = 5.18$$

$$\text{Impact } \sigma_d = \frac{S_u}{12} = \frac{105,000}{12} = 8750 \text{ psi}$$

$$\text{Impact FoS} = \frac{8750}{2534.4} = 3.45$$

# Finite Element Analysis

## FEA: E-Brake Bracket

The finite element analysis performed with SolidWorks Simulation assumed the emergency brake bracket will be made from a 6061 Alloy and be subjected to 500 lbs. of tangential force from the rotor and caliper even though it will likely never see this amount of force in normal use. The simulation yielded a max stress of 2.753e+03 psi in the neck of the bracket with a safety factor of about 2.9

Max Stress: 2.753e+03 psi

$$FoS = \frac{7.999}{2.753} = 2.91$$

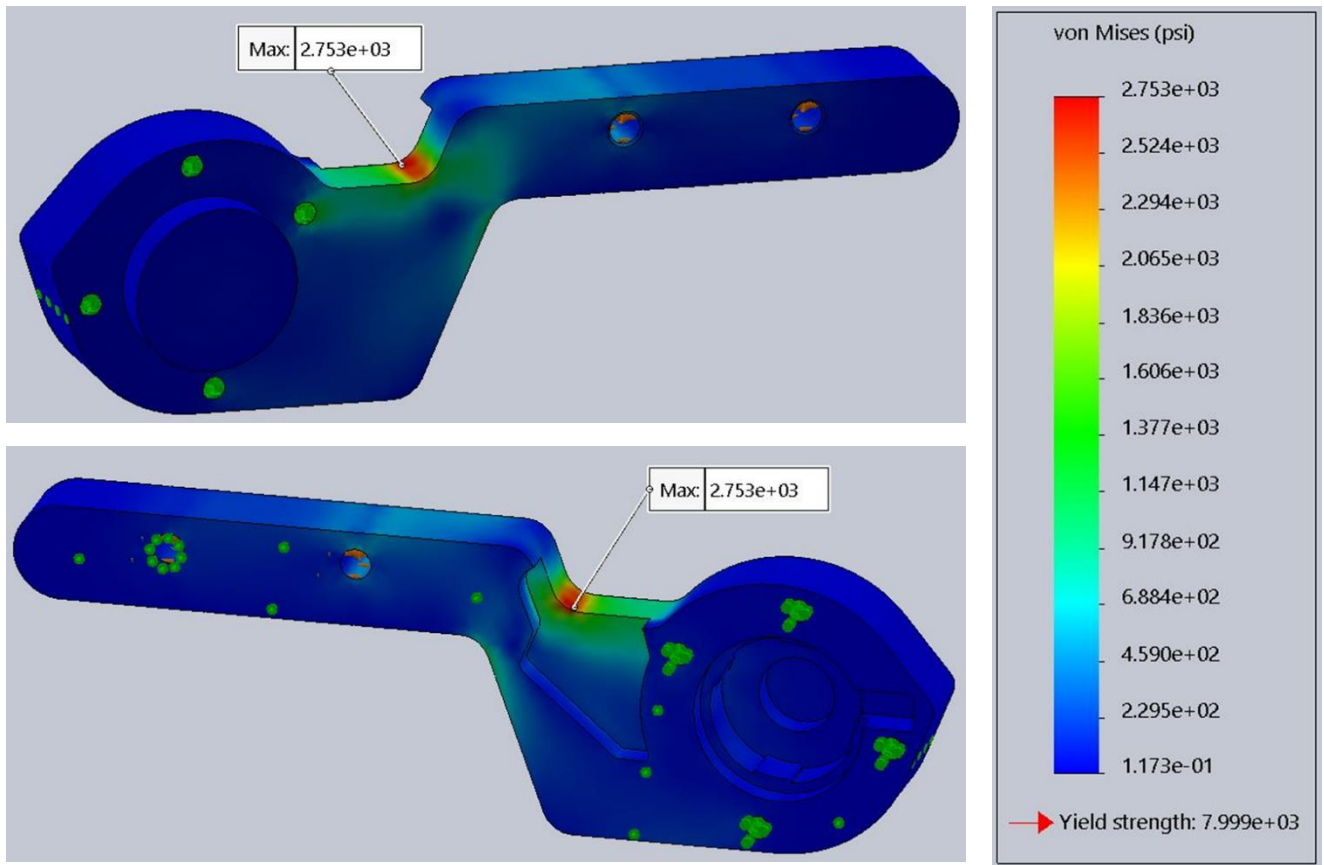

Figure 6: E-Brake Bracket FEA Simulation Results

## FEA: Leaf Spring Suspension

The finite element analysis performed with SolidWorks Simulation assumed each leaf spring supports a quarter of the total weight of the Jeep ( $3000\text{lbs.} \cdot \frac{1}{4}$ ) = 750lbs. The simulation is an impact or drop study and yielded a max stress of  $2.254\text{e}+04$  psi in the bottom plate of the main leaf with a safety factor of about 1.77.

Max Stress:  $2.254\text{e}+04$  psi

$$\text{FoS} = \frac{3.99}{2.254} = 1.77$$

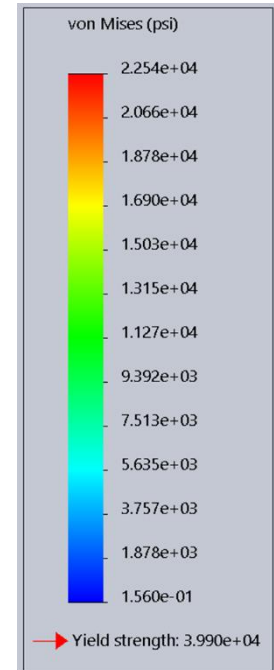
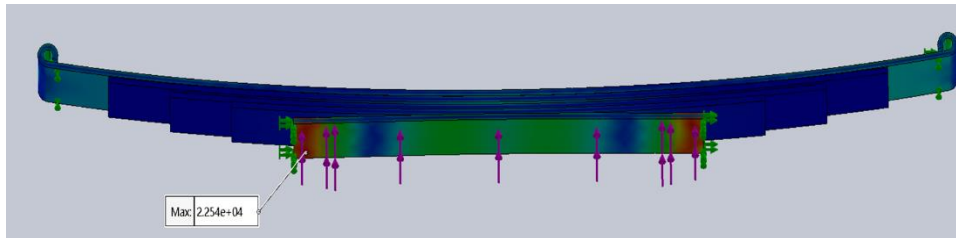

Figure 7: Leaf Spring FEA Simulation Results

## Fabrication and Assembly

### E-Brake Bracket Fabrication

For the e-brake system, the bracket is designed to support the caliper and replace the overdrive cap. The bracket mounts to the overdrive and holds the caliper over the rotor attached to the rear axle shaft. The bracket will be CNC milled and drilled at the 1819 innovation hub. The fabrication process started with a 3D CAD model and creating a CAM setup in Autodesk Fusion 360. Using the CAM setup created, the aluminum stock seen below in Figure 8 was then CNC machined to form the designed part.

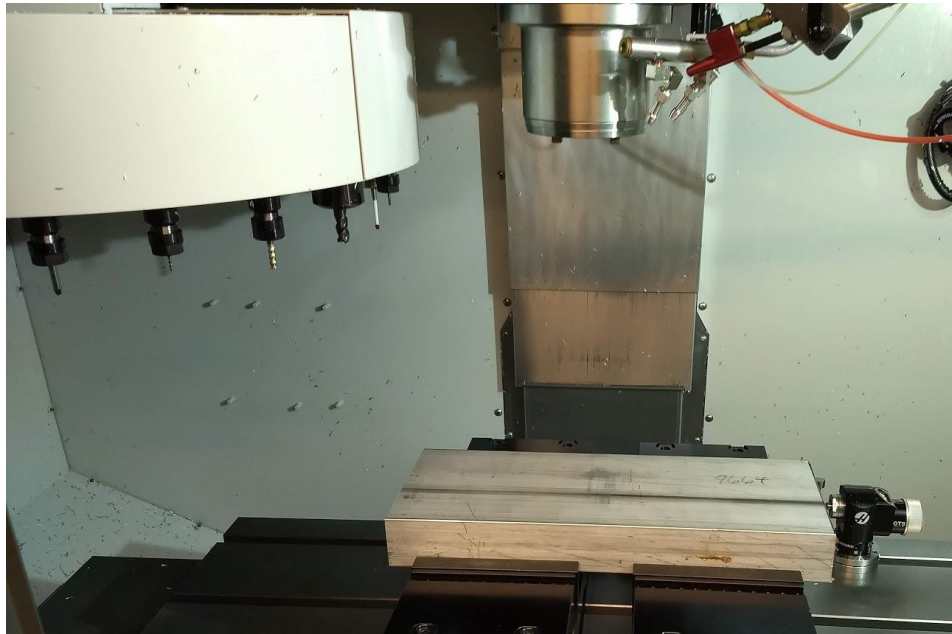

Figure 8: Part stock in HAAS CNC Machine

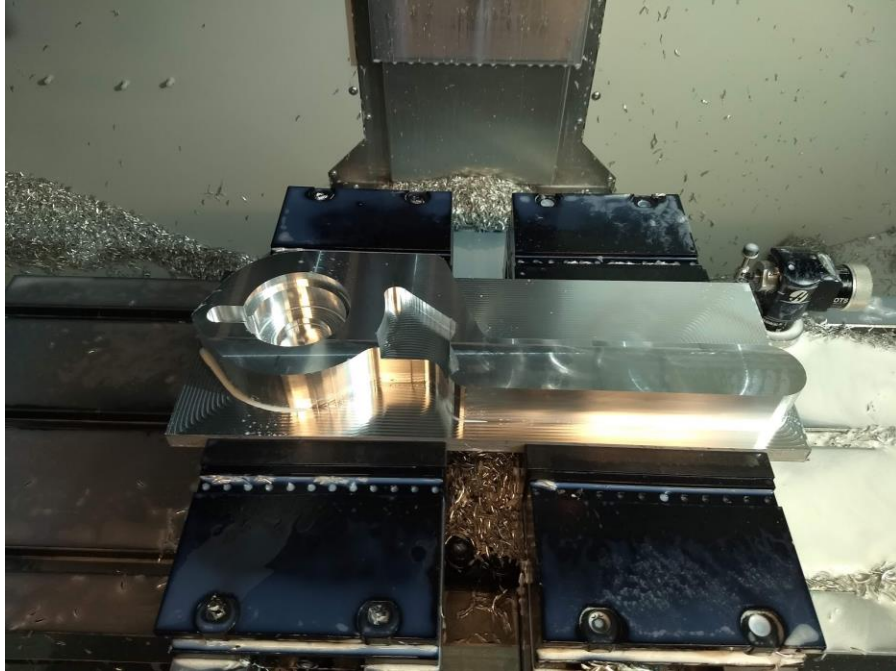

Figure 9: Bottom contour of e-brake bracket



Figure 10: Finished part

## E-Brake Bracket Assembly

After receiving the final finished part, the assembly process could begin. The first step was to remove the original overdrive cap and then mount the bracket in place of that cap. Then the bracket was mounted to the red e-brake caliper seen below in Figure 11.

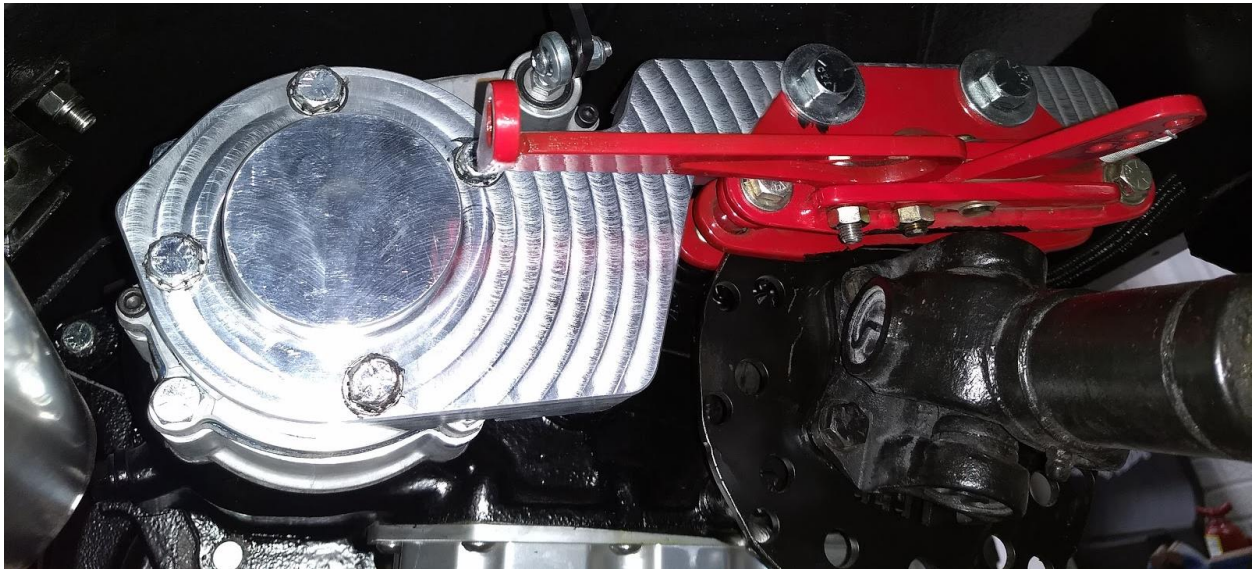
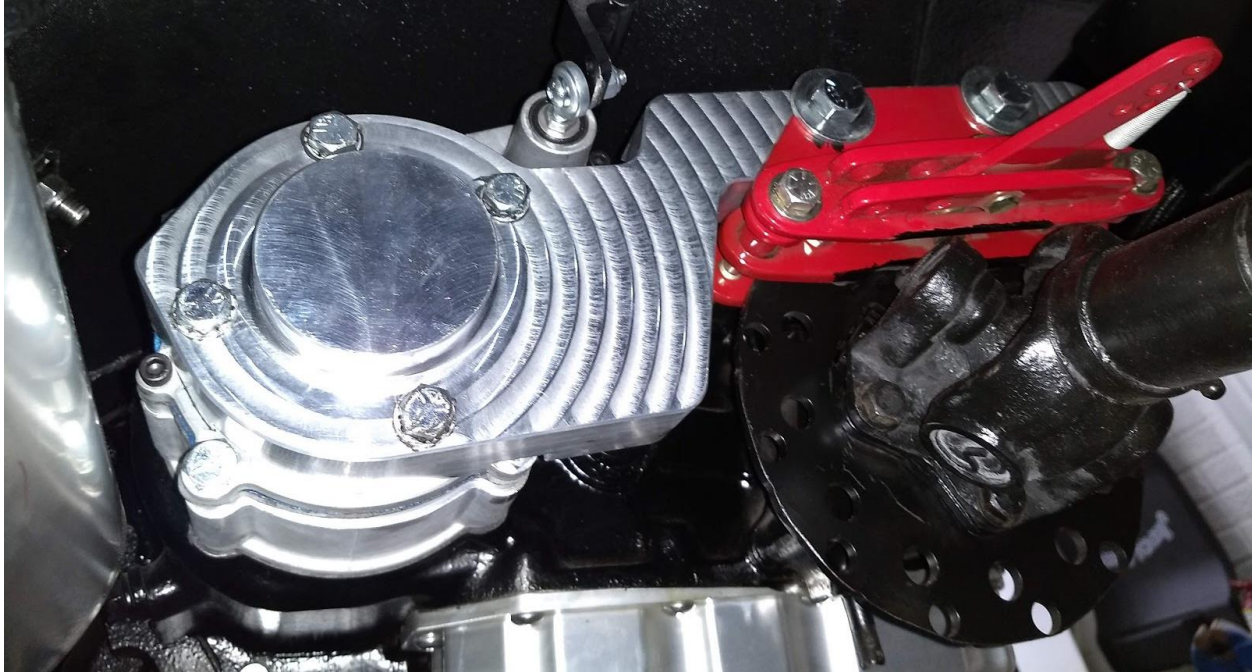

Figure 11: Finished Assembly mounted to overdrive and e-brake caliper

## Suspension and Disc Brake Assembly

The assembly of the suspension and disc brakes were simply removing the original components and replacing them with the newly selected parts. The only modification needed for these components was the mounting bracket location for the leaf springs. Because the new leaf springs are longer than the original springs, the mounting locations in the center of the Jeep needed to be moved down the frame.



Figure 12: Inside mount for front driver side leaf spring



Figure 13: Axle mount for leaf spring



Figure 14: End mount for front driver side leaf spring

# Testing

## Disc Brake Testing

For testing, standards from the National Association of Transportation and the US Department of Transportation were used. The standards require that a vehicle moving at 30mph must stop within 45ft and 4 seconds. In an open parking lot, we placed markers 45 feet apart and recorded the time to stop (from the passenger seat) from passing the first marker to coming to a complete stop. We then measured the distance from the second marker to determine the stopping distance. There are many variables that contributed to our data variability including reaction time (for both driver and stopwatch user) and speed variability. Our control speed was 30 mph, however, due to analog gauges, this is approximate.

Trial	Time to Stop (seconds)	Stopping Distance (feet)
1	3.81	42.80
2	3.95	43.80
3	4.21	45.88
4	3.85	43.60
5	4.77	46.45
6	3.79	41.41
7	3.84	43.28
8	3.98	44.00
9	3.84	42.95
10	4.15	45.30
<b>Average</b>	<b>4.019</b>	<b>43.947</b>

Table 1: Stopping Distance and Time

As seen in the Table 1 above, the stopping distance met the specification however, the stopping time had enough outliers to push the average above the required specification. Given the variables and the fact that the newer break lines still may have air in the system, this data is acceptable for our purposes.

## Emergency Brake Testing

For emergency brake testing, the standards from the National Association of Transportation and the US Department of Transportation require the vehicle must remain stationary on an incline of at least 20 degrees after the parking brake is engaged. For our purposes, we parked the Jeep on numerous inclines with varying degrees and recorded no slippage or movement allowed from the brake system.

## Suspension Testing

For the suspension, we planned to measure the flexibility by determining the Ramp Travel Index score. The RTI score indicates the amount of axle articulation possible. Using a 20-degree ramp, the vehicle drives one tire up the ramp until the point when one of the other tires starts to lift off the ground. The score is then calculated by measuring the distance traveled up the ramp divided by the vehicle's wheelbase, and then multiplying by 1000. An RTI score of 1000 means the vehicle can travel exactly the distance of its wheelbase. Most stock SUVs score between 400 and 600 so that will be the benchmark. Unfortunately, due to COVID-19 we were unable to find a suitable ramp to perform this test.

# Project Management

## Project Budget

1971 Jeep CJ-5 Budget			
Item	Projected Cost	Actual Cost	+/-
Disc Brakes	\$400.00	\$347.23	\$52.77
E-Brake Rotor/Caliper	\$300.00	\$275.67	\$24.33
CNC Consultation (\$24/hr)	\$48.00	\$0.00	\$48.00
CNC Material	\$500.00	\$118.27	\$381.73
CNC Machine Time (\$24/hr)	\$120.00	\$168.00	-\$48.00
Omix Suspension 5 Leaf Spring	\$600.00	\$516.80	\$83.20
Suspension Hardware	\$600.00	\$656.37	-\$56.37
Exhaust Piping Material	\$300.00	\$285.45	\$14.55
Roll Cage Steel	\$460.00	\$335.19	\$124.81
Tube Bender	\$1,000.00	\$964.30	\$35.70
<b>Total</b>	<b>\$4,328.00</b>	<b>\$3,667.28</b>	<b>\$660.72</b>

Table 2: Project Budget

## Project Schedule

Milestone	Start Date	Proposed Completion Date	Actual Completion Date	+/-
Senior Design 1971 Jeep CJ-5 Redesign	8/26/2019	4/1/2020	4/17/2020	-16
Submit Advisor Agreement	8/26/2019	9/6/2019	9/4/2019	2
Submit Research	8/26/2019	9/13/2019	9/13/2019	0
Complete QFD	9/13/2019	9/27/2019	9/26/2019	1
Final Proposal	8/26/2019	10/4/2019	10/4/2019	0
Concept Designs	10/7/2019	10/21/2019	10/21/2019	0
Calculations	10/14/2019	10/28/2019	10/28/2019	0
Concept Selection	10/28/2019	11/1/2019	11/1/2019	0
3D Modeling	11/4/2019	11/25/2019	12/29/2019	-34
Material/Part Selection	11/25/2019	1/26/2020	1/12/2020	14
Manufacture	1/28/2020	2/17/2020	3/13/2020	-25
Build	12/2/2019	3/9/2020	4/3/2020	-25
Test	3/9/2020	3/27/2020	4/11/2020	-15
Design Report/Presentations	10/4/2019	3/27/2020	4/17/2020	-21
Tech Expo	4/9/2020	4/9/2020	-	-
Final Presentation	4/22/2020	4/22/2020	4/17/2020	5

Table 3: Project Schedule

## References:

1. Tellem, Tori. History of the CJ-5 - Jeep Autopsy: CJ-5. *Fourwheeler Network*. [Online] Motor Trend Group, LLC., March 11, 2008. [Cited: September 10, 2019.] <http://www.fourwheeler.com/project-vehicles/154-0707-history-of-jeep-cj5-jeep-autopsy/>.
2. earlycj5.com. *Transfer case Leak?* July 20, 2006.
3. Jeep CJ. *Wikipedia*. [Online] Wikipedia Foundation, Inc., August 11, 2019. [Cited: September 10, 2019.] [https://en.wikipedia.org/wiki/Jeep\\_CJ](https://en.wikipedia.org/wiki/Jeep_CJ).
4. Leaf Springs Vs. Coil Springs: Which Suspension System Is Better? *Mack Springs*. [Online] Mack Springs, February 15, 2017. [Cited: September 12, 2019.] <https://www.macksprings.com/leaf-springs-vs-coil-springs-which-suspension-system-is-better/>.
5. CJ to YJ Spring Conversion Kit for 1955-75. *Rocky-Road*. [Online] [Cited: September 26, 2019.] <https://www.rocky-road.com/yj-spring-conversion-55-75.html>.
6. E-Brake Kit. *Kaiser Willys*. [Online] Kaiser Willys Auto Supply LLC. [Cited: September 12, 2019.] <https://www.kaiserwillys.com/category/brakes/emergency-brakes/complete-nos-emergency-brake-backing-plate-assembly-kit-fits-42-71-jeep-willys-7689>.
7. The Pros and Cons of Drum Brakes. *Haynes*. [Online] [Cited: September 10, 2019.] <https://haynes.com/en-us/tips-tutorials/pros-and-cons-cars-drum-brakes>.
8. Brauer, Karl. Brakes: Drum vs. Disc. *Edmunds*. [Online] Edmunds.com, Inc., May 12, 2009. [Cited: September 10, 2019.] <https://www.edmunds.com/car-technology/brakes-drum-vs-disc.html>.
9. Transfer Case. *Wikipedia*. [Online] Wikipedia Foundation, Inc., March 18, 2018. [Cited: September 10, 2019.] [https://en.wikipedia.org/wiki/Transfer\\_case](https://en.wikipedia.org/wiki/Transfer_case).
10. Jeep Wrangler (YJ). *Wikipedia*. [Online] Wikipedia Foundation, Inc., August 25, 2019. [Cited: September 10, 2019.] [https://en.wikipedia.org/wiki/Jeep\\_Wrangler\\_\(YJ\)](https://en.wikipedia.org/wiki/Jeep_Wrangler_(YJ)).
11. Jeep Wrangler. *Wikipedia*. [Online] Wikipedia Foundation, Inc., August 28, 2019. [Cited: September 10, 2019.] [https://en.wikipedia.org/wiki/Jeep\\_Wrangler](https://en.wikipedia.org/wiki/Jeep_Wrangler).
12. Rock Crawling. *Wikipedia*. [Online] Wikipedia Foundation, Inc., September 5, 2019. [Cited: September 10, 2019.] [https://en.wikipedia.org/wiki/Rock\\_crawling](https://en.wikipedia.org/wiki/Rock_crawling).
13. Vehicle Profiles: Jeep Willys. *The Journal Classic Cars*. [Online] The Collector Car Network, Inc., July 1, 2008. [Cited: September 10, 2019.] <https://journal.classiccars.com/2008/07/01/the-jeep/>.
14. Jeep. *Wikipedia*. [Online] Wikipedia Foundation, Inc., August 11, 2019. [Cited: September 10, 2019.] <https://en.wikipedia.org/wiki/Jeep>.
15. Davin, Shawn. *1970-1981 Camaro Suspension Redesign*. s.l. : University of Cincinnati, 2018. Baccalaureate Thesis.
16. Byler, Blake. *Vette-Kart Suspension*. s.l. : University of Cincinnati, 2019. Baccalaureate Thesis.

# Appendices

## A1: Customer Survey

### Jeep CJ-5 (Suspension and Brakes)

This survey results will be used in a University of Cincinnati Mechanical Engineering senior design project to prioritize various features to maximize customer satisfaction and help gain a better understanding of necessary design changes needed to improve a Jeep CJ-5's performance and safety.

**Please circle ALL answers that apply to you:**

- 1) What is the main use of your Jeep?
  - a) Street use (daily driving)
  - b) Casual Street use (non-daily driver)
  - c) Rock Crawling
  - d) Mudding
  - e) Sand Dunes
  - f) Trail Riding

- 2) How important is each feature to you? 1= Low Importance 5 = High Importance

Safety	1	2	3	4	5	N/A
Maneuverability	1	2	3	4	5	N/A
Fuel Efficiency	1	2	3	4	5	N/A
Cost	1	2	3	4	5	N/A
Durability	1	2	3	4	5	N/A
Easy Installation	1	2	3	4	5	N/A

- 3) How much are you willing to spend on a suspension upgrade?
  - a) \$0-300
  - b) \$300-500
  - c) \$500-750
  - d) \$750+
- 4) Would a custom E-brake solution benefit you?
  - a) Yes
  - b) No

## A2: E-Brake Bracket SolidWorks Drawing

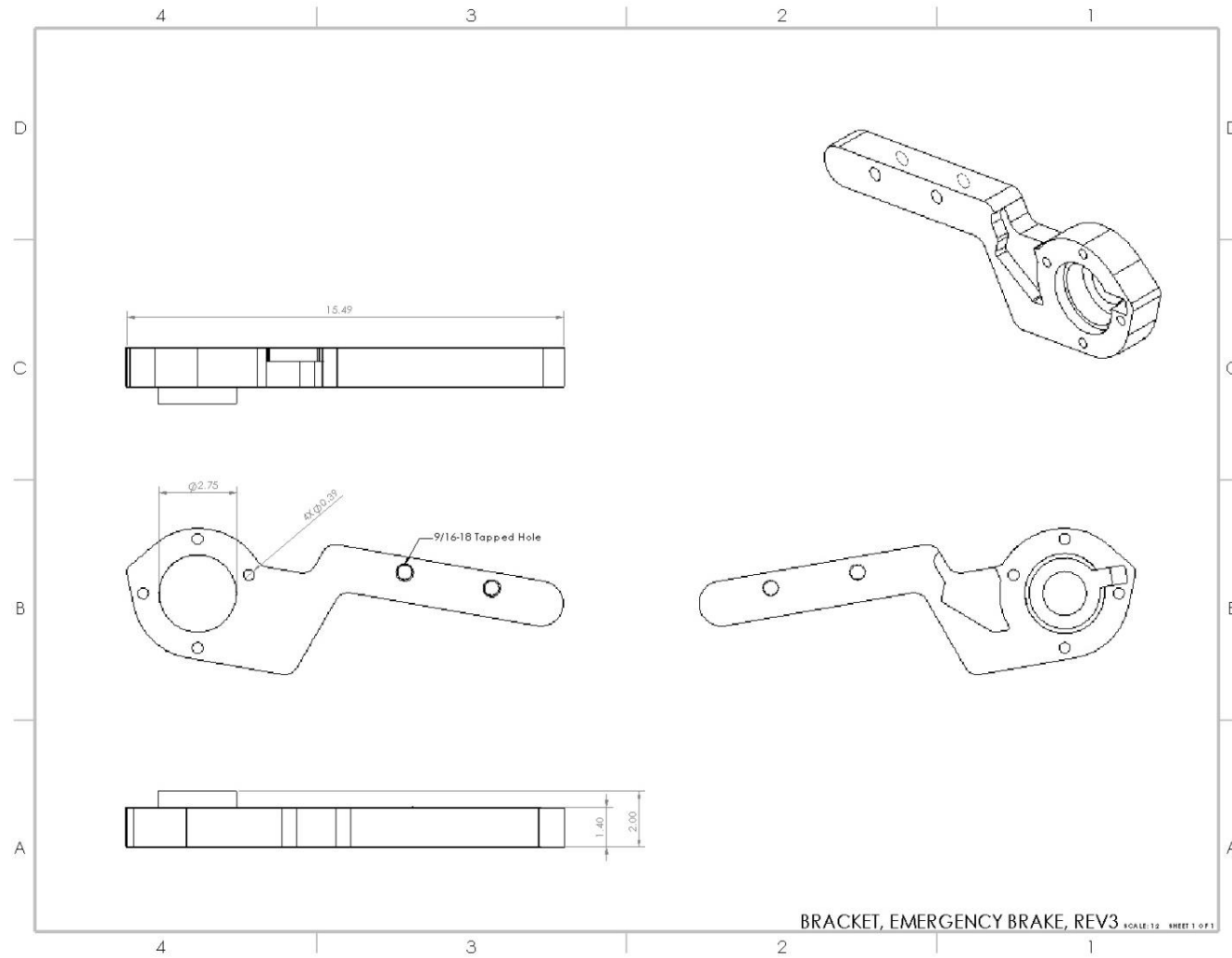

**A3: Initial Jeep Photos**



## A4: Completed Project Photos

AFTER

